

catalogo generale

**015**

**antoniolupi**

bagnarsi ad arte\_bathing with art



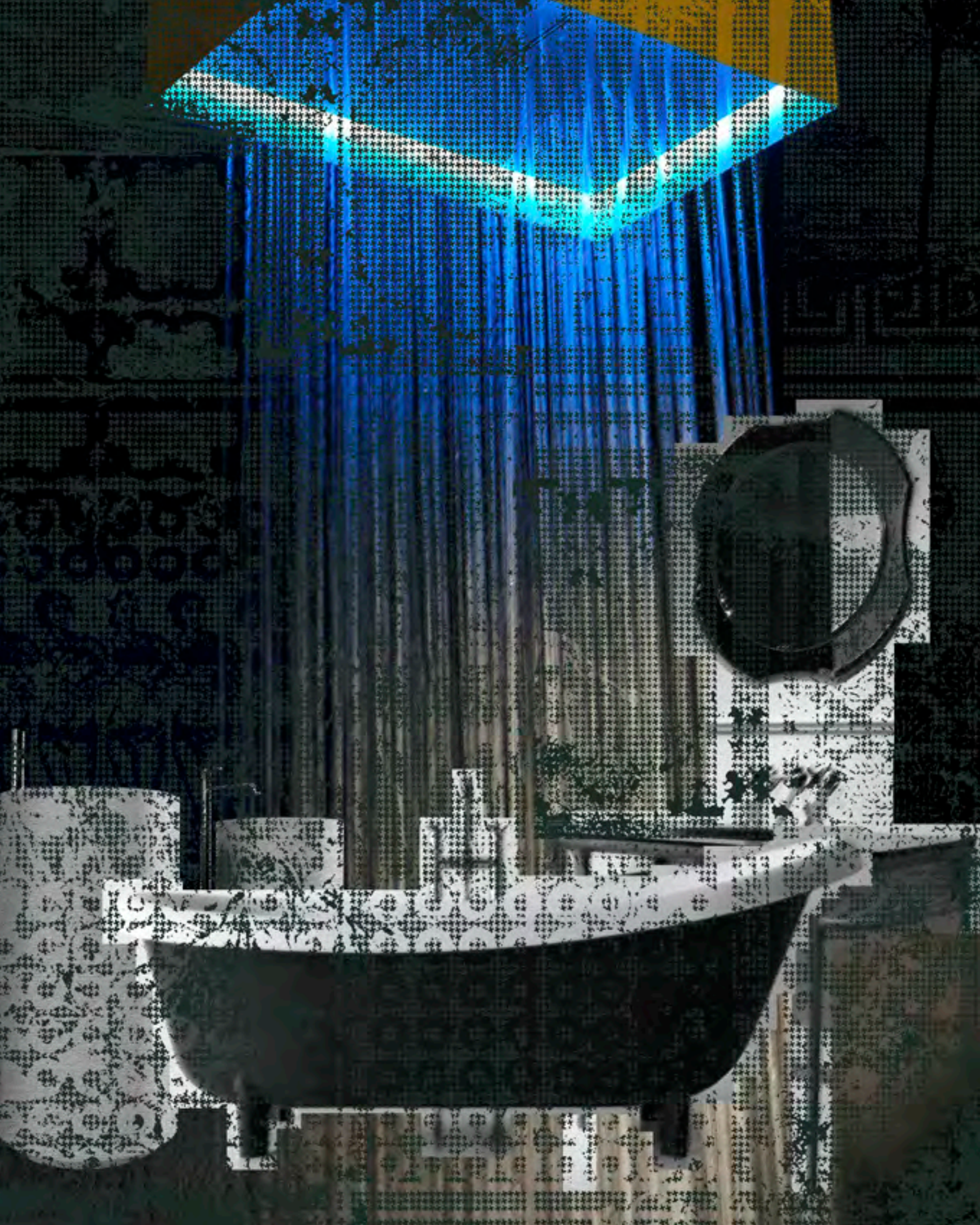



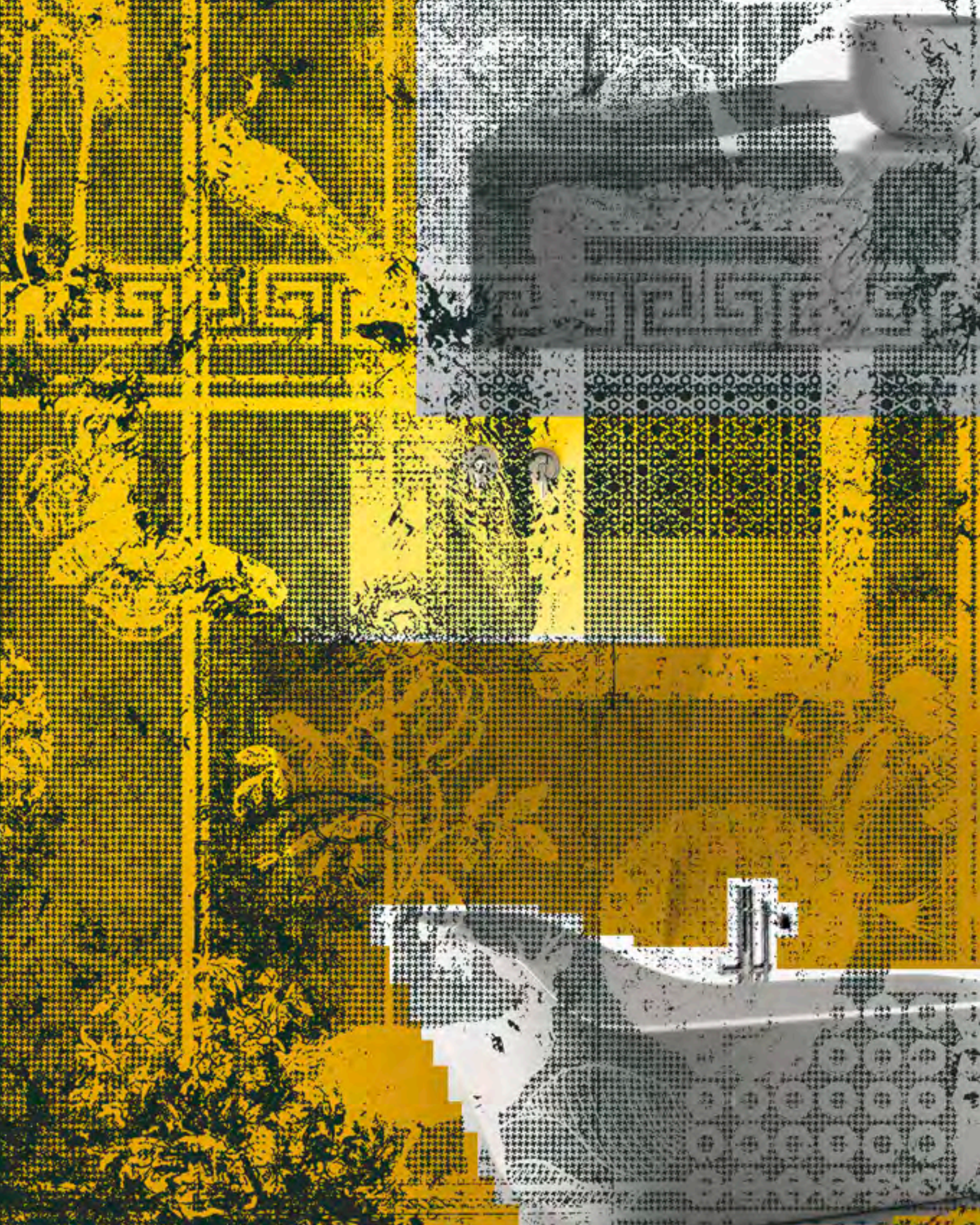







**antoniolupi**



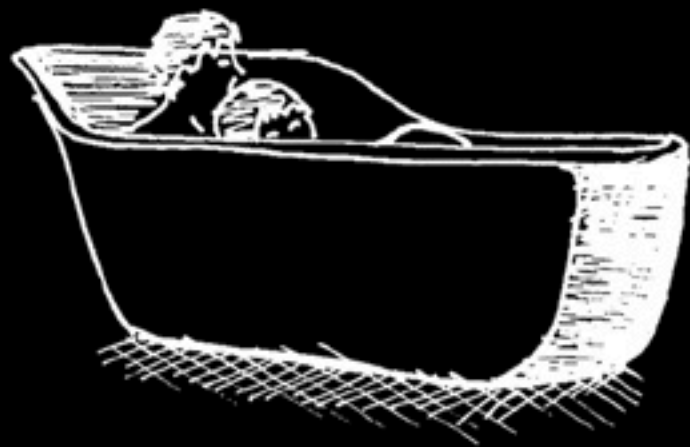

## **INDICE / INDEX**

**4 - 49**

*Azienda / Company*

**50 - 69**

*Termoarredi / Designer Radiators*

**70 - 89**

*Pensili e complementi d'arredo / Wall cabinets and furnishings*

**90 - 97**

*Librerie / Bookcases*

**98 - 119**

*Sanitari / Sanitary-Ware*

**120 - 127**

*Coldstone*

**128 - 213**

*Top / Top*

**214 - 353**

*Lavabi / Sinks*

**354 - 453**

*Vasche / Tubs*

**454 - 511**

*Piatti e box doccia / Trays and shower enclosures*

**512 - 635**

*Soffioni e rubinetteria / Overhead shower and taps*

**636 - 731**

*Specchiere e illuminazione / Mirrors and lighting*

**732 - 823**

*Accessori / Accessories*

**824 - 829**

*Finiture / Finishes*





**ARCHITETTURA SARTORIALE IN BAGNO**  
***TAILORED ARCHITECTURAL DESIGN IN THE BATHROOM***

Prodotto interamente in Italia  
*Entirely made in Italy*

**antoniolupi**



## 1 - Non solo prodotto: total tailor made!

*“Oggi tutti usano così frequentemente il termine sartoriale, che mi sono stancato di parlarne. Noi siamo nati così, abbiamo fatto tutto per rafforzare questa identità ma le abbiamo affiancato un approccio industriale rigoroso fatto di certezza e affidabilità, di rispetto per il lavoro di tutti e per le tempistiche di consegna: un servizio che conta come il prodotto”.*

Quante volte abbiamo sentito dire che in un mercato così competitivo il servizio finisce per essere uno degli aspetti fondamentali nel processo di scelta e nelle modalità di acquisto di un prodotto. Troppo spesso le aziende italiane (prese come specchio del nostro paese) sono state accusate di scarsa affidabilità, di pressapochismo, di ritardi cronici, di mancanza di organizzazione. Tutti riconoscono il valore del design italiano e più in generale del Made in Italy, ma questo non basta più. Nessuno discute sulla qualità dei nostri prodotti, ma sono troppe le incertezze attorno a quanto succede dopo, quando il prodotto è finito, pronto per essere spedito. I prodotti non finiscono di vivere quando sono stati consegnati, durano per molti anni, hanno magari bisogno di aggiornamenti, manutenzione, sostituzioni di componenti... insomma il loro ciclo di vita deve essere seguito con la stessa attenzione che è stata messa per produrlo. All'antoniolupi il servizio conta come il prodotto. Sono due aspetti complementari ed equiparati nell'attività dell'azienda, sono due facce della stessa medaglia che non possono vivere separatamente. Per questo l'azienda ha da sempre concentrato notevoli sforzi sulla messa a punto perfetta del processo produttivo, durante il quale l'attenzione al cliente deve rimanere inalterata: dall'ordine alla lavorazione su misura, dalla personalizzazione estetica all'imballaggio, dalla spedizione, anch'essa personalizzata al post vendita. Un meccanismo oliato in cui tutto deve funzionare alla perfezione, ancor di più per una realtà che lavora solamente just in time, ordine su ordine e che per questo deve saper far fronte a picchi di lavoro anche improvvisi che non possono in nessun modo influenzare negativamente il servizio.

A partire dalle tempistiche di consegna. In 30 giorni antoniolupi consegna in tutta Italia, in 40 in tutto il mondo qualsiasi tipologia di prodotto o collezione. Un tempo davvero breve per una produzione che fa del dettaglio e dell'alta qualità il proprio tratto distintivo, tenendo conto che spesso le richieste obbligano a realizzare elementi su misura sia per dimensione che per finitura o colore. A prodotto finito anche l'operazione di imballo necessita di particolari attenzioni perché non sono rare contestazioni e segnalazioni di rotture dovute a un cattivo trasporto. Per prevenire questi problemi, antoniolupi realizza un imballo dedicato ad ogni tipologia di prodotto e di mezzo di spedizione, rafforzandolo in alcuni casi con supporti e casse lignee e attuando accorgimenti che possano semplificare le operazioni di carico e scarico del trasportatore.

Il servizio non si ferma alla consegna, ma prosegue con un'assistenza precisa e puntuale che interviene in qualsiasi caso di problema e affianca il cliente fino alla sua realizzazione.

La tipologia particolare di alcuni prodotti necessita infatti di una continua collaborazione con il committente, sia esso un privato o un progettista, perché l'integrazione tra prodotto e spazio può richiedere interventi in fase di posa o a posa completata. Il cliente è per antoniolupi davvero al centro del progetto e per offrire una miglior consulenza e affiancarlo fin dalle prime fasi del progetto, quando è possibile, l'azienda sta producendo un grande sforzo a livello distributivo, a partire dai propri showroom monomarca. È in questi contesti infatti che si esprimono al meglio tutte le potenzialità dell'azienda, perché essere un punto di riferimento per architetti, professionisti ma anche consumatori finali vuol dire poter entrare in un rapporto empatico con loro, vuol dire poter proporre soluzioni che magari non avevano preso in considerazione, vuol dire limitare notevolmente errori dovuti a cattiva informazione, incomprensioni o preconcetti difficili da scardinare.

Non è semplice spiegare come un lavabo possa essere totalmente integrato nel muro o un camino possa trovare posto in una parete senza avere la possibilità e lo spazio di mostrare come ciò accada effettivamente. Gli showroom antoniolupi sono spazi accoglienti ma allo stesso tempo funzionali, isole di relax nel caos metropolitano nel quale immergersi nel total look dell'azienda, ma anche luoghi e persone dalle quali si è sicuri di trovare una risposta, per risolvere un problema, per chiarire un dubbio, per validare una scelta progettuale. Con l'inaugurazione nel 2008 dello showroom a Milano, antoniolupi ha chiuso il cerchio proponendo un'immagine integrata e riaffermando la propria identità in un settore in cui non è per nulla semplice costruirsi uno stile riconoscibile. Nella capitale del design la casa di antoniolupi è uno spazio in cui sviluppare un rapporto privilegiato, in cui prendersi del tempo per decidere, in cui essere seguiti passo passo. Uno spazio che verrà presto ampliato per offrire un servizio ancora migliore, per poter dedicare a ogni protagonista della gamma il giusto spazio e la perfetta contestualizzazione. Milano è stato solo il punto di partenza di una rete che si è sviluppata rapidamente e che oggi può contare sui negozi monomarca di Chicago, Miami, Monaco e Torino, ma che presto potrebbe ampliarsi ulteriormente.

Una scelta, quella di puntare sul monomarca, che non dimentica i distributori

più tradizionali, anzi li affianca per sviluppare corner dedicati, per alimentare la formazione del personale, per promuovere quel processo di collaborazione e di crescita reciproca che è la condizione indispensabile perché la filiera possa completarsi al meglio. “Siamo pronti ad aprire nuovi shop in shop a condizione di trovare partner disposti a dedicare ai nostri prodotti il 60-70% del negozio. La comunicazione e la presenza agli eventi fieristici vanno nella stessa direzione. Antonioluti porta nel mondo il proprio modo di interpretare e vivere l'ambiente bagno e lo fa con tutti i mezzi e le modalità disponibili, cercando di sfruttare al meglio le opportunità, di dare il massimo in ogni occasione e di fare ancora meglio in quella successiva...solo così si continua a crescere.”

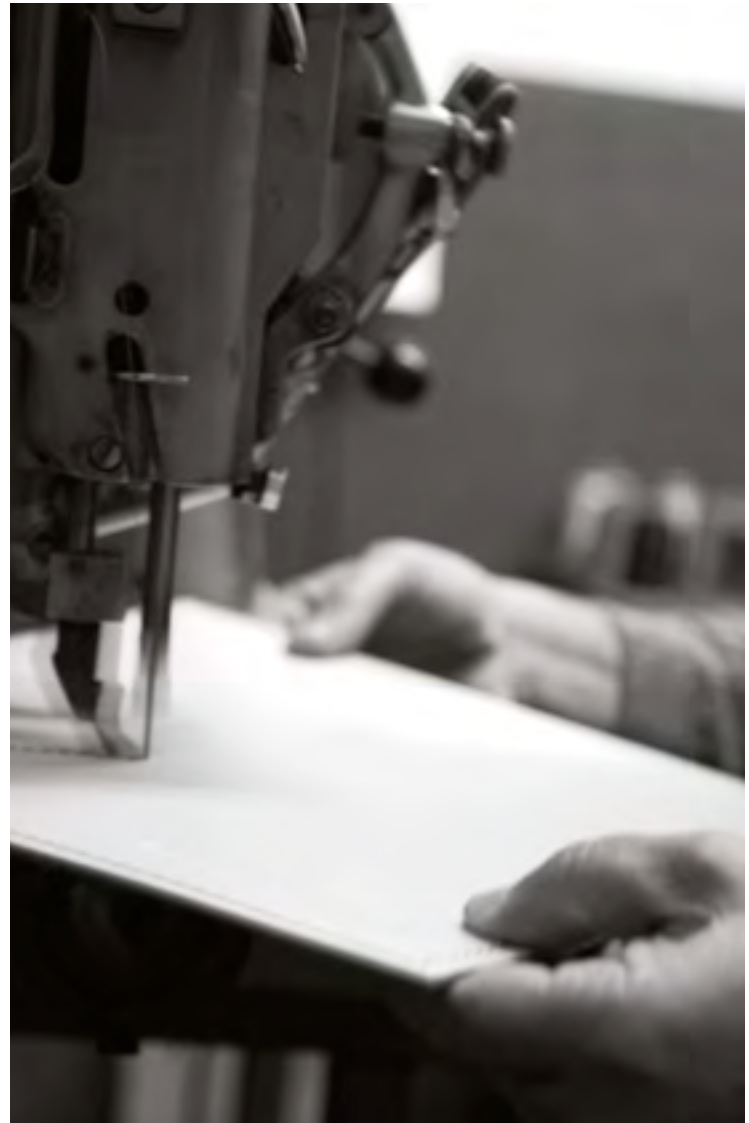



## 2 - 100% fatto in Toscana

*“Dobbiamo dare il nostro contributo per valorizzare un territorio unico fatto di eccellenze e di straordinaria bellezza. Perché la qualità è l'unica cosa che può salvare il nostro paese e le nostre aziende, perché solo ripartendo dalla nostra terra si può andare lontano”.*

Molte delle antiche civiltà sono nate lungo un corso d'acqua. Quando i popoli sono diventati stanziali hanno spesso scelto di insediarsi proprio in presenza di un fiume, con il quale hanno dovuto rapportarsi, costruendo la loro storia in sintonia con i suoi elementi. Molte aziende sono nate vicino all'acqua, perché dall'acqua e dalla sua forza primordiale traevano l'energia per muovere le macchine, per avviare la produzione, per alimentare i processi. La Valle dell'Arno è un territorio unico, una culla di etnie, una fucina di conoscenze tramandate lungo le generazioni, di competenze uniche. Attraversata dalla via Francigena, è un libro aperto nato dalla sovrapposizione di racconti, di passaggi anche cruciali della civiltà, di protagonisti assoluti della nostra storia. È un luogo dell'eccellenza sotto molti aspetti, enogastronomici, paesaggistici, culturali e artistici.

Antoniolupi è un'azienda toscana, prima che italiana, è un patrimonio locale prima che internazionale, è un crogiolo di elementi diversi che concorrono alla definizione dell'eccellenza. Perché forse senza questo humus nulla sarebbe potuto essere, forse solo grazie alla passione e alla caparbità degli uomini e delle donne di questa terra è stato possibile dare vita a una realtà che è oggi un vanto per tutto il territorio e un testimone del Made in Italy, quello vero, nel mondo.

L'azienda si inserisce in un contesto ricco ma difficile, un luogo dalle grandi potenzialità ma dalle problematiche spesso irrisolte, un paesaggio fatto di splendide colline ma anche di aree per molto tempo inutilizzabili, come il Padule di Fucecchio (paese in cui ebbe inizio la storia di Antonio Lupi), la più ampia palude interna italiana con un'estensione di circa 2000 ettari. Grazie alla posizione strategica e alla particolare morfologia, il Padule rivestì da sempre grande importanza nelle sorti delle popolazioni che hanno occupato il territorio, come nel Rinascimento, quando Cosimo de' Medici ordinò la chiusura del fiume Usciana allo scopo di realizzare una grande "pesciaia" dove poter ottenere una pesca abbondante. Il risultato fu una grande palude, con l'acqua a ricoprire gran parte delle aree circostanti con la conseguente protesta dei proprietari terrieri. Ma anche in epoca più recente la palude fu teatro di eventi, spesso tragici, di grande rilevanza per il nostro paese. Come nell'Agosto del 1944, quando nel giro di poche ore si completò una delle stragi più efferate e sconosciute compiute dai nazisti in territorio italiano; durante il cosiddetto Eccidio del Padule di Fucecchio furono uccise 174 persone, rastrellate nei vari paesi della zona.

Sono numerose le testimonianze storico-artistiche che raccontano un passato glorioso, frutto dell'alternanza di dinastie importanti, della presenza di artisti di grande livello, dell'incontro tra potere e cultura, tra ricchezza e creatività. La Villa Medicea di Cerreto Guidi, oggi sede del Museo della Caccia e del Territorio, fu costruita su un precedente castello dei conti Guidi, che diedero il loro nome alla località. Progettata dall'architetto fiorentino Bernardo Buontalenti (anche se l'attribuzione non è del tutto certa) come residenza di caccia di Cosimo I, la villa assume in realtà l'aspetto di un imponente fortezza grazie a due enormi scale simmetriche a zig zag che delimitano il fronte principale. Alle corti rinascimentali come quella dei Medici va il merito di avere saputo "catturare" i migliori talenti del nostro paese e di aver commissionato loro opere indimenticabili che ancor oggi rappresentano una fonte di grande attrazione del nostro ineguagliabile territorio, spesso poco valorizzato. Era uomo di corte anche il cittadino più illustre di Vinci, un paese a soli 10 km dalla sede di antoniolupi. Leonardo (da Vinci appunto!) è l'artista universale per l'eccellenza, è l'uomo che ha saputo associare teorie umanistiche, capacità espressive e senso pratico per lasciarci alcune delle più belle opere e delle più importanti invenzioni ingegneristiche del patrimonio mondiale: dalla Gioconda al Cenacolo, dal Codice Atlantico alle macchine leonardesche, dall'invenzione di dighe e sistemi di gestione delle acque ai congegni militari. Un'infinità

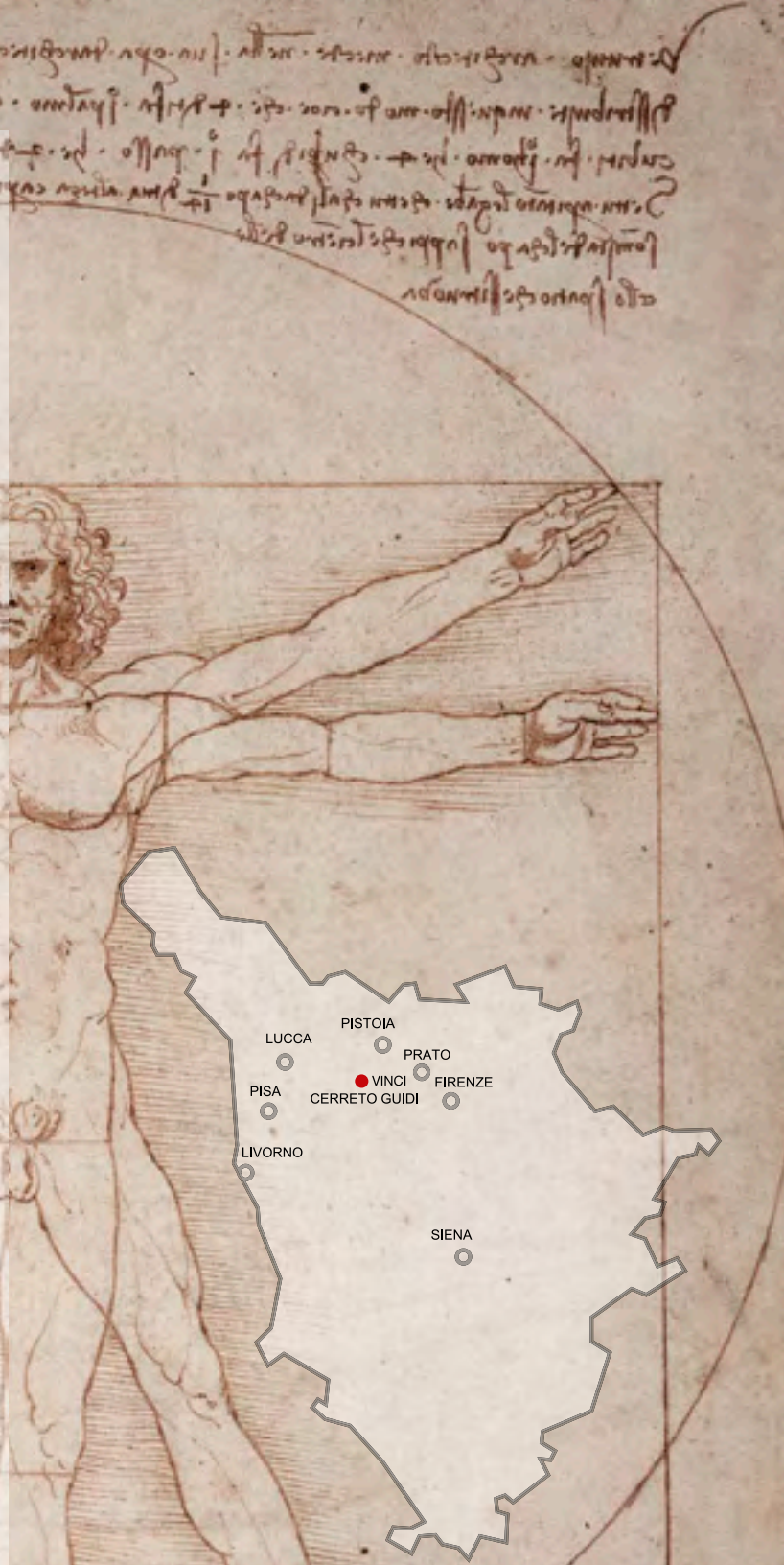

di quelli che oggi chiamiamo brevetti, una produzione continua di idee, soluzioni pratiche, innovazioni in qualsiasi settore. A Vinci Leonardo trascorse gli anni della sua fanciullezza, nel contesto toscano si formò il suo carattere si intensificò la sua curiosità, si gettarono le basi per la formazione di un assoluto fuoriclasse della creatività e del progetto. Insomma tanti protagonisti per un territorio le cui vicende sono state narrate con arguzia da una delle penne più taglienti del giornalismo italiano, da quell'Indro Montanelli, nato a Fucecchio, che incarnava alla perfezione il carattere vulcanico e a volte burbero di questa gente, lo spirito libero, la passione incondizionata per il proprio lavoro e per la propria terra ma anche la volontà di lottare sempre per quello in cui si crede.

In questo contesto così particolare, così ricco di operosità e cultura del fare, antoniolupi si inserisce come punto di riferimento, come interprete della produttività e della creatività tutta italiana, come testimonial assoluto dell'eccellenza di questa terra.





### 3 - Ieri Antonio Lupi, oggi antoniolupi

*“Coraggio e passione, visione e concretezza, tradizione e innovazione, vittorie e sconfitte: una storia di uomini prima che di progetti, un’azienda fatta di persone che trasformano i sogni in prodotti, un racconto che parte da un uomo e arriva a un brand, come sempre fatto di uomini...”*

Una storia fatta di coraggio e passione, di intuizioni e costanza, di individualità e partecipazione, in una sola parola di visione. La visione non è mai mancata nella storia di quella che oggi è antoniolupi ma che molti anni fa nasceva dall’intuito di Antonio Lupi, il padre dei quattro fratelli che oggi guidano l’azienda. Come tutte le storie di successo non è stato un percorso semplice, tutt’altro, è stato un cammino tortuoso, fatto di tappe importanti, di parziali cadute, di riprese, di consolidamento, di affermazione. Una storia basata sulle idee, quelle giuste, spesso vincenti, sempre innovative. Antonio Lupi, nato a Vinci, il paese di Leonardo, inizia nel 1950 la sua attività in un piccolo magazzino di Fucecchio, a pochi chilometri dall’attuale sede di Stabbia. A soli 18 anni avvia la produzione di cristalli e vetri per l’arredo; è un momento di svolta per una famiglia di origine contadina, una vera rivoluzione in un territorio, quello della Val d’Arno, nel quale le attività tipiche interessavano settori molto diversi. Antonio inizia a proporre ai suoi clienti i suoi primi prodotti, dai ripiani per comodino alle prime vetrinette e si costruisce una piccola rete commerciale per soddisfare le richieste dei propri clienti. Dai vetri agli specchi per il bagno il passo è breve, anche se complicato. Siamo negli anni 60, gli anni del boom economico che ha radicalmente cambiato il volto del nostro paese e ha avviato una radicale trasformazione delle tipologie dell’abitare, con il passaggio epocale dal bagno in comune alla stanza privata presente in ogni casa. Il successo è immediato e l’azienda si espande rapidamente trasformandosi da terzista in produttore di arredo bagno con il nome di Cristal Lupi Luxor. Lo spazio inizia a stare stretto e l’azienda individua nel territorio di Stabbia, dove all’epoca tranne la strada non c’era nulla, lo spazio ideale per la sua espansione. La Cristal Lupi Luxor apre il nuovo stabilimento nel 1969. È il definitivo passaggio dalla dimensione artigianale a quella industriale, da Lupi arrivano a lavorare oltre 300 persone (quasi tutte di Stabbia o degli abitati vicini) e il radicamento tra l’azienda e il luogo si fa ancora più intenso, quasi indissolubile. Il successo dura parecchi anni, l’offerta si amplia rapidamente comprendendo oltre agli specchi anche lampade, piccoli accessori e anche accappatoi. Siamo agli albori di quell’idea di total look che troverà compimento solo negli anni duemila, ma già l’impronta era forte, l’obiettivo era chiaro, il percorso futuro era tracciato. L’azienda apre i suoi primi punti vendita diretti varcando anche il confine con una sede a Cannes per presidiare il mercato francese. Anche lo stabilimento di Stabbia si espande e l’azienda diversifica la propria produzione inserendo anche la realizzazione di vetrocamera per l’edilizia e organizzando un’attività commerciale del vetro. Il mercato però si evolve in direzione opposta e l’azienda non riesce ad adeguarsi. Il periodo difficile culmina con l’Amministrazione Controllata del 1981 (vi rimarrà fino all’83) e proprio nel momento più difficile inizia la risalita. Due figli di Antonio, Nello e Patrizia, sono già in azienda rispettivamente alla consociata francese e all’ufficio acquisti/gestione fornitori ma è l’ingresso di Andrea, il secondogenito, ha segnare la vera svolta, il punto di discontinuità che ha consentito al meccanismo di rimettersi finalmente in moto. Il suo percorso scolastico era stato a dir poco tortuoso (gli studi di ragioneria imposti dal padre si rivelarono un fallimento) e Antonio lo mette di fronte ad una scelta radicale che cambierà il corso degli eventi... Più che una scelta si tratta di un ultimatum. Siamo nel Settembre del 1981 e quando lo chiama nel suo studio Andrea ricorda come di fronte alla scrivania ci fossero due sedie, entrambe vuote: *“Mi disse. Non vuoi più studiare, quella è la valigetta con i campioni. Si è appena licenziato il nostro agente del centro Italia, vai in giro, fatti conoscere, presenta i nostri prodotti e cerca di venderli”*.

La gavetta che il padre gli fa fare in giro per la Toscana ed Emilia Romagna è dura e non è semplice per Andrea calarsi in questa realtà,

ma capisce presto che è solo il campo a poter dire se si sta andando nella direzione giusta.

E la direzione presa dall’azienda non è più quella giusta. Le cose stanno rapidamente cambiando, nella società come nelle case degli italiani e bisogna fare un salto di qualità. *“Mi rendevo conto che le persone non avevano più bisogno dei nostri prodotti, che tutto stava cambiando e noi eravamo rimasti fermi”*. Con tanta creatività e pochi investimenti (oltre alla pressione di un padre che non condivideva questa scelta) riesce in poco tempo a dar vita a una piccola collezione di sistemi d’arredo bagno e si presenta per la prima volta al Cersaie nel 1983. È un gran successo, Andrea torna con un bel numero di ordini (in quei tempi alle Fiere si vendeva davvero!) e decide che è ora di lavorarci su *“Non era un’opportunità ma la sola possibilità di ripartire, non avevamo scelta. Fummo costretti a iniziare una nuova avventura perché per soddisfare tutte le richieste che avevo avuto in fiera dovevamo iniziare a produrre in modo serio”*. I fratelli lo seguono subito e i Lupi ripartono da Fucecchio, dalle origini, con una nuova azienda, la Gilly di Lupi Patrizia (prendendo spunto dal nome di uno storico caffè di Firenze) e una nuova avventura. Il padre li guarda da lontano, non li segue subito, intuisce che i suoi stanno diventando grandi e hanno bisogno di *“fare da soli”*. In realtà è troppo orgoglioso della sua creazione e non riesce ad abbandonare la nave anche quando è irrimediabilmente andata alla deriva. È testardo, come tutti in famiglia, e ci vuole un po’ per convincerlo ma alla fine i figli lo fanno sentire importante, lo coinvolgono, lo rendono partecipe del progetto e lui si rimette in discussione, riparte da capo. Il suo nome conta ancora nel territorio, quello che ha fatto, per molti, non si cancella. Riparte viaggiando per proporre gli articoli della nuova Antonio Lupi... Siamo nel 1988 e da un paio d’anni l’azienda aveva cambiato nome in Antonio Lupi Collezione Bagno. Antonio ne è il Direttore Commerciale, Patrizia è saldamente all’Amministrazione, Nello e Andrea fanno tutto il resto, Sergio è ancora troppo piccolo per aiutarli...

Il successo è rapido e costante e presto la nuova azienda con 30 dipendenti ha bisogno di spazio. Il cerchio si chiude nel 1991: Antonio Lupi torna a Stabbia, ricomprando parte dell’antica fabbrica nel frattempo andata all’asta. Si riparte da lì, dalla vecchia sede della produzione ma con nuovo slancio, nuove idee, nuove strategie. L’azienda cresce rapidamente e si svincola dai vincoli dettati dai produttori dei sanitari iniziando a presentare i primi lavabi e articolando la propria offerta. Parte da quello che sa fare meglio, dai lavabi in vetro integrati nel piano, ma già dopo pochi anni l’azienda è in grado di proporre la prima collezione di lavabi in ceramica dalle forme geometriche essenziali. È l’avvento del minimale che culminerà nel 2002 con la prima collezione in Corian® e con lo sviluppo dell’idea del bagno completo e sartoriale. Anche con l’avvento dei nuovi materiali l’azienda non dimentica quelli tradizionali come la pietra, il marmo o anche l’alabastro, protagonisti di molte altre collezioni (da Materia a Talamo). Da quel momento è un susseguirsi di innovazioni e collezioni di successo che hanno cambiato radicalmente il modo di concepire l’ambiente bagno: dai mobili Pantarei con la struttura a 45° all’introduzione del fuoco con camini e biocamini, dal primo radiatore, agli affreschi, dai soffioni ai lavabi integrati nella parete. Intanto, nel 2007 a un anno dalla scomparsa di Antonio e della moglie Mara, è stato rivisitato il logo aziendale. Un’operazione importante perché si è deciso di citare la grafica del marchio originario ma allo stesso tempo valorizzare l’affermazione di un brand che è oggi garanzia di qualità, bellezza, passione per l’ambiente bagno. Oggi antoniolupi mette a disposizione dei propri clienti tutto quanto concorre a dar vita a un total look elegante e raffinato, proprio come Antonio aveva sognato all’inizio della sua avventura. I suoi figli hanno realizzato il sogno e la storia può solo continuare...

**lupi**

20

**DIVISIONE ESTERO - RAYON EXPORT - EXPORT DIVISION  
EXPORT-ABTEILUNG**

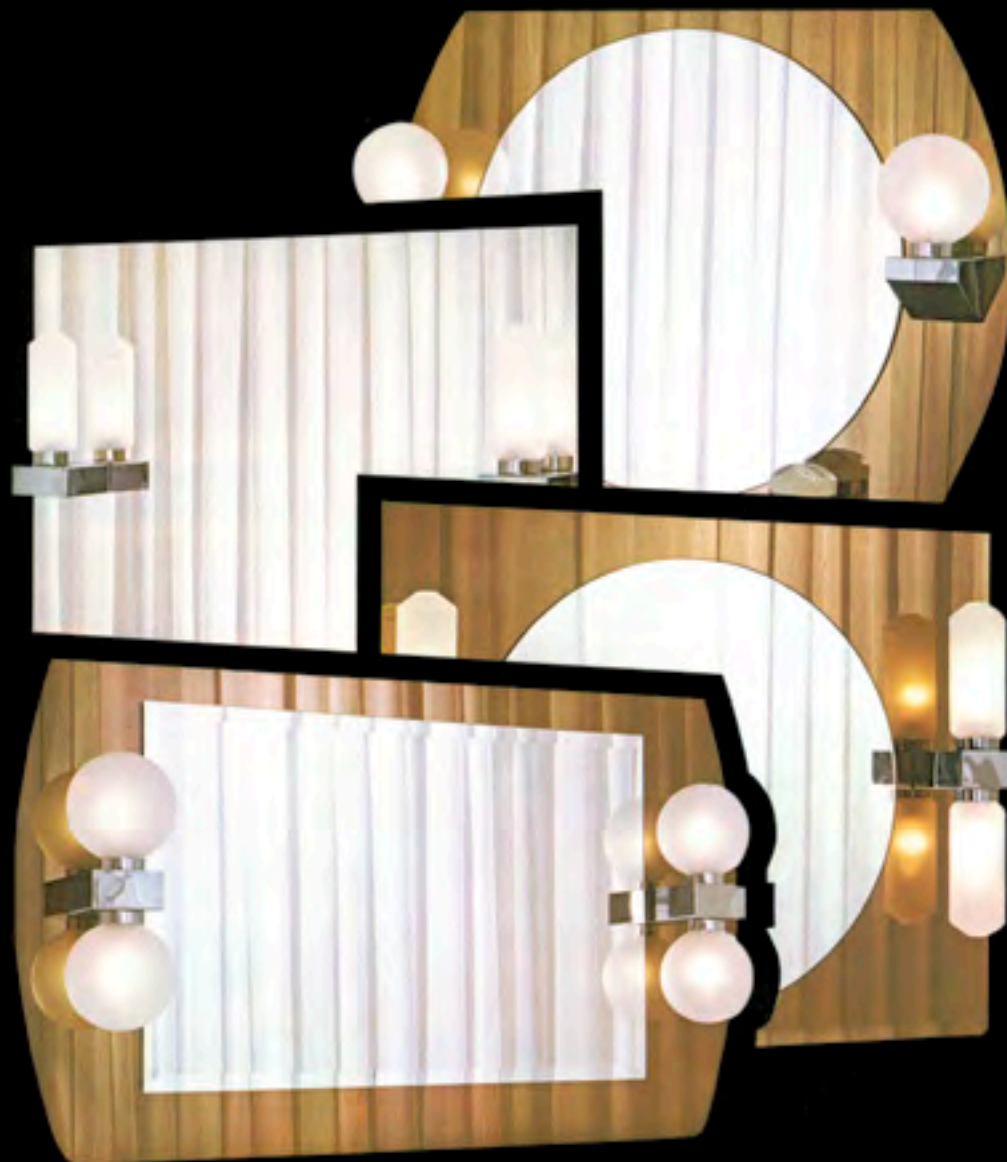





L'azienda negli anni '60.  
*The company in the '60's*



Antonio Lupi nel suo ufficio e fotografato mentre ritira un premio nel 1972.  
*Antonio Lupi in his office and photographed while receiving an award in 1972.*





La foratura  
*Drilling*

La molatura  
*Bevelling*



Il reparto molatura  
*The bevelling area*

Il taglio  
*The cut*





Il reparto montaggio  
*The assembly area*

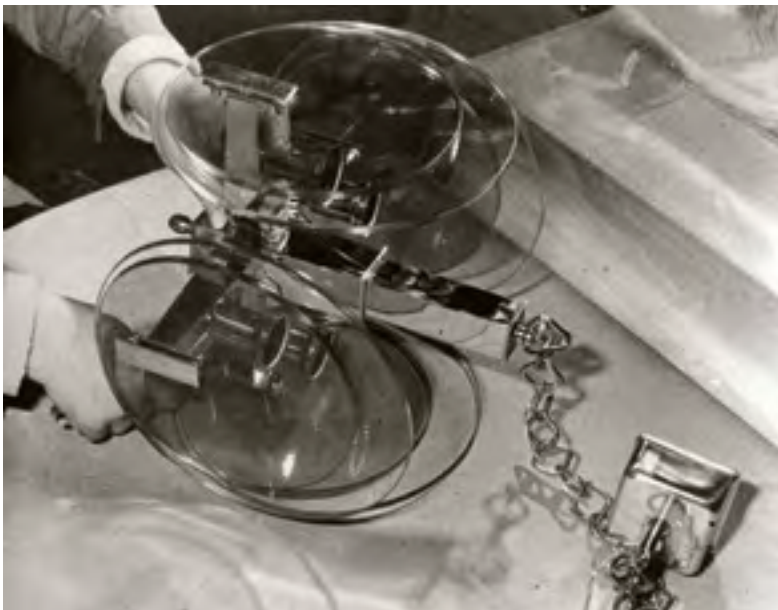

Il reparto imballaggio  
*The packaging area*



Gli uffici  
*The offices*







## 4 - Quattro fratelli, una sola azienda

*“Nostro padre era innamorato del suo lavoro e della sua azienda; vi metteva tutto se stesso, tutte le sue energie, le sue speranze, i suoi sogni. Diceva sempre che bisognava lavorare, sbagliare e imparare. Noi siamo come lui, siamo diversi ma uguali, siamo testardi ma comprensivi, siamo concreti ma sognatori, ma soprattutto siamo prima fratelli e poi imprenditori...”*

Quattro personalità diverse, quattro caratteri distanti, quattro modi di intendere la vita, ma tutti accomunati dallo stesso entusiasmo, dalla passione per le cose belle, dalla convinzione che per ottenerle bisogna spendersi fino all'ultimo, dalla sicurezza di fare solo quello che si sa fare bene, lasciando il resto agli altri. Nello, Patrizia, Andrea e Sergio guidano oggi un'azienda innovativa e proiettata al futuro, una realtà unica nel panorama nazionale e internazionale per la capacità di anticipare tendenze, definire prospettive a lungo termine, determinare cambiamenti d'abitudine nel modo di vivere il bagno e la casa più in generale. I quattro fratelli Lupi sanno che il loro successo parte da lontano, sanno come trarre insegnamento dalla loro storia, sono consapevoli che tutto ciò che si è fatto in passato non si dimentica, anzi è indispensabile per continuare a crescere. Sono i protagonisti della loro azienda, perché la vivono al 100%, a stretto contatto con i collaboratori più fidati. Li trovi sempre in ufficio o in produzione, anche quando te li aspetteresti altrove, sono presenti e attenti, sono responsabili, ciascuno per le proprie competenze, di una parte del business, ma in realtà hanno il controllo su tutto, perché si confrontano spesso e hanno sempre voglia di conoscere, capire, costruire qualcosa di nuovo.

A volte le decisioni da prendere sono importanti e decisive per il futuro dell'azienda, in altri casi il clima è più rilassato perché magari si lavora ad un nuovo progetto e si ha tutto l'entusiasmo verso qualcosa che sta per nascere. Alcuni designer che lavorano con antoniolupi amano dire che in azienda si gioca sul serio, ci si diverte lavorando. Ma quando il gioco finisce, la creatività lascia spazio alla concretezza, alla coerenza, alla garanzia nei confronti del cliente, alla fiducia da non dare mai per scontata.

La suddivisione dei ruoli in azienda è stata abbastanza naturale (Antonio aveva visto giusto molto tempo fa), l'equilibrio interno è regolato da un mix di competenze, creatività e naturali predisposizioni. Andrea è il frontman dell'azienda, è quello che *“ci mette sempre la faccia”*, nel senso più letterale del termine. Estroverso per carattere ma anche riflessivo, creativo ma competente anche negli aspetti più tecnici. Oggi si occupa della progettazione, della ricerca e della comunicazione di antoniolupi. Quella della scuola (ragioneria!) è stata solo una sfortunata parentesi, prima o poi l'indole creativa doveva venire fuori e se la si riesce ad unire a una buona dose di coraggio, può dar vita a cose grandi. Andrea, con i suoi fratelli, ha risollevato l'azienda dai momenti difficili, superando le resistenze comprensibili di un padre che vedeva la sua creazione in difficoltà ma non voleva

accettare il cambiamento. I figli invece hanno deciso che era giusto andare oltre, che per ripartire bisognasse fare altro, che solo così si sarebbe dato un futuro alla famiglia e all'azienda. Un approccio che deriva dalla passione per la ricerca continua dell'idea, dal non fermarsi mai ai risultati ottenuti, dal cercare sempre nuove strade, dall'essere sempre pronti a nuove contaminazioni. Se il bagno sta stretto ad Andrea è perché l'apertura mentale lo porta a cercare sempre cose nuove, a indagare ambiti diversi, a esplorare strade inedite, a non stare mai fermo. L'intuizione fa il resto, fa decidere se seguire una strada o abbandonarla, se credere in un progetto o lasciarlo decantare per un po' e poi magari riprenderlo, dopo qualche anno, quando come si diceva una volta *“i tempi sono maturi”*.

Patrizia, l'unica donna tra i fratelli, si è occupata fin da subito della parte amministrativa dell'azienda. Il padre ne aveva individuato capacità e attitudini e a soli 17 anni, dopo un apprendistato all'ufficio spedizioni le aveva consegnato uno dei ruoli più importanti dell'azienda l'ufficio acquisti. *“Mi sono fatta largo con le braccia, ho dovuto conquistarmi la fiducia di chi non vedeva di buon occhio che la figlia del padrone così giovane ricopriva un ruolo così importante”*. Da allora si è sempre occupata di *“far tornare i conti”*, di tenere a bada l'entusiasmo e la creatività spesso incontrollata degli scatenati fratelli. Un lavoro complicato, un gioco sottile di compromessi, un equilibrio difficile tra i sogni e la realtà delle cose. Anche numericamente è sempre stata in minoranza, forse per questo ha sviluppato autorevolezza e un carattere forte senza dimenticare il proprio ruolo di mamma e moglie, di donna, in un mondo ancora di uomini...

Nello è il maggiore dei fratelli, è il re indiscusso della produzione. È il depositario di tutti i saperi, di tutti gli aspetti legati alle caratteristiche dei materiali, al modo di lavorarli, alle tecnologie tradizionali o innovative. Un carattere più introverso, uno spirito pragmatico. Più taciturno e più silenzioso di Andrea, si apre quando parla di come l'azienda abbia raggiunto un livello qualitativo senza pari, si entusiasma per quello che fanno i suoi uomini sulle linee di produzione, si rallegra per essere riuscito ancora una volta a ingegnerizzare un progetto, a dare forma ai pensieri di suo fratello e dei suoi designer. Nello non scansa i problemi ma li affronta di petto. È stato il primo ad entrare in azienda (a soli quattordici anni!), ad averne vissuto gli esordi, le difficoltà, le riprese. Sicuramente le vicende lo hanno fortificato, fatto crescere. La competenza, quella vera, si costruisce nel tempo, solo lavorando sul campo, attraverso esperienze anche molto diverse e non sempre positive; ma tutto serve a formare l'uomo e il professionista. Si esprime con la concretezza di chi sa, sta in produzione per risolvere problemi, migliorare i processi, affiancare operai e maestranze nella ricerca continua della perfezione. C'è con loro un rapporto schietto, basato sulla fiducia e le poche parole. Basta uno sguardo, un cenno per capire che sempre si può fare meglio. Le nuove tecnologie richiedono un aggiornamento di competenze che non può prescindere una conoscenza complessiva di ogni aspetto della produzione. La passione si vede nell'attenzione con cui tiene sotto controllo i dettagli e il complesso, con la quale passa dalla scala del dettaglio alla visione







# antoniolupi

complessiva dell'organizzazione e delle tempistiche produttive.

Sergio è il più piccolo dei fratelli e non di poco (con Nello ci sono 18 anni esatti di differenza!). Nato nel 1977 è entrato inevitabilmente per ultimo in azienda. *“Siccome ero troppo bravo a scuola, a 13 anni Andrea e Nello mi presero e mi insegnarono cosa avrei dovuto fare da grande. Per un bel po' di tempo mi hanno tenuto sotto controllo, ora sono libero di prendere le mie decisioni in autonomia anche se il confronto con loro è occasione continua di crescita e miglioramento per tutti. Solo attraverso la condivisione e lo scambio di idee riusciamo ad ottenere i risultati migliori”*. Oggi Sergio si occupa dei progetti speciali e del contatto con i clienti, praticamente di tutto quanto avviene in azienda perché tutti i progetti sono per antoniolupi speciali. E' grazie alla sua competenza che l'approccio sartoriale attorno al quale ruota tutta l'attività prende forma nei diversi progetti.

Insomma ognuno ha trovato la sua strada. Attraverso la fatica, gli errori, ciascuno dei quattro fratelli è oggi un professionista preparato, serio, competente. Il merito è senza dubbio del padre e della sua capacità di spendersi totalmente per ciò in cui si crede.

Sicuramente l'insegnamento più grande di Antonio e di sua moglie Mara, sposata nel 1957 e scomparsa con lui nel 2006, è stato un'altro ed è giusto che sia Patrizia a ricordarlo *“Prima di essere soci ricordatevi che siete fratelli, amava ripetere. Il babbo ci ha insegnato a stare insieme, diceva sempre che l'unione fa la forza, che solo uniti saremmo andati lontano. Noi non l'abbiamo deluso, penso sia molto contento di quanto abbiamo fatto”*.

Ora ci sono i nipoti...la terza generazione. Sono ancora piccoli per essere messi alla prova ma Andrea, Patrizia, Nello e Sergio sono già all'opera per il loro progetto più importante e difficile: trasmettere loro la passione, la voglia di fare e l'amore per l'azienda, far capire fino in fondo cosa vuol dire essere parte di antoniolupi...



**lupi**

50050 - STABBIA (F)  
Via Maremmana, 7 tel. (0571) 556195 - 556196 - 556197 -  
556198 - 500003 - 506007

00100 - ROMA  
Via Rivarone, 108 tel. (06) 626696 - 626697

50054 - FUCECCHIO (F)  
Via E. Da Fucecchio, 2 (0571) 461 20155

ESPOSIZIONE  
50054 - FUCECCHIO (F)  
Via Prov.le Fiorentina, 74 tel. (0571) 21201

LUPI FRANCE S.&L.L.  
06 - CANNES  
56, Rue Georges Clemenceau tel. 363947 33.25.34

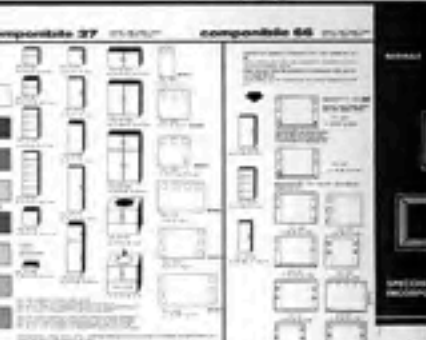





**antoniolupi**

Uffici  
Office



Ingresso  
Entrance gate



Vetreria  
Glassworks



## 5 - Nella corte delle idee

*“Abbiamo ricostruito pezzo per pezzo lo stabilimento di nostro padre, ma non ci siamo accontentati, siamo andati oltre. Volevamo creare un luogo nel quale poter vivere un’esperienza indimenticabile, cercando di far sentire ogni nostro cliente, collaboratore e progettista a casa propria. Perché solo così nascono le idee migliori”*

Da antoniolupi non si va solo per sviluppare progetti o per vedere prodotti; a Stabbia si va per vivere un’esperienza, per immergersi in un’atmosfera creativa e stimolante, si va per conoscere, capire e crescere.

L’headquarter dell’azienda si inserisce nello scenario unico delle colline toscane sviluppandosi per 16.300 mq complessivi sul terreno dove un tempo sorgeva la Cristal Lupi Luxor di Antonio Lupi. L’antico stabilimento, andato all’asta dopo le difficoltà dei primi anni ‘80, è stato faticosamente ricomprato dalla nuova antoniolupi, a partire dal 1991, quando Andrea, Nello e Patrizia decidono di riportare la produzione nel luogo simbolo dell’attività del padre. Non è stato facile riacquisire e sistemare i fabbricati *“Abbiamo dovuto fare tutto da soli - racconta Andrea - molti ci hanno voltato le spalle ma noi volevamo tornare a Stabbia perché era giusto ripartire da lì. Con determinazione e tanto lavoro ci siamo riusciti”*.

Prima gli spazi della produzione e la palazzina degli uffici, poi la nuova vetreria. La casa di antoniolupi prende forma seguendo parallelamente il successo dell’azienda. Le strutture vengono recuperate e adeguate alle nuove esigenze, i capannoni vengono rimessi a nuovo sia dal punto di vista estetico che impiantistico, gli uffici prendono forma per assecondare identità e immagine coordinata della nuova azienda. È l’inizio di un’addizione continua, tesa a soddisfare soprattutto le richieste della produzione, perché lo spazio non basta mai, perché l’idea di Andrea e dei suoi fratelli è quella di dar vita ad un grande spazio aperto circondato da fabbricati, ciascuno con una precisa destinazione funzionale. Come spesso è accaduto nel rinascimento toscano, l’azienda deve diventare un punto di riferimento per chiunque possa dare un apporto di creatività ed esperienza.

Lo schema dell’impianto è chiaro fin da subito: gli uffici occupano il fronte principale mentre le ali laterali ospitano rispettivamente il grande showroom aziendale e la produzione.

Proprio la palazzina degli uffici, che ospita reception, amministrazione, sale riunioni e spazi comuni, diviene ben presto l’anello di congiunzione tra passato e presente grazie ad uno spazio espositivo che viene allestito con un racconto per immagini della storia dell’azienda, dagli esordi di Fucecchio ai giorni nostri. Un percorso per sottolineare le tappe fondamentali di una grande storia, ma anche un modo per accogliere e coinvolgere visitatori e clienti ricordando loro da dove si è partiti, quali strade sono state percorse, quali scelte strategiche sono state fatte, quali risultati sono stati ottenuti.

Sul lato destro della corte si sviluppa lo showroom aziendale. Uno spazio unico per atmosfera e cura dei dettagli, un luogo silenzioso (nonostante la vicinanza della produzione) nel quale immergersi per poter liberare la mente e porsi nelle condizioni migliori per apprezzare le collezioni dell’azienda. Le luci soffuse, la musica di sottofondo, le fiamme dei camini e il rumore dell’acqua permettono al visitatore di vivere un’esperienza di totale relax, consentendogli di toccare con mano lavabi, vasche, sanitari e qualsiasi altro elemento all’interno di ambienti divisi ma uniti, caratterizzati da un mood elegante e raffinato. Una contestualizzazione che consente di immaginare possibili installazioni, di far percepire l’importanza dei colori, delle texture, delle superfici in rapporto con lo spazio circostante. Dalla raffinatezza del vetro alla solidità dei materiali, dall’effimera presenza del fuoco ai riflessi metallici dei metalli: lo showroom viene costantemente rinnovato per ospitare le nuove collezioni che si vanno a integrare con quelle esistenti.

Sul lato opposto si sviluppa la produzione, che si dipana in realtà in più fabbricati. Dalla verniciatura alle linee di montaggio, dall’imballaggio al magazzino delle materie prime e degli accessori, fino allo spazio per le spedizioni. Un layout semplice per un processo che si sviluppa senza soluzione di continuità e che consente di arrivare rapidamente dall’ordine al prodotto finito. Unica eccezione la vetreria, ospitata in uno spazio dedicato un po’ defilato per poter movimentare con agio e sicurezza le grandi lastre di vetro da cui nasceranno lavabi, consolle, specchi e contenitori.



Uffici progettazione  
Project planning office



Restava a questo punto da completare il fronte posteriore, quello che di fatto chiude la corte e che era occupato dalle strutture originali della Cristal Lupi Luxor. Tre grandi spazi con volte a botte di uguale dimensione e disposti parallelamente fronteggiano lo spazio aperto. Si tratta di tre ambienti dalle potenzialità straordinarie, tre spazi industriali completamente liberi, senza divisioni interne, da sfruttare al meglio proprio per la loro estensione e la loro altezza.

L'opportunità si presenta (Giugno 2010 della Pietra e il Fuoco) quando si decide di intervenire su uno di questi spazi un tempo dedicato all'imbballaggio degli specchi. L'esigenza è quella di trovare un luogo per esporre due nuovi protagonisti delle collezioni di antoniolupi: lavabi e vasche monolitiche in pietra e camini. Lo spazio, che si sviluppa per una superficie di 1100 mq, viene ripulito lasciando completamente a vista i caratteri propri dell'architettura attraverso un intervento di raffinata archeologia industriale. L'ambiente è ideale per ospitare le forme scultoree e spesso imponenti di questi elementi, per apprezzare la sensualità della materia, per riconoscere l'unicità di ogni pezzo, ma anche per accogliere, lungo uno dei lati lunghi, i camini e biocamini con uno spazio sufficiente alla verifica del funzionamento di ogni elemento, alla contemplazione della fiamma, alla visione unica di un elemento primordiale. Anche in questo spazio, una sorta di living industriale, un mix tra un grande loft e un hangar o un'officina, l'atmosfera è unica e il calore del fuoco, unito alle superfici levigate della pietra, contrastano con la durezza dello spazio grezzo, in un connubio davvero esclusivo, che dà vita a un ambiente nel quale oltre alla vista vengono coinvolti e stimolati tutti gli altri sensi. La Pietra e il Fuoco, questo il nome del nuovo showroom, si presenta anche esteriormente come una struttura in contrasto con il resto degli spazi. La facciata nera opaca cattura subito l'attenzione una volta entrati nella corte, grazie alla struttura speculare collocata sul fronte opposto e al contrasto con gli altri prospetti completamente grigi.

In posizione centrale, una "lanterna magica" dal 2012 (anno di inaugurazione del Giardino delle Idee) si propone come fulcro dell'intero impianto. È il Giardino delle Idee, uno spazio dedicato al progetto, che ospita gli uffici creativi, il centro ricerca, immagine e sviluppo dell'azienda. Il fronte interamente vetrato di questo edificio che si sviluppa su tre livelli, affaccia direttamente sullo spazio verde della corte delimitato da cipressi e da una siepe di osmantus, ed è proprio l'elemento naturale a caratterizzare questa scatola trasparente. Per accedere all'edificio è infatti necessario attraversare una grande serra con giardino tropicale, nella quale trovano posto piante di diversa provenienza che in questi anni sono rapidamente cresciute dando vita a una giungla ordinata, a un filtro verde tra interno ed esterno che assicura un oscuramento naturale oltre a offrire una vista che rilassa e facilita la concentrazione. Una natura lussureggiante che rende ancora più esplicita la purezza formale e il linguaggio estremamente contemporaneo dell'involucro, caratterizzato dall'assoluta trasparenza ottenuta con innovative lastre di vetro che garantiscono un perfetto isolamento termico e acustico. Al piano terra trovano posto due sale direzionali ed un locale archivio/biblioteca; al primo piano un grande open space ospita una sala riunioni, la stanza del brainstorming e la zona operativa vera e propria con diciotto postazioni. Infine, al secondo piano, una zona cucina/relax sfocia in un grande terrazzo esterno dal quale si può avere una visione completa dell'intera fabbrica e delle colline circostanti. Un luogo per riposare, conversare e isolarsi, ma anche una location ideale per realizzare eventi, impreziosita da un ulteriore giardino con una collezione delle rose più amate da Patrizia Lupi. Oggi, il Giardino delle Idee rappresenta alla perfezione lo spirito che anima antoniolupi. Un'azienda che vuole essere un luogo dove le persone possano lavorare in modo creativo, fare squadra, vivere in armonia con la natura, confrontarsi e migliorarsi in modo da poter continuare ad offrire concetti, prodotti, comunicazione, sempre un passo avanti rispetto ai tempi.



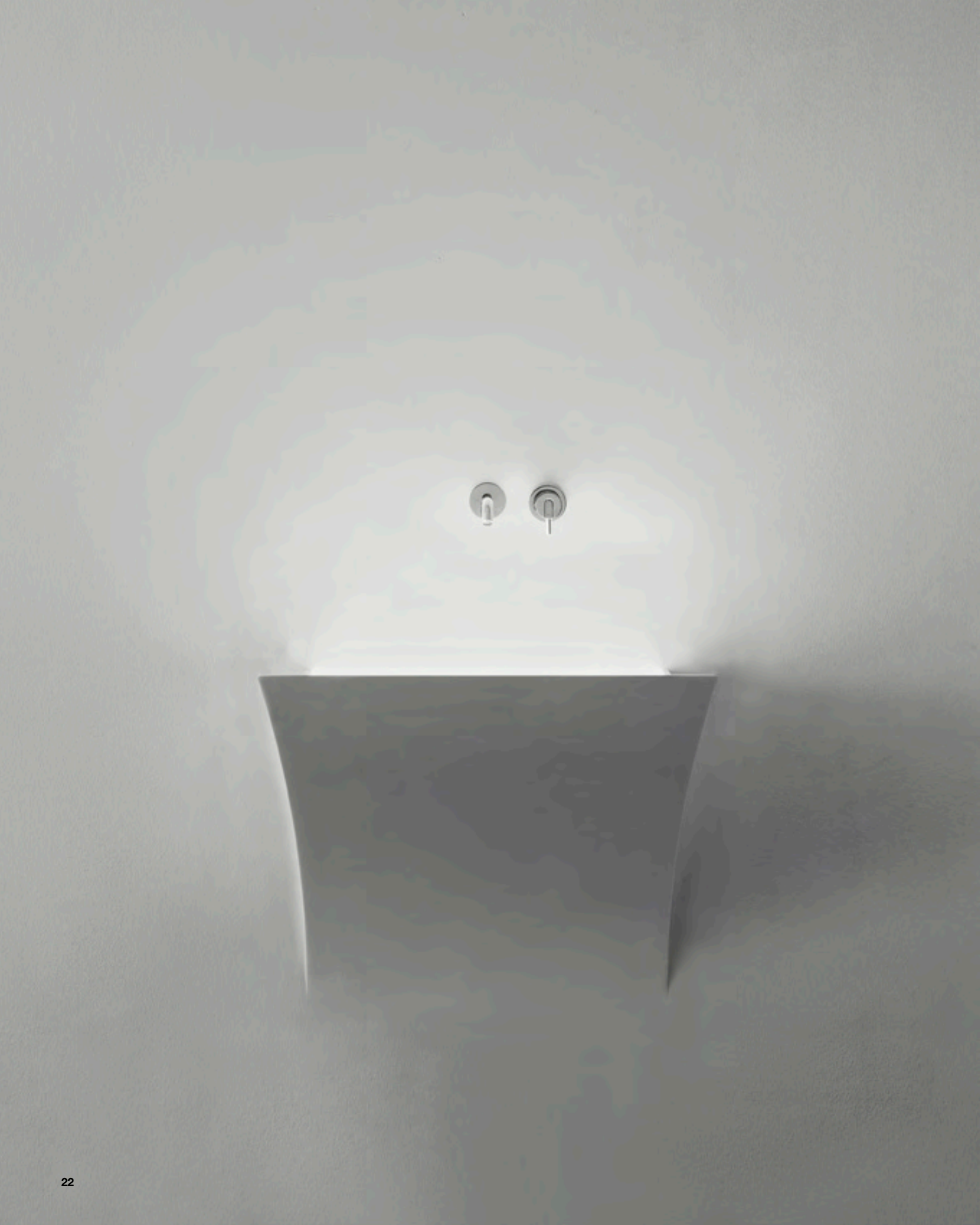

## 6 - Una storia che parte da una visione

*“L’idea e il segno stanno alla base di tutto. Non ho mai fatto una ricerca di mercato, non servono grandi operazioni per capire se il progetto è quello giusto, ho portato avanti solo i progetti che mi piacevano, mi emozionavano. Spesso il prodotto è lì che ti guarda, va solo scoperto!”*

Coraggio e perseveranza per affrontare un percorso spesso tortuoso, flessibilità e coerenza per favorire un approccio sempre diverso mantenendo il proprio stile, capacità di leggere dietro all’idea e prevedere i possibili sviluppi futuri: all’imprenditore, ai suoi collaboratori, a chi si occupa di ricerca e sviluppo prodotti, viene richiesta una visione e antoniolupi ce l’ha. Andrea è un catalizzatore di idee, un “cacciatore” di spunti, contaminazioni o suggestioni da tradurre in prodotti dall’

identità forte, ma capaci di inserirsi come tasselli imprescindibili nel complesso progetto di bagno sartoriale che propone da sempre la sua azienda. Un *“vestito su misura”*, pensato e cucito addosso alle esigenze del cliente, realizzato grazie a prodotti in grado di dialogare tra loro, di integrarsi con lo spazio architettonico, di confrontarsi con le superfici, con la luce e con tutti gli altri parametri che concorrono a definire lo spazio.

Antoniolupi da vita ad ambienti ricchi di fascino ed eleganza, con i quali creare esperienze uniche, suscitare emozioni, raccontare storie... *“Mi piace parlare di progetto, non di prodotto e per farlo amo coinvolgere professionalità diverse: architetti, designer, grafici, tecnici, chiunque possa portare un contributo alla costruzione del progetto. Non vogliamo sostituirci a loro ma affiancarli per creare insieme qualcosa di unico e magico”* dice Andrea. Ogni progetto si traduce in una collezione, in una gamma di prodotti, tutti nati in modo diverso: alcuni hanno seguito un percorso di ricerca più tradizionale, altri invece sono cresciuti grazie alla capacità di Andrea di andare al di là dello schizzo o del modello che veniva proposto dai designer o dai progettisti; alcuni sono stati commissionati a designer di cui si aveva fiducia, altri sono arrivati dalla libera iniziativa dei progettisti. In tutti i casi l’approccio rimane lo stesso *“Ci sono designer più formali e altri più tecnici. L’azienda deve sempre avere il controllo di tutto quello che si può o non si può fare, è inutile rincorrere sogni irrealizzabili o affrontare progetti che non sono nelle nostre corde. Lo stile e la mano dei designer sono differenti. Alcuni hanno un gesto più morbido e barocco, altri un gusto più minimale e raffinato come nel dna dell’azienda. In entrambi i casi il nostro ruolo è quello di aggiungere valore all’idea di partenza, cercando un confronto schietto e sincero anche con chi appare distante dalla nostra idea di stile”*.

È stato così per molte collezioni come per Talamo di Domenico De Palo, proposta inizialmente come una serie di sedute per outdoor e poi diventata vasca e lavabo in pietra apricena. *“Cercavo qualcuno che sapesse estrarre il meglio dalla pietra della mia terra. Sapevo che antoniolupi poteva farlo. Avevo in mente una serie di arredi per l’esterno, ma ero nella casa del bagno e il destino del mio progetto era già scritto...”*. O meglio, non era ancora scritto ma presto lo sarebbe stato *“Ricordo ancora quel giorno del 2008 - racconta Andrea - Domenico venne da me con una serie di modellini in pietra per una collezione di arredo outdoor e io gli dissi subito che era nel posto sbagliato. Rimasi comunque a guardare quei modellini perché mi piacevano, avevano una bella forma ed erano ben fatti...ed ecco l’idea. Dissi a Domenico che la collezione era già sotto i nostri occhi, bastava scavare i volumi che aveva proposto e avremmo ottenuto vasca e lavabo. Così è nata Talamo che abbiamo declinato successivamente anche in Cristalplant®”*.

Un sodalizio, quello con De Palo, che ha visto altre occasioni di confronto, di iniziale sorpresa e senso di spaesamento davanti alle proposte del designer, ma poi di approfondimento e inizio di un percorso che ha portato ad alcuni dei pezzi più importanti della gamma di antoniolupi.

*“Quando mi propose di indagare il tema del fuoco e in particolare di sviluppare una collezione di camini a bioetanolo mi chiesi subito: ma un’azienda che fa bagni che ci sta a fare col fuoco? Non avevamo competenze, non sapevamo da che parte cominciare, non avevo idea di come comunicare e commercializzare questo tipo di prodotti. Ma il segno di Domenico mi convinse ancora una volta, quel taglio nella superficie era così elegante ed essenziale che valeva la pena provarci. Nessuno aveva ancora portato il fuoco nella stanza da bagno. Volevo raccogliere la sfida”*.

Il coinvolgimento del maestro fumista Massimo Pistolesi è stato fondamentale per poter colmare le lacune specifiche in materia. Insieme all’azienda ha messo a punto tutta la parte tecnica della collezione di biocamini Il Canto del Fuoco e il suo apporto è stato decisivo anche nel 2010 per il progetto dei camini a legna Skema di Mario Ferrarini.

Come spesso accade in antoniolupi, un progetto non è mai fine a sé stesso, non si conclude con la realizzazione del prodotto, ma prosegue la propria storia influenzando anche proposte successive.

Il tema dell’incasso a parete ha costretto l’azienda a un lungo lavoro sull’integrazione tra spazio costruito ed elementi che lo compongono. Un

diverso modo di leggere il progetto, una diversa modalità di intervento che vede l’azienda affiancare il progettista d’interni sin dalle prime fasi perché solo così questi elementi possono esprimersi al meglio.

Ribaltando il segno de Il Canto del Fuoco e sostituendo l’acqua al fuoco ecco che prende vita la collezione di lavabi Strappo (2012), oggetti eleganti che escono dalla superficie muraria senza soluzione di continuità. Realizzati interamente in Corian®, vengono poi stuccati e rasati per scomparire nella parete.

Tipologia diversa ma stesso tema per la collezione di accessori per il bagno Sesamo dello Studio Arkimera, un progetto nato in occasione del Salone del Mobile 2012, durante il quale il giovane studio, presente al Salone Satellite, presenta ad Andrea un nuovo concept nato da un progetto di ricerca. Dall’idea a un serie di prodotti che hanno rivoluzionato il concetto dell’accessorio eliminando tutto quanto era superfluo per mostrarsi solo al momento dell’effettivo utilizzo. Presentati dopo soli cinque mesi di sviluppo al Cersaie dello stesso anno, consentono un’integrazione estetica degli elementi che si nascondono nel muro e sono riconoscibili solo dalle sottili linee perimetrali delle nicchie.

Sempre dal tema dell’incasso, questa volta a soffitto, erano nati nel 2011 i soffioni Meteo di Nevio Tellatin. Un progetto molto complesso dal punto di vista tecnico, emblema della velocità e della capacità dell’azienda di mettersi al servizio del progettista. L’effetto pioggia creato dall’acqua trasforma un segno minimale in un’esperienza dal forte valore emozionale, in perfetto stile Lupi. È però con Exelen, progetto di Oscar e Gabriele Buratti, che si esprime al meglio il concetto di sartorialità dell’ambiente bagno e di contaminazione tra elementi e materiali, funzioni ed esperienze. *“Ho scelto lo Studio Buratti per la loro capacità di lavorare a diverse scale del progetto. Per questa collezione avevo bisogno di qualcuno in grado di leggere lo spazio nella sua complessità e interezza, in grado di percepire il valore delle proporzioni, gli ingombri, i rapporti tra pieni e vuoti. In realtà il nostro rapporto nasceva da un progetto molto diverso. Con Abol li avevo messi alla prova per reinterpretare il sanitario in ceramica partendo da un sedile in resina”*. Exelen è una collezione integrata in cui tutti i pezzi dialogano fra loro perché coerenti e coordinati formalmente, in cui i tratti decisi e rigorosi e le forme morbide e avvolgenti consentono di formare combinazioni inedite per progetti *“su misura”*.

E siamo al 2014 all’ultimo progetto presentato dall’azienda. *“Avevo bisogno di un progetto che potesse abbracciare un’area di gusto un po’ lontana dalla nostra e da uno stile eccessivamente essenziale e pulito. Nel 90% del mondo i bagni si arredano con elementi di stile classico, dovevamo una risposta anche a loro”*. Un progetto difficile perché diverso, una reinterpretazione, questa volta formale, del classico/barocco più spinto in chiave contemporanea. Andrea individua in

Roberto Lazzeroni il progettista ideale per quest’occasione e gli lascia carta bianca imponendo una sola condizione. *“Era da tempo che volevo rieditare gli specchi di mio padre, dissi a Roberto che dovevamo partire da lì, che dovevano essere il punto di partenza della collezione attorno al quale costruire una proposta di linguaggio diverso”*.

ILBAGNO è una collezione per un bagno borghese, romantico, come ama definirlo Andrea, una proposta meno rigorosa e minimale che consente di recuperare la memoria di immagini conosciute, gli stili di un nobile passato, le suggestioni che vengono da stili diversi. Un’operazione non nostalgica ma quanto mai attuale, una rielaborazione di contenuti ottenuta attraverso la pulizia e lo stile propri di antoniolupi, la cura maniacale dei dettagli, l’eccellenza delle lavorazioni e dei materiali utilizzati.

L’ultima collezione riparte dall’inizio, dai primi passi della azienda di Antonio; ILBAGNO porta il segno della continuità nell’innovazione, la coerenza della visione, l’amore per il bello e ben fatto.



## 7 - L'uomo al centro di tutto

*“Siamo orgogliosi di essere un'azienda 100% Made in Italy che esporta molto all'estero. Vogliamo consolidare e rafforzare questa vocazione, guardare lontano sapendo che Stabbia e la Toscana saranno sempre la nostra casa, perché qui siamo nati e cresciuti e solo restando qui possiamo arrivare altrove”.*

*“Oggi il mercato estero è l'unica salvezza per aziende come la nostra. Ma noi non vogliamo abbandonare l'Italia, perché è solo lavorando qui che possiamo mantenere un livello qualitativo così alto da esportare in tutto il mondo”. È questa in estrema sintesi la strategia di un'azienda che vuole guardare lontano, affrontare nuove sfide, esplorare nuovi mercati senza dimenticare da dove viene, senza trascurare il proprio territorio, le proprie origini, la propria cultura. Dall'Italia antoniolupi vuole continuare a portare il bagno sartoriale nel mondo, perché il suo essere 100% Made in Italy è oggi garanzia di creatività, innovazione e stile. Oggi antoniolupi è una realtà con circa 80 addetti, presente in 52 paesi con showroom monomarca o tramite distributori e ha chiuso il 2013 con un fatturato di 26 milioni di euro (+7%) di cui il 30% fatto in Italia e il 70% all'estero. Una vocazione internazionale che nasce da lontano, dalla voglia di Andrea, ma prima di Antonio, di esplorare nuovi mondi, di andare lontano. “Abbiamo sempre guardato oltreconfine e dal 2006 abbiamo iniziato a presidiare le fiere all'estero con ottimi risultati. Siamo riusciti a portare il nostro stile in Europa e in America, ora vogliamo arrivare altrove, a partire dall'Asia”.*

Nord Europa, Belgio, Germania, Olanda, Svizzera, Francia e Russia sono i mercati più maturi che danno i migliori risultati, poi gli Stati Uniti, con gli showroom di Chicago e Miami che stanno dando grande soddisfazione. Una politica di espansione che strizza l'occhio anche ai grandi progetti internazionali. Il settore contract è per l'azienda un'opportunità importante, sia per l'ampiezza della gamma e delle proposte, sia per la capacità di dialogare con i progettisti sin dalle prime fasi del progetto. Molte collezioni di antoniolupi si inseriscono al meglio in ambienti dal gusto contemporaneo, dialogando con lo spazio che li ospita per valorizzarne i tratti salienti. In molti casi, per ottenere un risultato ottimale, è necessario pensare a queste soluzioni in fase di cantiere per poter ottenere una perfetta integrazione tra elemento e superficie, tra dettaglio e immagine complessiva dello spazio. All'interno di grandi progetti contract antoniolupi può garantire oltre alla qualità del prodotto un servizio all'altezza sotto il profilo della gestione della commessa, del livello di customizzazione dei prodotti ma anche delle tempistiche di consegna. Le tipologie di prodotto si sono nel tempo moltiplicate, alla ricerca di un total bathroom che si è presto allargato anche ad altri ambienti della casa. Antonioplupi non si è fermata infatti all'ambiente bagno, ma dopo aver indagato anche altri temi e aver aperto la strada a quella che si chiama brand extension, allo scorso salone ha fatto il grande salto. Lo ha fatto a modo suo, con il proprio stile, “gettando il cuore oltre l'ostacolo” ma con tanta consapevolezza e coerenza proprie della sua storia e del suo nome. Lo ha fatto, come sempre partendo dalle idee, dal segno, dalla visione. Il progetto LACUCINA sarà uno degli asset su cui si concentrerà l'attività dell'azienda nel prossimo futuro, perché il bagno rimarrà l'ambiente d'elezione di antoniolupi, ma i suoi confini si allargheranno, contamineranno altri ambienti, diventeranno cerniere e non divisioni. “Nella moda avviene spesso che un brand di successo proponga abiti ma anche borse, occhiali e scarpe, tutte con lo stesso stile e con la stessa impronta identitaria. Noi vogliamo che i nostri clienti, oltre al bagno abbiano la possibilità di avere in casa anche un camino o una cucina firmati antoniolupi”. Idee chiare, progetti ambiziosi, proposte integrate che tornano a strizzare l'occhio al settore contract, ma non solo: “Se presenti un bagno dalla forte personalità, con uno stile ricercato e un'alta possibilità di personalizzazione, gli architetti ti chiedono linee coerenti dello stesso brand anche per la cucina, il living o le camere. Più la gamma è completa maggiore è l'interesse a promuovere il marchio da parte dei progettisti”. Andrea Lupi e i suoi fratelli sanno che l'affermazione di un brand passa da scelte importanti, da strategie commerciali e distributive, da operazioni di marketing e di comunicazione, da attività di promozione e di diffusione capillare dei prodotti. Ma sanno soprattutto che al centro di tutto rimane il progetto, che il “sacro fuoco” delle idee non deve mai spegnersi, che i protagonisti del successo, come nella vita, rimangono l'uomo e la sua terra. Una terra che va amata e rispettata, attraverso un approccio sostenibile vero, concreto, che parte da materie prime riciclabili e certificate, passa dall'utilizzo, ad esempio, di vernici all'acqua, per arrivare alla divisione rigorosa degli scarti di produzione. Un amore per la terra e più in generale per l'ambiente che ci ospita, che non è un'imposizione da subire ma un atteggiamento naturale per chi con il territorio ha sempre avuto un rapporto privilegiato, per chi lo conosce fin da bambino, per chi lo ha vissuto intensamente e ancor più intensamente lo vuole custodire per le generazioni future. Perché, come conclude Andrea, al centro di tutto rimane sempre l'uomo: “Lavoriamo ogni giorno con passione perché il bagno e la casa del futuro diventino lo spazio dell'esperienza. Uno spazio sartoriale, su misura per anima e corpo, perché l'uomo è al centro di ogni nostro progetto”.

## 8 - Ascoltare, approfondire, agire: “essere” il futuro

*“Ci nutriamo di innovazione. Stare fermi è un delitto ed è il modo più sbagliato per gestire un'azienda. Siamo alla ricerca continua di spunti, idee, contaminazioni. Il nostro obiettivo non è seguire l'evoluzione delle mode e delle tendenze del design, bensì anticiparle. Mi piacerebbe molto essere rincorso”.*

L'innovazione è insita nel dna di antoniolupi. È sempre stata presente fin dalle origini con la vetreria di Antonio e lo è ancor più da quando i figli guidano l'azienda. Un'innovazione a 360°, sia per lo sviluppo dei prodotti, sia per lavorazione dei materiali, ma anche per le modalità di esposizione delle collezioni o per la forte identità degli spazi aziendali. Un'innovazione diffusa, trasversale, che interessa tutti e tutte le operazioni svolte in azienda, perché ciascuno si senta coinvolto nel processo di crescita complessiva, perché a ognuno sia data la possibilità di migliorare e migliorarsi.

Nel corso degli anni sono stati numerosi i picchi di altissimo livello in cui la capacità propositiva dell'azienda è esplosa in collezioni e progetti davvero unici. Ma in ogni progetto, in ogni racconto, i passi in avanti sono continui, le esperienze maturate sfociano in progressi tecnici o produttivi, le lavorazioni sui materiali, anche inediti, raggiungono punte d'eccellenza.

Il 2002 può essere indicato come l'anno della svolta sotto questo aspetto. È infatti di quell'anno Collection 2002, la prima collezione di arredo bagno interamente realizzata in Corian®. È l'emblema dell'approccio di Andrea nei confronti della ricerca; una ricerca non fine a sé stessa ma funzionale, un continuo interrogarsi sulle potenzialità dei materiali e sulla loro reale capacità di esprimere al meglio l'idea che sta dietro al progetto: “Siamo stati i primi a realizzare una collezione completamente in Corian®. Pur amando molto la ceramica, perché è un materiale che viene dalla terra, mi ero già reso conto dei suoi numerosi limiti. I materiali si erano evoluti, la ceramica, per le sue caratteristiche intrinseche, non permetteva certi tipi di lavorazione. Noi avevamo bisogno d'altro, avevo capito che il nostro approccio sartoriale avrebbe potuto concretizzarsi al meglio solo grazie ad un materiale nuovo, plasmabile in qualsiasi forma. Con Nevio Tellatin lavorammo molto sulle lastre di Corian® per dare forma alla Collezione 2002, una serie completa di lavabo, piatto doccia e vasca che segnò un grande momento di svolta nel settore”.

Per molti aspetti non si è trattato di un'operazione semplice. Le incertezze erano molte, le condizioni nuove da valutare non facevano stare tranquilli, ma Andrea aveva visto lontano e antoniolupi si buttò con tutte le energie in questa avventura. “Avevamo dubbi più che leciti sui costi e sulla fattibilità dell'operazione. Inoltre lavorare sul su misura voleva dire ribaltare completamente l'approccio della produzione. Il Corian® era un materiale molto caro, difficile da lavorare e da plasmare, nato per altri scopi e per noi era una prima volta. Il rischio era quello di fare oggetti belli ma troppo costosi e poco funzionali. Fortunatamente non fu così. Il lavabo Slot è uno degli emblemi della collezione ed è diventato uno degli oggetti identificativi di antoniolupi perché elimina alla vista tutte le componenti funzionali ma in realtà funziona benissimo!”.

Questo progetto simboleggia come più in generale la ricerca sia indispensabile in ogni progetto, anche quello più semplice, che sembrerebbe scontato. “Per me la vera innovazione è anche questa. Avere in mente un'idea che si traduce in progetto e poi prodotto solo grazie alla ricerca del materiale giusto per quella specifica proposta. Senza quel materiale il progetto non potrebbe compiersi nella sua totalità”. Ad esempio senza il Corian® e la sua capacità di assumere qualsiasi forma non sarebbe stato possibile realizzare piatti doccia su misura o risolvere i frequenti problemi del fuori squadra, ma nemmeno ottenere superfici perfette, lisce, morbide al tatto, invitanti.

Non necessariamente l'innovazione deve coincidere con l'utilizzo di un materiale nuovo o artificiale. Quando, infatti, nel 2003 prende forma il progetto Materia di Carlo Colombo, Andrea e l'azienda non hanno nessun problema a tornare alle origini, nessuna paura nel tornare a lavorare la pietra, con le sue specificità, le sue caratteristiche sempre diverse, le difficoltà nella lavorazione. “In quel progetto i marmi e le pietre erano il materiale ideale per dare forma alle linee morbide disegnate da Colombo, erano perfette per consolidare l'unicità degli elementi, per renderlo unico e irripetibile. E pietra fu”. Sarà una collezione delle origini, perché oltre alle pietre saranno protagonisti alcuni straordinari oggetti in vetro soffiato tipici delle lavorazioni artigianali del territorio, ma anche dell'innovazione, perché sui lavabi e sulle vasche risplenderanno per la prima volta rubinetti a sezione rettangolare.

Il 2006 sarà un altro anno decisivo per l'attività dell'azienda e in particolare per la produzione dei mobili, che ancor oggi occupa una quota significativa di tutta l'attività dell'azienda. Proprio i mobili e i contenitori sono infatti gli assoluti protagonisti della collezione Panta Rei, sempre a firma di Carlo Colombo. “È stato l'inizio di tutte le innovazioni che abbiamo apportato nel comparto dei mobili. Il livello qualitativo raggiunto con Panta Rei è diventato uno standard per tutte le nostre collezioni”. Per la prima volta in quest'occasione, antoniolupi presentò contenitori, sottotop, mobili, o vani a giorno con profili a 45° che, oltre a snellire in maniera significativa anche le sezioni a forte spessore, contribuiva

a migliorare la qualità estetica complessiva dell'insieme. Da quel momento tutti i mobili della gamma sarebbero stati prodotti con taglio a 45° mentre la perfezione raggiunta con Panta Rei nella laccatura e nell'impiallacciatura diventerà poi il parametro di riferimento per ogni prodotto.

Del 2008 abbiamo più volte parlato perché l'introduzione del fuoco nella stanza da bagno, fu una vera e propria rivoluzione. Da "Il Canto del Fuoco" in poi tutte le aziende iniziarono a proporre camini a bioetanolo o soluzioni simili per "riscaldare" l'atmosfera e aumentare la sensazione di comfort e benessere. *"Con il fuoco abbiamo trovato un amico silenzioso che ci accompagna nei momenti di relax, una presenza discreta ma evidente, un segno leggero ma emozionante"*. Appena raggiunto il risultato ad Andrea i biocamini già non bastavano più, voleva un camino "vero" a legna, dall'immagine forte ma allo stesso tempo pulita ed essenziale, che dialogasse con lo spazio architettonico lasciando al fuoco il ruolo da protagonista. Nel 2010 nasce Skema, di Mario Ferrarini, il camino a legna modulare che parte dalla bocca del camino e per aggregazione di elementi diversi (braciare, porta legna, vani giorno...) può svilupparsi idealmente all'infinito. Un progetto formale ma soprattutto tecnico, nel quale la competenza del maestro fumista Massimo Pistolesi è stata fondamentale per sviluppare la macchina e perfezionare tutte le funzionalità dell'elemento. Competenza e amore per un elemento che, come ricorda Pistolesi citando Eraclito, *"È sempre vivo, in continuo movimento; è in ogni momento diverso dal momento precedente, ma allo stesso tempo sempre uguale a sé stesso"*. Una metafora dell'esistenza in continuo mutamento e sempre variabile ma anche una definizione che aderisce perfettamente all'attività di antoniolupi, alla capacità di essere sempre in movimento e di cambiare direzione pur rimanendo sempre sé stessi.

Il fuoco non fu l'unico elemento "atipico" che contribuì a completare, assieme ovviamente agli elementi essenziali come sanitari, lavabi e vasche, l'offerta di un total look ricco di dettagli e accessori. Sempre nel 2008 furono introdotti ad esempio i tappeti in cuoio rigenerato di Riccardo Fattori, complementi importanti con decori semplici o motivi più ricercati, capaci di arricchire e contaminare con nuovi significati ed eleganti grafismi, uno stile comunque essenziale e misurato. Non poteva mancare una proposta anche per l'outdoor e nel 2012 ecco Oio di Michel Boucquillon, il lavabo da terra economico, facile, glamour, da spostare e portare dove vuoi. Nuovo progetto e nuovo materiale, come spesso accade per antoniolupi: il Polietilene, stampato in rotazionale, super colorato, ecosostenibile e volendo anche traslucido per ospitare al suo interno una fonte luminosa e trasformarlo in un oggetto magico di forte impatto.

Se l'ambiente bagno sartoriale può dirsi completato, con un'articolata proposta di collezioni di impronta diversa e un corredo di complementi versatili e di alta qualità, il 2013 diventa il momento giusto per lavorare anche sulle superfici, per offrire ai propri clienti una possibilità di personalizzazione dello spazio non solo attraverso gli "oggetti" che vi trovano posto ma anche attraverso gli elementi architettonici che lo compongono. Dalla ricerca di Pietro Gaeta sulla decorazione nascono così gli Affreschi, rivestimenti murari che "vestono" le superfici, per creare uno sfondo ideale per sanitari e protagonisti della stanza, una quinta scenica ricercata e vibrante che possa arricchire il racconto di una nuova storia. Un progetto futuristico che nasce dal passato, da una tecnica antica, quella dell'affresco, reinterpretata in chiave contemporanea; una stratificazione di immagini, una sovrapposizione di texture e stili, una possibilità infinita di personalizzazione grazie a una carta transfer che consente di trasferire qualsiasi immagine direttamente sull'intonaco. Un nuova sfida vinta *"In soli sei mesi abbiamo messo a punto un progetto che era lontano dalle nostre corde e dal nostro stile"*.

Ora abbiamo davvero tutto, anzi no. Manca un elemento tecnico ma che oggi è diventato anche oggetto d'arredo, una fonte di calore ma non solo, un elemento la cui personalità può cambiare volto all'intero ambiente: una volta si chiamava calorifero, ora si chiama radiatore. BIT, di Brian Sironi, è il primo progetto di termoarredo di antoniolupi. Sotto l'aspetto formale le lievi sporgenze in sequenza ritmica, determinano un leggero gioco di ombre che lo rendono scultoreo, una sorta di bassorilievo contemporaneo. Realizzato interamente in alluminio e per questo riciclabile al 100%, BIT è un radiatore personalizzabile sia nei colori che nelle dimensioni e può avere un funzionamento elettrico, ad acqua o anche misto.

Non manca più nulla, ci sono tutti gli elementi per avere un bagno interamente firmato antoniolupi, Andrea e i suoi possono dirsi orgogliosamente soddisfatti. Ma non è il momento di fermarsi, per la verità non è mai il momento di fermarsi. Andrea esplora, assorbe, ricostruisce, sogna...ed ecco la nuova sfida, l'ennesima: la cucina. O meglio LACUCINA. *"Incontrai Marco Casamonti al nostro stand durante il Cersaie del 2012. Mi chiese se fossi interessato ad allargare il campo della nostra attività anche fuori dal bagno. In realtà la cucina era nella mia testa da parecchio tempo e come sempre risposi che se mi avesse sottoposto un progetto convincente perché no, ci avrei provato. Mi mostrò su un Ipad (come sono cambiati i tempi!) un rendering con quella mensola a C che mi colpì subito. Capii che eravamo ancora molto lontani da un progetto e che la strada sarebbe stata molto lunga ma quel segno, come spesso accade, mi convinse subito. Accettai la sfida. Per me si fa, risposi e dopo due anni di intenso*

*lavoro eccoci qua con LACUCINA"*.

È nato un progetto dal forte impatto formale, che mette al centro il cibo e la preparazione degli alimenti attraverso un piano di lavoro continuo in Corian®, realizzabile su misura, sul quale troveranno posto alimenti, accessori e utensili da cucina. Una grande mensola che si richiude su se stessa, un elemento fondante dalla forte identità attorno al quale costruire la propria cucina.

L'azienda si è mossa su un terreno difficile, in un ambiente diverso da quello d'elezione, ma l'ha fatto come sempre con competenza e coraggio, valutando attentamente tutti gli aspetti. Andrea ha cercato di carpire i segreti, li ha fatti propri, ha digerito e rielaborato il progetto per renderlo attuabile e lo ha portato a compimento, ancora una volta...tutto questo si chiama innovazione!











## 9 - Etica ed estetica del saper fare

*“Lavoriamo con persone che fanno cose fantastiche, artigiani che sanno trasformare la materia come artisti rinascimentali, che la conoscono, la curano, la valorizzano. Dobbiamo solo aiutarli a far sì che non smettano mai di amarla”.*

Una fitta e articolata rete composta da oltre 200 artigiani che lavorano con competenza e maestria la materia, un bacino unico di storie e creatività presenti sul territorio che permettono di affrontare qualsiasi sfida progettuale, di trovare il modo giusto per interpretare le esigenze di progettisti e clienti, di soddisfare le richieste dell'azienda. A sottolineare il radicamento sul territorio di antoniolupi è la volontà di Andrea di coinvolgere sempre le maestranze locali, ciascuno secondo le proprie competenze, per creare progetti unici e irripetibili, oggetti carichi di significato, di valore e di cultura: *“È nostro compito preservare questo patrimonio unico di conoscenze, dobbiamo far sì che all'interno delle nostre proposte, pur in un'estetica contemporanea e minimale com'è nel nostro stile, rimanga forte l'impronta artigianale. Antoniolumi deve continuamente dimostrare la capacità produttiva di un'azienda industriale mantenendo la possibilità di personalizzazione che solo una lavorazione manuale può dare”.* L'obiettivo è quello di reinterpretare la tradizione, di riattualizzare la storia, di trasmettere quella cultura della materia e del “saper fare” che abbiamo perso, che troppe volte abbiamo messo da parte alla ricerca dell'effimero, della tecnologia a tutti i costi, ma che oggi dobbiamo necessariamente ritrovare. *“Spesso la manualità locale è predominante sul progetto, solo così possiamo esprimere fino in fondo la nostra anima sartoriale e mantenere alta la qualità del prodotto”.*

Il filosofo britannico John Locke (1632-1704) affermava *“La conoscenza di nessun uomo potrà mai andare oltre la sua esperienza”.* Valorizzare queste risorse vuol dire rispettare il territorio, significa avere coscienza di quanto sia importante mantenere viva la nostra storia, ma vuol dire anche sapere che dalla rilettura del passato e dei suoi significati possono nascere spunti e idee per il futuro, dalla conoscenza di chi eravamo può nascere la consapevolezza di chi siamo e la speranza di come potremo essere.

Materiali unici come la pietra, i marmi, gli alabastrini, ricavati da blocchi delle vicine cave di Carrara, vengono scelti personalmente da Andrea e poi lavorati con sapienza per estrarne l'essenza, per togliere il superfluo e riportare in luce l'identità della materia. Solo così, lavorando per sottrazione come gli scultori, è possibile dare vita a collezioni esclusive, a superfici da toccare a forme sinuose e avvolgenti perfettamente levigate. Impreziosire il proprio bagno con un pezzo della collezione Materia o Talamo (anche se le provenienze delle pietre sono diverse), vuol dire poter disporre di un pezzo di storia, vuol dire immergersi in un racconto millenario, vuol dire confrontarsi con la creazione del mondo. Materiali così importanti richiedono competenze specifiche e lavorazioni artigianali non riproducibili su scala industriale, se si vuole ottenere un livello qualitativo d'eccellenza.

Il legame tra antoniolumi e il territorio si rafforza ulteriormente quando si parla del materiale d'eccellenza dell'azienda, quello da cui tutto ebbe inizio: il vetro. Un destino scritto nelle origini, un rapporto, quello delle storiche vetrerie di Montelupo che arriva da lontano, quando proprio da queste fabbriche uscivano i fiaschi per il Chianti e la famiglia di Mara, moglie di Antonio Lupi, lavorava come impagliatrice per rivestirli. Un rapporto che non si è mai interrotto e che ha ripreso vigore con le collezioni di lavabi in vetro soffiato realizzati dai più bravi artigiani del territorio.

Per ogni materiale ci sarebbe una storia da raccontare (come dimenticare la tradizione della maiolica rinascimentale, sempre a Montelupo), per ogni collezione qualche aneddoto potrebbe spiegare come si possa arrivare a un' eccellenza del dettaglio senza eguali. Dai tappeti e dagli oggetti in cuoio che l'azienda ha inserito nella propria offerta e che nascono dalle numerose concerie e aziende di trasformazione del territorio, alla lavorazione del legno, oggi tornata prepotentemente al centro dell'attenzione con l'esclusiva eleganza e il gusto romantico della collezione ILBAGNO.

La crescita dell'azienda passa anche dal continuo confronto con questi artisti sconosciuti, con questi uomini che con pazienza e costanza trasformano le idee in opere d'arte; maestri inimitabili ma anche interlocutori affidabili, che con coerenza e impegno collaborano con l'azienda per continuare a migliorarsi e a crescere insieme, perché come ricorda Patrizia *“Il successo di antoniolumi non è solo il successo di noi fratelli, ma di tutte le persone che hanno contribuito a fare grande questa azienda”.*







## 10 - I dettagli che fanno la differenza

*“Abbiamo lavorato con tanti materiali, tradizionali, innovativi, ciascuno con le proprie caratteristiche. Solo il cristallo è eterno, inscalfibile, resistente, inattaccabile. Mio padre iniziò da lì e, anche se oggi il vetro è stato spesso messo da parte dal design contemporaneo, noi non ci dimentichiamo della nostra anima più pura e trasparente”* Nello Lupi

*“Dio è nei dettagli”* diceva Ludwig Mies Van Der Rohe, uno degli assoluti protagonisti del Movimento Moderno. Il dettaglio per antoniolupi è l'elemento che dà valore al tutto, è l'unica garanzia di qualità complessiva di un prodotto, è il metro di valutazione del livello raggiunto dai processi produttivi, il parametro di riferimento dell'eccellenza. Solo analizzando i dettagli si vedono le differenze tra grandi e piccole aziende, tra prodotti innovativi e proposte poco significative, tra progetti che determineranno una tendenza e altri che la seguiranno.

La qualità e l'attenzione ai dettagli sono i fili conduttori di tutte le fasi del processo produttivo di antoniolupi. Dalle materie prime al prodotto finito, il ciclo prevede una sequenza di lavorazioni meccaniche o manuali, dall'alto contenuto tecnologico o di grande spessore umano. In tutte l'invariante è la perfezione del risultato e il massimo livello qualitativo di ogni prodotto.

Da antoniolupi si lavora just in time, si produce solo su ordine e non esistono scorte di magazzino. Ogni elemento che esce dalla fabbrica risponde a specifiche richieste di progetto, è stato pensato per essere inserito in quella particolare ambientazione, è stato prodotto per soddisfare le richieste del cliente specifico. La grande possibilità di personalizzazione legata a materiali, finiture e colori, permette infatti di sviluppare un'idea di bagno completamente su misura per il cliente, sia dal punto di vista dimensionale, che formale.

Grande attenzione viene dedicata dall'azienda nella scelta dei fornitori, per la maggior parte italiani, in gran parte toscani e tutti di altissima qualità. A partire dalle ante e dalle strutture dei mobili e dei contenitori, tutti realizzati in multistrato di betulla e accessoriati con sistemi e componentistica di massimo livello, per finire con il vetro, acquistato in lastre di grosse dimensioni. Senza dimenticare i marmi e le pietre, scelti dalle vicine cave di Carrara o il Corian®, ormai utilizzato da tempo con un livello di perfezione assoluta.

La produzione di mobili per l'arredo bagno rappresenta una quota importante dell'impegno complessivo dell'azienda e gran parte dello stabilimento è ad essa dedicata: dalla preparazione della struttura, al taglio delle ante o dei frontali (lavorazione a barre), dalla verniciatura al montaggio. Ogni operazione viene svolta seguendo le direttive del progetto, per rendere ogni elemento esclusivo e perfettamente rispondente alle richieste. Dai pensili ai sottolavabi, dalle colonne ai cassetti di qualsiasi forma, colore e finitura: questi elementi sono chiamati a dialogare con i protagonisti dello spazio (lavabi, sanitari, vasche) e per questo debbono poter garantire un livello estetico e funzionale ad essi equiparabile. La lavorazione a 45° di ogni profilo, consente di dar vita a dettagli raffinati e a incastri perfetti del cassonetto, che viene poi equipaggiato con cerniere, supporti, guide e tutto quanto necessario allo svolgimento della funzione prevista. Attualmente le richieste del mercato e le preferenze dei clienti attestano all'80% la produzione di mobili laccati. I pannelli di legno vengono perciò tagliati, sagomati, forati e dimensionati come da disegno prima di essere portati alla fase di verniciatura che proprio per questo riveste una grande importanza ed è uno dei fiori all'occhiello dell'azienda. Ogni pezzo viene verniciato manualmente a spruzzo in cabina con vernici all'acqua, ecologiche e prive di sostanze tossiche. Un'operazione complessa, eseguita da tecnici esperti, che prevede due mani di poliesteri interno e due mani di poliesteri esterno ai quali si aggiungono, una volta che il pezzo è asciugato, due mani di pigmento lucido o opaco. Tutte le miscele vengono preparate internamente dall'azienda secondo campione o in base alle diverse esigenze del cliente.

Oggi la gamma di antoniolupi prevede 55 colori opachi o lucidi e la flessibilità richiesta dalla produzione sartoriale può richiedere anche 10/15 cambi colore al giorno che devono avvenire con la massima semplicità e nel minor tempo possibile. Dopo 12 ore in camera di essiccazione ad umidità e temperatura controllate, la superficie viene carteggiata per eliminare le imperfezioni o la vernice in eccesso. Qualora venga richiesto si passa poi alla lucidatura che consente di ottenere una superficie a specchio perfetta, grazie alla manualità degli operatori e alla loro esperienza nel capire le differenti rese estetiche di ogni colore. Un risultato eccellente, una perfezione assoluta senza eguali, un livello qualitativo ricercato anche nei mobili in essenza. In questo caso antoniolupi dedica straordinaria attenzione all'impiallacciatura, con soluzioni che hanno l'obiettivo di valorizzare al massimo i disegni naturali e la texture inimitabile del legno. La disposizione orizzontale delle venature disposte a correre, comporta necessariamente difficoltà maggiori nella lavorazione, ma assicura un risultato unico ed esclusivo. Il volume del mobile, compresi i frontali e le ante, viene avvolto da una pelle solcata da segni irregolari che si rincorrono senza soluzione di continuità.

L'altro grande protagonista della produzione di antoniolupi è la vetreria. Un luogo d'affezione, un materiale d'elezione, una lavorazione simbolo dell'azienda perché è proprio dal vetro che tutto ebbe inizio. Il materiale è stato un po' messo da parte dall'interior design contemporaneo, forse per la sua difficoltà di gestione, lettura, interpretazione. Per antoniolupi non è così. *“Col vetro abbiamo sempre lavorato e continueremo a farlo, rispettandone identità caratteristiche e peculiarità”* racconta Andrea. Come nelle ultime collezioni, nelle quali preziosi contenitori affiancano lavabi e sanitari, con straordinaria leggerezza ed eleganza.

Ci si accorge dell'importanza del vetro quando si varca il portone d'ingresso dello stabilimento a esso dedicato. Si sviluppa automaticamente una forma di rispetto e attenzione maggiore, quasi a non voler contaminare l'assoluta purezza del materiale, la delicatezza delle lavorazioni, la perfezione delle superfici, l'esclusività dei trattamenti. Dai lavabi integrati nel top agli specchi, dai lavabi da appoggio ai contenitori: tutti i prodotti nascono dalla lavorazione delle lastre che arrivano da fornitori italiani ed europei. Le lastre hanno differenti dimensioni e spessori in base alla tipologia dell'elemento da realizzare: saranno più sottili per gli specchi, di spessore maggiore per i piani d'appoggio e per i lavabi tutto vetro. Più semplice, almeno apparentemente, il processo richiesto per ottenere specchi dalle linee pulite e lineari: alla lastra in vetro tagliata nelle dimensioni corrette, viene assemblato manualmente il telaio metallico nella forma desiderata, all'interno del quale, se richiesto, vengono alloggiati le parti elettriche per la retroilluminazione o per l'illuminazione perimetrale.

Più complesse le operazioni necessarie per realizzare i lavabi integrati nel piano senza soluzione di continuità. Speciali forni nei quali è alloggiata una matrice sagomata, raggiungono una temperatura elevata per rendere malleabile il vetro provocare, nella parte centrale della lastra, la depressione che darà forma al lavabo. Un'operazione molto complessa nel quale devono essere costantemente monitorate le temperature di fusione e raffreddamento per evitare sollecitazioni troppo elevate che potrebbero portare a tensioni nel materiale superiori a quelle previste, con conseguente rottura.

Tutti i pezzi ottenuti da vetreria, falegnameria e montaggio vengono accuratamente imballati in base alla tipologia di trasporto e alle richieste del cliente, per evitare danneggiamenti e rotture. Ogni bancale corrisponde ad un ordine specifico e ospita tutto ciò che è previsto dalla commessa; una volta completato in tutte le sue parti viene immediatamente spedito.

Corian®, Ceramilux®, Cristalplant®, marmo, pietra, vetro e legno: un abaco di materiali naturali o artificiali, texture, superfici e colori che danno vita a infinite combinazioni possibili, valorizzate dalla creatività e dalla capacità unica di lavorare la materia di antoniolupi.









## **Non diamolo per scontato...**

*“Ci sono delle particolarità nella nostra produzione che noi in azienda diamo per scontate, perché lavoriamo così da sempre. Ci hanno fatto notare che dovremmo evidenziarle per far capire ulteriormente la nostra diversità, la nostra cura del prodotto, la specificità di certe lavorazioni. Noi abbiamo sempre pensato che un prodotto di alta qualità debba essere per forza fatto così e ogni volta che scopriamo il modo di migliorarlo lo facciamo istantaneamente perché questa è la nostra filosofia, non sappiamo lavorare in altro modo e non ci accontentiamo mai: quello che non si vede per noi è più importante di quello che tutti possono vedere”.*

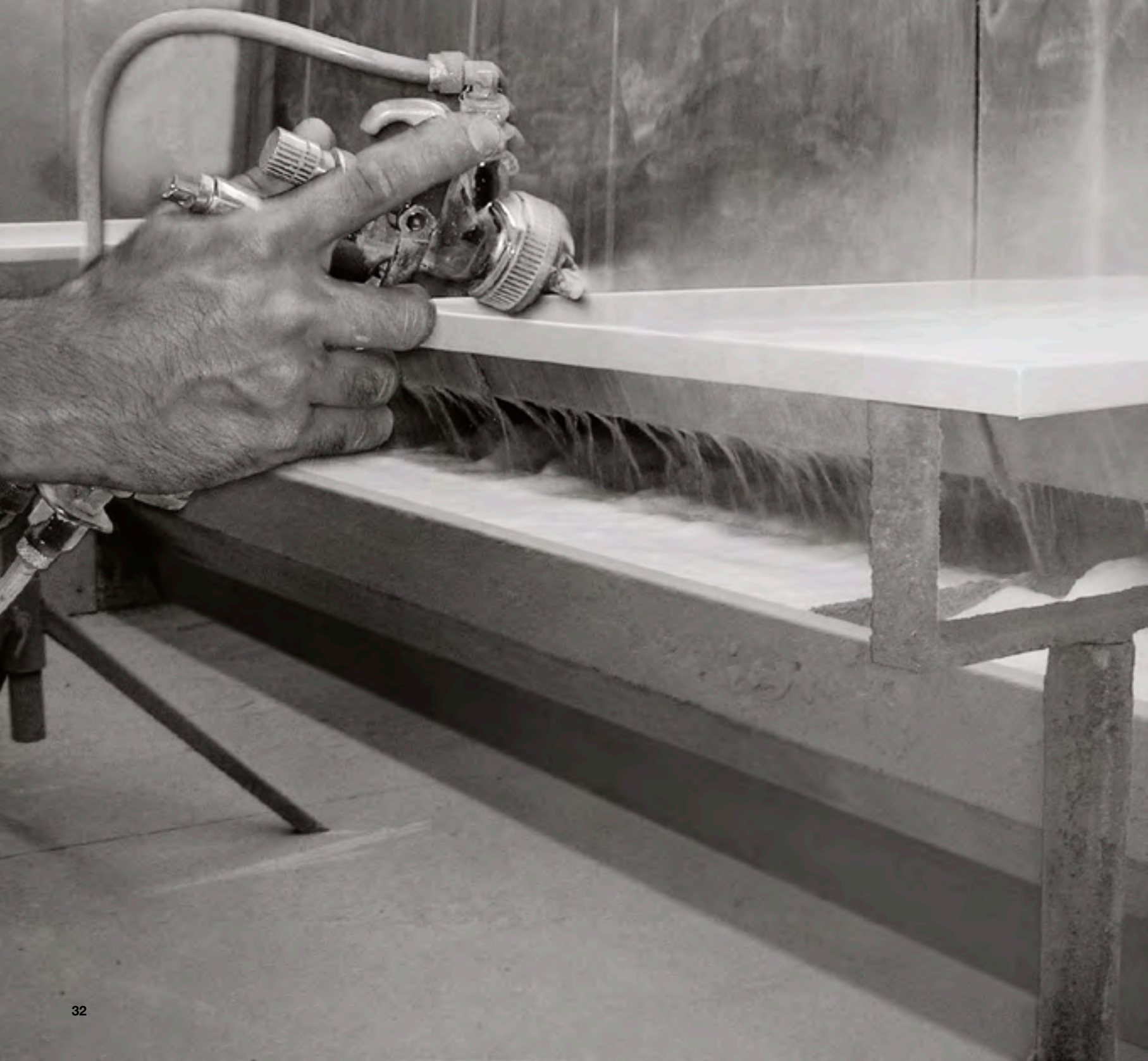





8 strati di  
verniciatura  
8 coats of  
paint

1 polyester  
2 polyester  
3 vernice/paint  
4 vernice/paint

1 polyester  
2 polyester  
3 vernice/paint  
4 vernice/paint

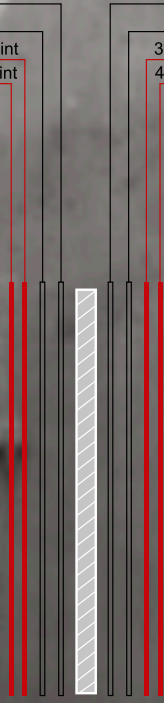



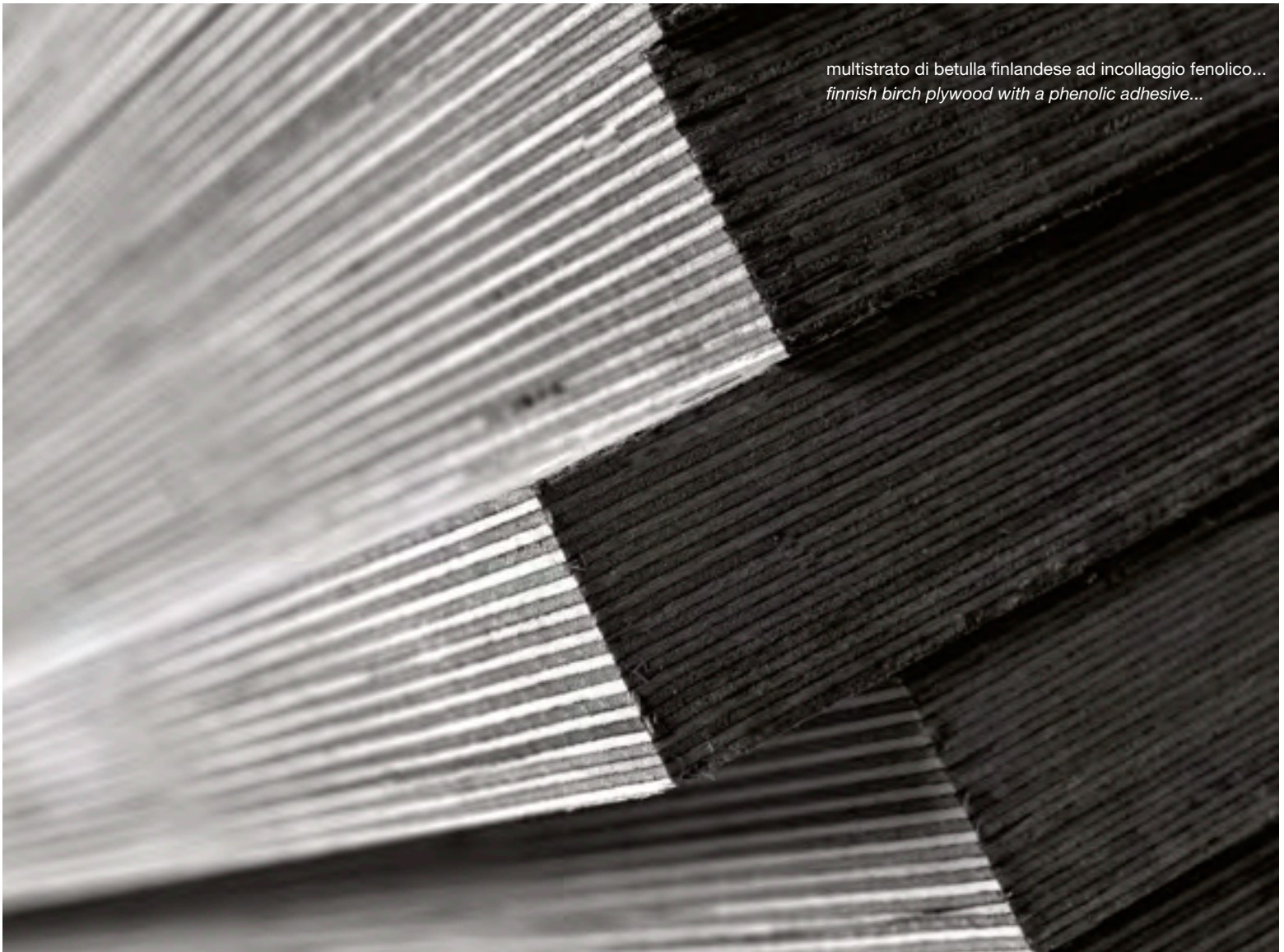

multistrato di betulla finlandese ad incollaggio fenolico...  
*finnish birch plywood with a phenolic adhesive...*

...impiallacciatura in essenza di legno di 6 decimi...  
*...6 tenths wood essence veneer...*



...piani da 18/36 mm in multistrato...  
*...18/36 mm plywood tops...*







su misura per ogni cliente  
*made to order for each and every client*



cassetti a chiusura ammortizzata con portata di 30 kg  
drawers with shock-absorbing closing system with 30 kg of capacity





cerniere che sopportano 20 kg di peso...  
*hinges that support up to 20 kg of weight...*





## 11 - Gli altri siamo noi

*“Senza i nostri collaboratori non saremmo arrivati fin qui, senza il sacrificio e l’impegno di tutti non avremmo raggiunto questi risultati, senza la mano dell’operaio, l’idea del creativo e la testa di chi deve far tornare i conti non avremmo ottenuto nulla. Perché il nostro è un gioco di squadra e a noi piace che tutti si sentano protagonisti”*

Un’azienda ottiene risultati solo se tutti remano dalla stessa parte; un gruppo di lavoro cresce e si consolida solo se ogni suo componente si sente partecipe dei successi conseguiti (ma anche degli insuccessi). Una grande realtà familiare come antoniolupi funziona quando c’è affiatamento tra gruppo dirigente e dipendenti, quando c’è un rapporto sano e costruttivo tra management e lavoratori, tra operai e creativi, tra amministrazione e rete commerciale...insomma, quando tutti concorrono al bene dell’azienda e da questo bene traggono soddisfazioni personali.

La storia di antoniolupi è un racconto fatto di condivisione, di strade percorse insieme, di confronti schietti e sinceri, di rapporti che si sono evoluti e consolidati nel tempo, di fiducia reciproca e di crescita per tutti. La famiglia Lupi, che da sempre guida l’azienda, è stata protagonista di tutte le vicende più importanti. Una famiglia allargata, perché oltre ai figli di Antonio furono altri i coprotagonisti di questa avventura, come racconta Andrea *“Mio zio Piero, che già lavorava con il babbo nella Crystal Lupi Luxor, ci seguì fin da subito quando con i miei fratelli fondammo la Gilly di Lupi Patrizia. Fu un innesto decisivo per noi perché la sua grande esperienza come responsabile di produzione ci permise di impostare fin da subito l’azienda secondo i canoni di ordine, qualità e chiarezza, dei rapporti con i fornitori che ancora oggi sono condizioni imprescindibili della nostra attività”*.

Uomo di grande esperienza, Piero Giuntoli seguì fin da subito con entusiasmo, credendo totalmente nel nuovo progetto di Andrea, Nello e Patrizia. Con lo stesso entusiasmo trasferì le sue competenze alla nuova antoniolupi e, ancor oggi, contribuisce ai successi dell’azienda con la propria esperienza oltre a una straordinaria voglia di fare.

Un percorso analogo a quello di Enzo, marito di Patrizia, coinvolto anch’egli fin dagli esordi della Gilly a Fucecchio. Quando Andrea e Nello si dedicarono completamente a tutte le attività operative legate alla produzione delle prime collezioni, divenne necessario individuare un nuovo referente commerciale per la Toscana e la scelta ricadde sul cognato. Da lì un lungo sodalizio che dura tutt’ora, con nuove competenze e una professionalità che si è costruita nel tempo *“Enzo fu il primo a presentare al mercato le nostre nuove collezioni di arredo bagno. Partì, come avevo fatto io, dalla Toscana e oggi, dopo quasi trent’anni, è il nostro Direttore Commerciale, una figura cruciale nel panorama aziendale, un ruolo delicato che abbiamo deciso di affidare a uno di famiglia. Serviva qualcuno che conoscesse la nostra storia, che fosse coinvolto al 100% nel progetto, che condividesse le nostre idee e i nostri obiettivi e di Enzo ci potevamo fidare ciecamente”*. Oggi Enzo Giachi affianca gli agenti di zona in tutta Italia e lavora fianco a fianco con i clienti per soddisfare le loro richieste, attraverso la qualità e l’approccio sartoriale di antoniolupi.

Accanto a queste figure, che rientrano comunque nell’orbita familiare, gravitano anche una serie di collaboratori silenziosi, di operai insostituibili, di uomini e donne che hanno dato vita al brand affermato in tutto il mondo. Ogni singola attività e contributo sono essenziali per ottenere gli oggetti straordinari che oggi l’azienda produce. Ogni fase del processo merita attenzione, ogni aspetto deve essere seguito con professionalità e competenza. Proprio per questo Andrea ha strutturato un proprio team di collaboratori che si occupa della parte creativa. Dalla progettazione alla grafica, dagli allestimenti degli showroom a quelli degli stand fieristici, dallo sviluppo dei prodotti ai progetti speciali.

*“Tutti sono importanti perché in sintonia con l’azienda. Dovrei citarli tutti, ma prendo ad esempio Riccardo Fattori che collabora con me da oltre dieci anni per proporre un’immagine coordinata dell’azienda. Ma non solo, lavora sulla comunicazione, sul prodotto, sulla grafica, portando il suo contributo di creatività, il suo lavoro è importante per rendere visibili i valori, lo stile, il racconto, vorrei dire la poetica, di antoniolupi.”* E Riccardo cosa ne pensa? *“Lavorare con Andrea è molto stimolante, non siamo due caratteri facili, ma penso che in questi anni abbiamo raggiunto una buona sintonia e una comunione di intenti. Andrea è sempre in movimento, sempre alla ricerca di qualcosa di nuovo, di qualcosa di bello, diventa facile appassionarsi ad un progetto che cambia costantemente, per uno come me che mal sopporta la routine. Devo dire anche che sono molto facilitato nel mio lavoro, da un team di suoi collaboratori che sono un gruppo fantastico, che mi consente anche di fare “il poeta” dandomi manforte ogni volta che occorre. Per questo posso solo ringraziare Andrea e i suoi fratelli per aver pensato che il mio contributo potesse essere importante per la loro azienda e per avermi confermato la loro fiducia in tutti questi anni.”*









## 1 - A “tailor-made” service

*“Today the expression “tailor-made” is so common that I feel almost tired of talking about it. We started with a made-to-measure production and we reinforced this identity adding at the same time a rigorous industrial approach, made of certainty and reliability, respect for everyone’s work and for production lead-times. Service and products are equally important”.*

It’s well known that in a very competitive market, service ends up being one of the most important aspects in the process of selection and purchase of a product. Too often Italian companies have been blamed for not being reliable, for lack of organization or inveterate delays. The value of Italian design and in general of Made in Italy is recognized worldwide but this is no longer enough. Nobody doubts on the quality of our products but what is uncertain is what happens next, when the product is finished and ready to be shipped. The life of a product does not end with delivery but it is longer and with time, renovation, maintenance, replacement of spare parts might be required. Therefore the life cycle of the product has to be followed with the same care employed to produce it. At antoniolupi after-sale service and product are equally important. These are two complementary aspects, two sides of the same coin that cannot exist separately. Because of this, the company has always put many efforts in managing a perfect production process during which customer care has to remain unaltered: from order to made-to-measure production, from customized design to packing. A tested procedure where all passages must perform smoothly, especially when a company is producing to order and it needs to be able to face sudden peaks of orders without subtracting anything in quality of service. Production lead-times are 30 days for the Italian market and 40 days for export. It is a very short time for a production process that makes of attention to details and high quality its distinctive marks. It is a very short time especially when considering that often products are made-to-measure in terms of size, finish or color. When the product is finished, also the packing process requires particular scrutiny because claims regarding broken products due to transport are not so infrequent. In order to avoid any problem, antoniolupi produces a specific packing for each type of product and means of transport, reinforcing the packing in some cases with supports, wooden cases, or details that help operations of loading and discharge of goods. Service does not end with delivery but continues with a precise and punctual assistance in case of problems. Some products require a constant collaboration with the client, either as an end customer or a designer because they may require intervention when the installation is in progress and also when installation is finished. The client is for antoniolupi at the centre of the project and in order to offer a better consultancy from the early stages of the project, when possible, the company is putting all its efforts in distribution starting from its mono-brand showrooms. In these contexts it is possible to express the full potential of the company at the highest level because the showroom becomes a hub for architects, designers and end customers. It means getting in contact with people and propose unexpected solutions or limit mistakes due to lack of information or misunderstandings, or again eliminate prejudice. It is not easy to explain how a sink or a fireplace can be totally encased in a wall without showing how effectively this is possible. Antoniolumi mono-brand showrooms are welcoming and functional spaces, islands of relaxation in the chaotic city where it is possible to plunge into the antoniolupi’s total look but also places where people are willing to provide replies to solve a problem, to clarify a doubt, to support a design choice. With the grand-opening of the showroom in Milan, antoniolupi reinforces its brand identity in a field in which it is not easy to have a recognizable style. In the capital of design the home of antoniolupi is a place where it is possible to establish a privileged relationship, where people can take their time before making their choice and also be advised carefully. The showroom will be soon extended in order to offer a better service and a more complete display. Milano was only the starting point of a chain that rapidly developed and today sees other showrooms in Chicago, Miami, Monaco e Torino. A choice, that of the mono-brand showroom which does not forget about the traditional distribution which is composed of specialized shops displaying antoniolupi products in dedicated shop-in-shop areas. *“We are ready for new shop-in-shops if our business partners are willing to dedicate to antoniolupi 60%-70% of their shop”.* Communication and presence at fairs contribute to promote business. Antoniolumi brings into the world its way of interpreting and living the bathroom and do it with all means and possibilities, trying to take advantage of all opportunities, offering the maximum at every occasion. The service philosophy is to do better each time through continual self improvement to attain world class performance.

## 2 - 100% made in Tuscany

*“It’s important to contribute to our unique territory with its cultural heritage and its extraordinary beauty. We have to rediscover the value of our land, because quality is the only thing that can save our country and its companies”.*

Many ancient civilizations settled and developed along a river. Many companies also began near water because, water could move machines to start production. The valley of the river Arno represents a unique territory, a cradle of different ethnic groups, a heritage of knowledge handed down from one generation to another. The famous route Via Francigena passes through this valley and is characterized by gastronomic delights, wonderful landscapes, cultural and artistic masterpieces.

Before being Italian, Antoniolumi is a Tuscan company that represents a local patrimony, a melting pot of different elements who contribute to achieve the highest quality standards. Maybe due to the cultural environment or maybe to the passion and the obstinacy of local men and women does this territory represent a symbol of the true Made in Italy. The company belongs to a rich and difficult environment, with big potentialities but also with problems never solved. A landscape made of gorgeous hills, but also of extended unused areas, like the Fucecchio Marshes, the biggest internal Italian swampland with its 2000 hectares, where the history of Antonio Lupi began. Thanks to its strategic position and its particular morphology, the Marshes always played an important role in the development of different populations that lived in this part of Tuscany. During the Renaissance, for example, Cosimo de’ Medici ordered that the river Usciana be closed to create a large fishing area. The result was a huge swampland: water flooded the nearby fields and the landowners stormed out in protest. More recently, the Fucecchio Marshes was also witness of tragic events. In August 1944, one of the most ferocious massacre of Italy was perpetrated by the Nazi: during the slaughter of Fucecchio Marshes, 174 people were brutally killed.

There are also many representative historic and artistic exemplars which testify to a glorious past: the succession of different important dynasties, famous artists, the compromise between power and culture, wealth and creativity. Villa Medicea in Cerreto Guidi, which today houses the Historical Hunting and Territorial Museum, was built upon an existing castle of the counts Guidi, who gave the name to the area itself. The building, which has a double ramp in brick leading up to the entrance, is attributed to the Florentine architect Buontalenti and was built as a fortified hunting lodge for Cosimo I. The Tuscan Renaissance courts like those of the Medici used to “catch” the best talents of our country to commission them works of art which became well-known all over the world and attract many visitors in our territory. Also the most famous citizen of Vinci entered the service of patrons in different courts: Leonardo (from Vinci, indeed) is widely considered to be one of the greatest artists of all time, a polymath who could associate humanistic theories, painting and pragmatism. His worldwide famous paintings and his discoveries in engineering are considered a universal heritage: from Mona Lisa to The last Supper, from the Atlantic Codex to the leonardesque machines, from the invention of dams to hydrodynamics and military devices. Leonardo spent in Vinci his childhood, his character developed in the Tuscan environment which increased his curiosity.

Many protagonists are strongly linked to this territory, and their histories were related by one of the most critical writers of Italian journalism, Indro Montanelli. He was born in Fucecchio and personifies the dynamic and sometimes grouchy nature of local people, the passion for their work, their fight for what they believe in.

In such particular context, antoniolumi represents a hub of interpreting the Italian production and creativity, like a symbol of excellence of this territory.



### 3 - Yesterday Antonio Lupi, today antoniolupi

*“Courage and passion, vision and determination, tradition and innovation, victory and losses: a story about men prior to a project, a company made of people that convert dreams into products, a story that begins from a single man and becomes a brand, as always done by men...”*

A story of courage and passion, intuition and consistency, individuality and participation all wrapped into one word, vision. Vision never lacked from the history of the company that was born many years ago from Antonio Lupi's intuition, father of the 4 siblings that run the company today. As all success stories it wasn't easy, on the contrary, a tortuous road made up of important stages, partial fallouts, recoveries, consolidations and affirmations. A story based on ideas, the right ones, often successful and always creative.

Antonio Lupi, born in Vinci, the town of Leonardo, begins his business in 1950 in a small warehouse in the town of Fucecchio only a few kilometers away from the current location of Stabbia. At only 18 years of age he begins his production of glass for furnishing; a turning point for an agricultural family, a revolution in the area of the Val d'Arno where most companies were involved in different sectors.

Antonio begins introducing his product, from glass shelves to glass showcases, starting a small network and shortly afterwards introduces bathroom mirrors. We are now in the 60's, years of an economic boom that radically changes the country and transforms the bathroom into a private room in every home. Success is achieved immediately and the company grows from supplier to manufacturer of bathroom furnishings with the name "Crystal Lupi Luxor". The current warehouse starts to feel small and the company re-locates to Stabbia, where at that time there was nothing except the road, the ideal place for expansion. "Crystal Lupi Luxor" opens a new factory in 1969. The final transition from artisan to industrial, Lupi hires more than 300 people (almost all from Stabbia or neighboring towns) and the roots between the company and the town become even more intense, almost unbreakable. Success lasts for several years, production is extended rapidly including mirrors, lamps, small accessories and even bathrobes. We are at the beginning of the idea of a total look that will find fulfillment only in the 21st century, but already the impression was strong, the goal was clear and the future path drawn up. The company opens its first direct points of sales, even crossing the border and establishing a headquarters in Cannes to oversee the French market. The establishment in Stabbia grows and the company diversifies its production by including that of double pane glass for the construction industry and organizing a true glass business. Suddenly the market changes and the company fails to comply. The difficult period culminates with temporary receivership in 1981 (it will last until 1983) and during the most difficult time begins the comeback.

Antonio's son and daughter, Nello and Patrizia are already involved within the company respectively at the French headquarters and buying office/management provider. Andrea enters the company, the second born, and marks the real turning point. His schooling had been nothing short of tortuous (his accounting studies imposed by his father failed) and Antonio gives him a choice that will change the course of events...It was more like an ultimatum. It was September 1981 and when he calls him in his office Andrea remembers two empty chairs in front of his father's desk: *"he said, so you don't want to study anymore, here's a briefcase with samples, our agent of central Italy has just quit, travel around, get yourself known, present our products and try to sell them."* Travelling around Tuscany and Emilia Romagna is hard and not easy for Andrea to find himself in this situation but soon realizes that out on the field you really understand if the company is moving in the right direction. The company was not on the right path, things are changing fast in the country as in people's homes and so it was necessary to make a quantum leap. *"I realized that people no longer needed our products, everything was changing and we were standing still"*. With a lot of creativity and little investment (in addition to the pressure of a father who did not agree) he creates a small collection of bathroom furniture systems and presents them for the first time in Cersaie 1983. It's a big success, Andrea returns with a great number of orders (in that time you really sold a lot in trade shows!) and decided to work on it. *"It wasn't an opportunity but the only possibility to make a comeback, we didn't have much of a choice. We were forced to start a new adventure because we had to satisfy all the requests from the show and that meant manufacturing in a serious manner."* His brother and sister follow and they restart from Fucecchio with a new company named Gilly of Lupi Patrizia (the name of a historical coffee shop in Florence) a new adventure. Their father observes from far away and doesn't get involved, he sees they're growing and need to learn on their own. In fact, he's too proud of his

creation and unable to abandon his ship even when it has irretrievably gone adrift. He's stubborn, as everyone in the family, and it takes a while to convince him but his children make him feel important by getting him involved in the project. His name still carries weight within the industry and what he did for many people is not forgotten. He starts travelling to propose the articles of the new Antonio Lupi...It is now 1988 and since a couple of years the company had changed its name to Antonio Lupi Collezione Bagno. Antonio is the commercial director, Patrizia is firmly head of administration, Nello and Andrea do the rest, Sergio is still too young to participate.

Success comes fast and consistently and soon the new company with 30 employee's needs more space. Antonio Lupi returns to Stabbia in 1991 buying back part of the old establishment in the meantime gone to auction. The company starts back up from where it left off but with new ideas and new strategies. The company grows fast and starts introducing their own designs. They start from what they know best, glass tops with integrated sinks but are shortly able to introduce new designs in ceramic with geometrical shapes. Minimalism that reaches its peak in 2002 with the first collection in Corian® and with the development of a bathroom completely tailor made. With the introduction of new materials the company continues using those traditional such as stone, marble, and even alabaster from collections such as Materia and Talamo. From that point on it has been continued success of introducing innovative collections from Pantarei with a structure cut at 45° to the fireplaces to the first radiators, frescoes, showerheads and sinks integrated in the wall. Meanwhile in 2007 and one year since the loss of Antonio and wife Mara, the logo is revised. An important modification because the graphics of the old brand was referenced adding value to a brand that is synonym of quality, beauty and passion for the bathroom. Today Antonioluti offers what is necessary to give life to an elegant and refined total look just as Antonio had dreamed about. His children made the dream come true and the story can only but continue...

### 4 - 4 siblings and only 1 company

*"Our father loved his work and his company; he put all his energy, hopes and dreams into it. He always said it was necessary to work, make mistakes and learn from them. We are like him, different but the same, we are strong willed but comprehensive, we are realistic but dreamers, moreover we're first family and after entrepreneurs..."*

Four different personalities, four distant characters, four ways of interpreting life but all associated with the same enthusiasm, passion for beauty and conviction that if you want to achieve something you have to give it your all as well as the certainty of doing what we know best leaving the rest to others. Nello, Patrizia, Andrea and Sergio lead today an innovative company projected for the future. A unique capability of foreseeing trends and ways of living the bathroom. The Lupi siblings are aware that their success comes from the past, they know how to benefit from it and that what they lived will never be forgotten but will be a lesson in growing. They're the leaders of their company because they live it 100% together with their employees. They're always in the office or in the factory, responsible, each for their own duties and in reality have control of everything constantly confronting new ideas and willing to grow.

At times, decisions are important and concrete for the future of the company, in other instances a new project is under construction. Some designers that work with Antonioluti love how the company seriously plays and has fun at it. When the game is over creativity leaves space to concreteness, consistency and guarantee for the client.

The subdivision of duties within the company was very natural (Antonio was right) the internal balance is given by a mix of creativity, expertise and natural predisposition.

Andrea is the front man of the company, extroverted by nature but at the same time reflective, creative and competent of very technical details. Today he is responsible for planning, research and marketing. Accounting was only a small parenthesis of his life, sooner or later the creator had to come out and when encouraged gives life to greatness. Andrea, along with his siblings, relieved the company in time of difficulty overcoming opposition from a father not willing to accept change. The siblings decided to go ahead and that it was necessary to change to give a future to their family and company. An approach that comes from the passion of the constant research of an idea, to never stop, always look ahead and to always be ready. If Andrea feels tight it's because he's constantly

researching new ideas to never stop, intuition does the rest, if to follow or not a project and when is the right moment.

Patrizia, the only woman amongst the siblings, has always been in charge of administration. Her father noted her capabilities when she was only 17 after her internship in the shipping department and was soon assigned to the most important role, the buying office. *"I had a lot to learn and had to gain the trust of who wasn't pleased to take orders from the owners young daughter."* Since then she has always been in charge of "balancing the books" and in fine tuning her brothers uncontrollable enthusiasm and creativity. A complicated role between compromises, dreams and reality. Outnumbered, probably the reason for her assurance and strong character without forgetting her role as a mother, wife and woman in a man's world...

Nello is the oldest and indisputable king of production. He has complete knowledge of materials and how to work them traditionally or with innovative technology. More introverted than his brother and practical, speaks only a few words and more quiet than his brother Andrea, opening up when he speaks of how the company has reached a high level of quality. He becomes enthusiastic about the workmanship of his employees, he becomes happy when able to engineer a new project and to give shape to his brothers thoughts and those of the designers. Nello doesn't avoid problems he confronts them. He was the first to enter their father's company at only 14 years of age and to have lived the beginning, the difficulties and the comeback. Surely the sequence of events have fortified and made him grow. Expertise grows with time by working on the field amongst the various experiences and not always positive but everything helps in molding a man and his professionalism. He expresses himself with confidence, is in production to resolve problems, improves production and assists his employees in constant research of perfectionism. He has a frank relationship with his employees based on trust and little words. New technologies require awareness of every aspect of the production. Passion is noted in the details of how he keeps under control details and complicated procedures and the overall organization of production scheduling.

Sergio is the youngest, born in 1977 he inevitably was the last to take part in the company. *"I was very good in school, at only 13 Andrea and Nello taught me what I would do when I grew up. For a long time they controlled my every move, now I'm free to make my own decisions even if confronting them is constant growth and improvement for everyone. Only through sharing and brainstorming can we obtain better results."*

Today Sergio is in charge of custom made items and client relations, practically everything because all products are special for Antoniolupi. Thanks to his tailoring approach do the different projects take shape. Each one has found their calling. Through hard work and mistakes the four siblings are serious and competent professionals. The credit goes without a doubt to their father and to his capability of giving his all in something he believed in.

The biggest lesson of Antonio and his wife Mara, married in 1957 and passed away both in 2006 was better quoted by Patrizia *"Before being partners remember you are family, he loved to repeat. Our father taught us to stick together, he always said that union makes strength and that only if we stick together will we go far. We haven't let him down, I think he'd be proud of what we've achieved today."*

Now are the nieces and nephews...the third generation. They're still young to be put to the test but Andrea, Patrizia, Nello and Sergio are already at work for their most important and hardest project:

Pass on the passion, the desire to create and the love for the company, make them really understand what it means to be part of Antoniolupi...

## 5 - In the courtyard of ideas

*"We have reconstructed piece by piece our father's factory but we were not satisfied with this so we went further. We wanted to create a place where it was possible to live an unforgettable experience trying to make every client, partner or designer feel at home, because this is the only way to give life to great ideas."*

People do not pay visit to antoniolupi just to design new projects or see products; they go to Stabbia to live an experience, to immerse themselves in an inventive and inspiring atmosphere, to know, understand and grow from.

Surrounded by a unique scenario of Tuscan hills the company's headquarters extend to 16.300 square meters on the same land that housed Cristal Lupi Luxor owned by Antonio Lupi. The old factory,

auctioned off after experiencing difficulties during the early eighties, was bought back with large efforts from the new antoniolupi in 1991, when Andrea, Nello and Patrizia decided to bring back their production in the same place where their father started his activity. It wasn't easy to buy back and fix the old place. *"We had to do everything on our own – Andrea says – many people turned their backs on us but we really wanted to come back to Stabbia because it was the right place to start from. With determination and hard work we did it"*.

First the production plants and offices, then the new glass factory. The home of antoniolupi takes shape hand in hand with the success of the company. The buildings are recuperated and adjusted to the current needs, production plants are renovated either in design or technology, offices take their shape to support the new brand philosophy and image of the company. This is the beginning of constant development intended to satisfy mainly production requirements, for space is never enough, because the idea is to give life to a large open space surrounded by buildings, each with its own specific function. As often occurred during Tuscan Renaissance, the company becomes the hub for anyone who wishes to contribute creatively and with expertise. The scheme of the plant is clear from the beginning: offices occupy the front, while the side wings house the factory showroom and the production. The front office building where the reception, administrative offices and meeting rooms are has become the link between the past and the present due to a new area dedicated to the gallery of images that tells the history of the company. A photographic journey that marks the most important stages of a great story but also a way to welcome and involve visitors and clients illustrating to them the origins of the company, which paths have been taken and which strategic decisions have been made and the results achieved.

On the right side of the courtyard is the factory showroom. A unique place rich in atmosphere and details, a silent place (notwithstanding the near production plant) where people can free their mind and appreciate the collections. The soft lights, the music in the background, the flames of the fireplaces and the sound of water are all elements that allow visitors to live an experience of total relaxation and at the same time touch with their hands sinks, bathtubs, sanitary-ware and all other products gathered by the same elegant and refined style. An inspiring setting where it is easy to give life to imagination and perceive the importance of colours, textures, and surfaces in relation to the surrounding space. From the elegance of glass to solid aspects of materials, from the ephemeral presence of fire to metallic reflections: the showroom setting is constantly renovated to welcome brand new collections integrating them with existing ones.

On the opposite side of the courtyard the production plant occupies several buildings. From the paint department to the assembly line, from the packing department to the stock of raw materials, and stock of accessories ending with an area dedicated to shipping.

A simple layout for processing orders and pass rapidly to a finished product. The glass factory is the only exception because in a more hidden area to guarantee easy movement and safety when working with large sheets of glass from which sinks, consoles, mirrors and mirrored cabinets are produced from.

Three buildings rise up in the place originally occupied by the Cristal Lupi Luxor factory to complete the courtyard on the back side. These parallel spaces, characterized by barrel vaults, represent a free industrial area without internal divisions.

In June 2010 one of the buildings, originally dedicated to the packaging of mirrors, was renovated for two new protagonists of the antoniolupi collections: the stone sinks and monolithic tubs as well as the fireplaces. The 1100 square meters were completely emptied to make the architectural elements visible through a refined renovation. This is an ideal space to accommodate the sculptural and sometimes imposing products, to appreciate the sensuality of materials, to test the fireplaces and contemplate the flame. In this "industrial living space", a sort of hangar or large loft, people find a unique atmosphere: the heat of the fire and the smooth stone surfaces contrast with the hardness of the unfinished walls awakening all senses. The name of the new showroom is, *La Pietra e il Fuoco*, contrasts externally with the rest of the space. A matt lacquered black façade draws immediately the attention of visitors, less attracted by the grey walls of the other buildings.

Centrally located since 2012 is a "magic lantern" representing the cornerstone of the entire plant. *Il Giardino delle Idee*, a space dedicated to projects, research, development and where creativity finds its place. This three story building with its glass front looks upon the green area of the courtyard bounded by cypresses and osmanthus bushes. The entrance of this building is characterized by the presence of nature: a large greenhouse with a tropical garden where different plants create an organized jungle as well as a green filter hiding the offices on the other



side that are offered a relaxing view. Lush greenery that highlights the formal simplicity of the external walls, made of innovative soundproofed glass. On the ground floor there are two conference rooms and one archive/library; on the first floor an open space with a meeting room, a brainstorming room and an operative area with 18 desks. On the second floor a kitchen/relax area that leads to a large balcony with a beautiful view of the factory and the surrounding hills. A place to rest, converse or be alone but also a great place to organize events. With Patrizia Lupi's beloved collection of roses, *the Garden of Ideas* matches perfectly the essence of antoniolupi. A company where people can creatively work in a team, live in contact with nature, share opinions with others to offer products and ideas, always a step forward in the future.

## 6 - A story that starts from a vision

*"An idea and its sign underlie everything. I have never done market research, I don't need to do much to know if a project is the right one, I have only developed those projects that I liked and that moved me. Often the product is looking right at you, you just have to be able to see it!"*

Courage and perseverance to face a tortuous path, flexibility and coherence to find new ideas maintaining the same style, ability to imagine possible future developments of a project: these are essential skills for a businessman and his collaborators, and antoniolupi has them. Andrea is catalyst of new ideas, contaminations and suggestions which are translated into products with a strong identity, able to match perfectly the tailor-made bathroom concept of the company. A "tailored dress" designed according to the request of the client, with products combined with architectural elements, light, surfaces and all other components of space.

Antoniolupi creates charming and elegant ambiances which arouse feelings, generate unique experiences and tell stories...*"I like talking about projects and not about product and to do so I love involving diverse professionals such as architects, designers, technicians, graphic designers, anyone who can contribute to improve a project. We don't want to replace them, but cooperate together to create something magic"* says Andrea. Every project, developed through a traditional research method or through Andrea's ability of reinterpreting the sketches proposed by designer or architects, is then converted into a collection or a range of products. Sometimes projects are commissioned to reliable designers, sometimes they come directly from personal initiative of architects. *"Some designers are more formal, other more technical. The company has to be aware of what can be produced because it's useless to chase unconceivable dreams or confront projects that are not in our range. Every designer has his own style, some have a soft and baroque touch, others a minimal and refined taste similar to antoniolupi's. In both cases our job consists in improving the original idea through a straightforward approach even with designers that appear different from us"*.

Many collections come from similar collaborations, e.g. for the Talamo series, designed by Domenico De Palo, originally proposed as outdoor seating and later transformed into bathtub and sink in apricena stone. *"I was looking for someone who could extract the best features from local stone, I knew that antoniolupi could do it. I was thinking of an outdoor collection, but I was in the house of baths yet the destiny of my project was clear..."* says Andrea *"I still remember that day of 2008, when Domenico visited me with a series of stone scale models for an outdoor collection and I immediately told him that he was in the wrong place. However, I appreciated those models, they had a beautiful shape and were well made...behold an idea. I told Domenico that the new collection was in front of us, we just had to dig further to pull out bathtub and sink. Talamo was born and later proposed also in Cristalplant"*.

A partnership that with De Palo has led to the creation of some of the most important products in antoniolupi's collections.

*"When he proposed to me to investigate the subject of fire, and in particular to develop a collection of bioethanol fireplaces I immediately wondered: what does a bathroom producer have to do with fire? We didn't have a clue, we didn't know where to begin, I didn't have any idea how we would communicate and distribute this kind of product. However, Domenico's design convinced me once again, that cut in the surface he designed was so elegant and essential that it was worth the try. No one had ever included a fireplace in their bathroom and so I accepted the challenge"*. The involvement of the master of fireplaces, Massimo Pistolesi, was crucial to fill the gap of expertise in the subject. Together with the company he finalized all technical aspects for the new collection of bioethanol fireplaces Il Canto del Fuoco and his contribution

was decisive even afterwards in the later collection of wood fireplaces, Skema, designed by Mario Ferrarini. As often happens at antoniolupi, a project never ends in itself as it does not conclude with its realization but instead it continues to influence the following collections. The theme of " wall encasing products " has obliged the company to a long study over integration between space and its composing elements. A different way of reading projects, a different method of intervention that sees the company side by side with interior design in early stages of the project so that these products can express their best.

On the other side of the design of Il Canto del Fuoco and replacing fire with water we created a new collection of sinks Strappo (in 2012), elegant objects that come out of the wall surface without any visible interruption. They are entirely made of Corian®, they are plastered and finished to finally merge with the surface of the wall. A different design but same concept of " encasing " for SESAMO designed by Studio Arkimera. A collection of bathroom accessories created with the young studio and presented to Andrea during Salone 2012. From an idea to a collection of revolutionary concealed accessories that become visible only when you need them. In the same year the complete collection was displayed at the Cersaie fair, this happened after only 5 months of development. The collection allows a perfect integration of the elements that are disappearing in the wall and are only recognizable by the thin perimeter lines of niches.

Ceiling encased shower heads are still part of theme, they were created in 2011 and designed by Nevio Tellatin. A very complex project from a technical point of view. The rainfall effect created by water turns a minimalistic design into an emotional experience, in perfect Lupi style.

Exelen collection, designed by Oscar and Gabriele Buratti, opens up to concepts of " tailor-made " and mix of different elements, materials and functions reaching their best expression in bathrooms. *"I chose the Buratti studio for their ability to work with the many stages of a project. For this collection I was in need of somebody who was able to read space in its complexity and completeness, someone able to perceive the value of proportions, necessary spaces as well as the balance between positive and negative spaces. Actually, our relationship was born for a different project. With Abol I had tested them for reinterpreting a ceramics wc from a resin seat"*. Exelen is an integrated collection where all its components are designed to match with each other.

They are formally coherent and coordinated, their features are rigorous and determined but also soft and embracing to allow the possibility of forming unusual and customized combinations. And we reach year 2014, with the latest project presented by the company *"We were looking for a project that could embrace a different style far from our own and from excessive pure and essential style. 90% of the world's bathrooms are furnished with classical style furniture, we had to propose something"*. It was a difficult challenge because it was different, a reinterpretation, this time very formal, of the most classical/baroque style in a contemporary style. Andrea sees in Roberto Lazzeroni the ideal designer for this collection and leaves him full freedom imposing only one condition. *" For a long time I had thought of re-editing my father's mirrors, and thus I told Roberto to begin from the mirrors, that had to be the starting point of the collection around which we could design a complete proposal with a new language"*. ILBagno is a bourgeois and romantic collection as Andrea loves to define it. It is a less rigorous and minimalistic collection and recalls memories and suggestions of past styles. A revision of past contents obtained through antoniolupi in a typical clean and pure style and through extreme attention to details and excellent work and materials employed.

The latest collection re-starts from the beginning, from the first steps of Antonio's company: ILBagno brings continuity into innovation, coherency of vision and love for beauty and well made things.

## 7 - Man is the centre of all things

*"We are proud of being a 100% Made in Italy company that exports to many countries. We would like to consolidate and improve this position and look at the future with the awareness that Stabbia and Tuscany are our home, because we were born and raised here".*

*"Nowadays export represents the only chance to survive for companies like ours. But we do not want to leave Italy, because only if we work here we can maintain a top level of quality which is required for exporting worldwide".* This is the strategy of a company that is looking ahead trying to always face new challenges and explore new markets without forgetting from where it started and without neglecting its territory, its origins and its culture. From Italy, antoniolupi, is a world leading company in "tailor-made" bathrooms. Being a 100% made in Italy company, today, is a warranty of creativity, innovation and style. With a turnover of Euro 26.000.000 in 2013 +7% improvement (30% Italy and 70% export), antoniolupi has 80 employees and works in 52 countries through flagship stores or authorized dealers. An international operation, coming from the will of Andrea and before an idea of Antonio, to explore new and distant markets. *"we have always looked at export market with interest and since 2006 we have started to attend international fairs with excellent results. We brought our style to Europe and America now we would like to start with Asia".*

North of Europe, Belgium, Germany, Holland, Switzerland, France and Russia are currently the best markets, together with the growing success of United States market with Chicago and Miami flagship stores. Contract projects are also an interesting opportunity for the company because of the wide collection that antoniolupi is able to offer and also for its ability to collaborate with interior designers from the early stages of the project. All antoniolupi collections perfectly match with contemporary style interiors. In many cases it is very important to think about the interior design starting from site project phase so as to obtain the best final results. In big contract projects antoniolupi can provide a top quality product and also customization of it as well as professional service and best production lead-times. With time, the number of collections available has increased with the aim of having a total concept for the bathroom but also products that can be easily adapted in all home interiors. Antonioplupi has not restricted itself only to the bathroom area but after having studied other themes and opened up to a new brand extension, presented at the last edition of Salone del Mobile in Milan a new project for the kitchen area. Antonioplupi did it in its own way, with its style "without a second thought" but with awareness and coherence related to its history and name. The company presented a new kitchen project starting from ideas, design and vision. The project LACUCINA will be the one in which the company is willing to concentrate in the near future because the bathroom remains the core production but its borders of course will be broadened and augmented by other home interiors elements. *"In fashion industry it's very common that a successful brand proposes clothes but also bags, glasses, shoes all with the same coherent style and identity. We would like to give our clients the possibility of having in their homes antonioplupi bathrooms but also antonioplupi fireplaces or kitchens".* Thus, antonioplupi has clear ideas, ambitious projects, and integrated home furnishing proposals all suitable for contract projects but also: *"When you are presenting a bathroom with a strong character, a refined style and a high level of customization, architects are asking for a coherent design of the same brand also for kitchen, living room or bedrooms. The More is complete the offer the greater the interest of architects to promote such a brand".* Andrea Lupi and his brothers know that the success of a brand is achieved through important decisions, commercial and distribution strategies, marketing and communication, promotion and diffusion of products, but they are conscious of the fact that the project is crucial, that "the holy fire" of creativity should never stop and that the main characters of success, like in real life, are man and his territory. A territory that needs to be loved and respected through a true and real sustainable approach that starts from the use of recyclable certified materials, the use of water based lacquers, or the rigorous division of production waste. A love towards the territory and in general for the environment that is housing us, which is not an imposition to be subjected to, but a natural attitude for those who have always lived intensely in privileged contact with the territory and wish to preserve it for future generations. Because as Andrea says, man is always the centre of all things: *"Every day we work with passion, with the aim that bathrooms and future homes can become a space of experience. A tailor-made space, customized for body and soul, because man is the centre of everything we design".*

## 8 - Listening, analyzing, acting: "being" the future

*"We live of innovation. We can't stop because it would be a great mistake for the company. We are continuously in search of new ideas, sparks and blends. We can't follow the evolution of design trends, we have to anticipate them. I would love to be chased".*

Innovation is part of antonioplupi's DNA. It's the distinctive feature of this company from the very beginning, when Antonio Lupi created his glass factory, and even more today with his children leading the company. A 360° innovation: from product development to the workmanship of materials, from the way in which collections are exposed to the high identity of the factory's organization. In this manner, everyone involved is a part of the development and is given the possibility to improve. Throughout the years several unique collections have been introduced and projects which show the great purposeful perspective of the company have been accomplished. In every project antonioplupi takes steps forward while gaining experiences that bring to technical and production improvements.

2002 represents a crucial year, because it saw the beginning of Collection 2002, the first bathroom collection entirely made of Corian. This project shows Andrea's approach to research, functional, and able to convert ideas in true feasible projects. *"We were the first company to propose a collection completely in Corian. Although I love ceramic, a material of the soil, I was aware of its limits. There were other materials that allow new manufacturing methods, while ceramic cannot be molded in every shape. Because of our tailor made approach, we needed a new malleable material. Nevio Tellatin and I worked hard on Corian slabs to create Collection 2002, a project complete with sinks, shower trays and bathtubs. These products marked a turning point in bathroom furnishing".* It wasn't easy, but Andrea believed in this new project and antonioplupi decided to start working Corian. *"We had many doubts about costs and feasibility, we wanted to start working on custom-made products, so we had to change radically our production methods. Corian is a very expensive material, difficult to work and mold...for us it was a "first time". The risk was to offer products that were too expensive and not functional. Fortunately my worries were unfounded. The Slot sink represents a symbol of antonioplupi, because it has no visible functions but it works perfectly!"*

This project proves that research is required for every plan, even if it seems to be easy or insignificant. *"For me this is a true innovation, that is, having an idea which is converted in a project and then in a concrete product thanks to research in materials. Without that specific material, that project wouldn't have been possible".* Without Corian and its feature of being molded in different shapes, it wouldn't be possible to create custom-made shower trays and perfectly smooth surfaces. *It wouldn't be possible to solve problems related to walls being out-of-line as well. Not necessarily does innovation mean new materials. When in 2003 we started the project, Materia by Carlo Colombo, Andrea and the whole factory had no problems to turn back to its origins and work stone. "Marble and stone were the perfect material to represent the smooth design of the collection presented by Colombo. We had no doubt in choosing these materials".* Besides stone, other various handcrafted objects in local blown glass were presented as well as an innovative tap collection with a rectangular shape for sinks and bathtubs.

2006 is also a decisive year for antonioplupi, above all for bathroom furnishing. Considered until today one of the company's main sector, the furniture are the unconditioned protagonists of Panta Rei collection, designed by Carlo Colombo. *"It was the beginning of all innovations in the furnishing sector. The high quality level of Panta Rei represented a standard for all our collections".* For the first time, antonioplupi presented cabinets, sink units, furniture and open shelves with a 45° bevelled edge. The accurate lacquering of Panta Rei and its perfect veneers completed the precious style of this collection.

A true revolution for bathroom furnishing was introduced in 2008, when fire appeared in the bathroom for the first time. After presenting Il Canto del Fuoco, several companies started proposing bioethanol fireplaces to heat the atmosphere and to diffuse comfort and wellness in the room. *"Fire is like a silent friend that helps us to relax with its delicate presence".* Immediately after presenting this new product, Andrea went further: he wanted to propose a "true" wood burning fireplace with an essential and clean design, in which fire was the real protagonist. In 2010 appeared Skema, designed by Mario Ferrarini, a modular wood burning fireplace that beginning from the mouth can be further developed with different elements (burner, open shelves, drawer for wood...). The collaboration with a fireplace-expert, Massimo Pistolesi, was very important to develop



and refine this formal and technical project. As Pistolesi says mentioning Heraclitus: *"Fire is ever-living and moves continuously; every moment is different from the previous, but remains always the same"*. This metaphor about life changing continuously can be applied also to antoniolupi, because the company wants to be able to change and improve, without forgetting its own identity.

With such a peculiar product like fireplaces, antoniolupi's line embraced a wide variety of products, including sanitary wares, bathtubs, sinks and also leather mats characterized by a simple and essential style designed by Riccardo Fattori.

The outdoor sector plays also a central role for the factory: in 2012 was presented Oio, a glamorous freestanding sink designed by Michel Boucquillon. A new, economic, easy and light sink that you can take easily move in a new material: polyethylene, eco-friendly and available in different internal led colours.

Since the variety of bathroom products is considered complete with several tailor-made collections, in 2013 the company works on surfaces to offer the possibility to personalize their space not only with "objects", but through the architectural components that define them. Thanks to the collaboration with Pietro Gaeta on decorative techniques, antoniolupi presents Affreschi, a sort of wall covering that creates a perfect background to sanitary wares and encased sinks. A modern project originated from the ancient frescoes technique and interpreted in a new contemporary perspective. Thanks to a special paper that allows to transfer every image directly on the wall, the fresco has a high degree of customization. A new successful challenge for antoniolupi: *"In only six months we managed to present an unusual project, which is quite distant from our style"*.

Now we really have everything, or maybe not. One technical element transformed today in decorative object is missing: the radiator, a product with a strong personality that can change the atmosphere of the room. BIT, designed by Brian Sironi, is the first designer radiator presented by antoniolupi. Its linear shape and rhythmic protrusions transforms it in a sort of contemporary low relief. BIT, in its water, electric or combined water-electric version, is entirely made of recycled aluminum and is available in different colours and dimensions.

Even if the range of bathroom products seems to be completed, Andrea is aware that the company can't stop and has to go forward. He explores, thinks, dreams...and decides to face another big challenge: the kitchen, LACUCINA. *"I met Marco Casamonti at our stand during the fair Cersaie in 2012. He asked me if I was interested in producing something different from bathroom furnishing. Honestly, the kitchen has been in my mind for a long time so I said that if the project was convincing, I would have tried to develop it. On his iPad he showed me a rendering of a C-shape shelf that struck me immediately. I understood that it would take a lot of time to develop the project, but that particular detail convinced me. I accepted the challenge. I know we can make it, I answered, and after two years here we are with LACUCINA"*.

This new project has a strong formal impact, which foregrounds food and the preparation of dishes thanks to a continuous Corian surface, available also in customized sizes, where food, accessories and kitchen utensils can be housed. The large C-shape shelf represents the main element of the kitchen giving it a strong identity.

Although this new project is a difficult and complex challenge and unlike how the company currently works, antoniolupi is embracing it with courage and expertise, analyzing all its different aspects. Andrea has attempted to discover its secrets making them his own digesting them and reworking them to present a complete and feasible project, once again...this is called innovation!

## 9 - Ethics and aesthetic of know-how

*"We work with people that do wonderful things, artisans who can transform materials and take care of them as if they were artists from the Renaissance. We just need to help them to keep loving what they are doing"*.

An extensive network of more than 200 artisans who work different materials with expertise and workmanship, a cradle of histories and creativity that can face any challenging project to meet the expectations of customers and the requests of the company. Since the territory plays an important role for antoniolupi, in his projects, Andrea involves local craftsmen to create products full of expression and culture. *"We have to protect this unique heritage of knowledge...even if our collections have a minimalistic and contemporary style, we have to preserve also its*

*artisan nature. Antonioplupi is constantly committed to show its industrial production ability offering at the same time the possibility of customization which is typical of craftsmanship"*.

The goal is to reinterpret and rediscover tradition and history to convey a knowledge in materials and manual skills that we have put aside too many times because were in search of ephemeral values or technology at all costs. *"Often local craftsmanship is more important than the project itself. We believe that only through this we can express our calling for "tailor-made" collections and highest quality standards"*.

The English philosopher John Locke (1632-1704), said that *"No man's knowledge here can go beyond his experience"*. This means that we have to learn from our history, respect the environment and reinterpret the past to get new ideas for the future.

Unique materials like stone, alabaster, marble coming from Carrara are selected directly by Andrea and then crafted to get rid of the surplus and find the true identity of materials. Only working like sculptors we can create exclusive collections, with smooth surfaces and sinuous shapes. Products like Materia or Talamo (even if the stones employed come from different places) lend to the bathroom a particular relevance, they are a piece of history and plunge ourselves in a millenary heritage. Such important materials require specific skills and craftsmanship that cannot be reproduced in industrial scale to achieve highest quality standards.

The liaison between antoniolupi and the territory is even stronger when talking about glass. This is the very first material employed by the company: the famous glassmakers in Montelupo used to produce bottles for Chianti Classico wine and Antonio Lupi's wife, Mara, and her family wrapped them with straw. Later, sinks in blown glass produced by the best craftsmen of the area were presented in antoniolupi collections. Every material typical of this territory has a special connection with antoniolupi, like majolica, mats and leather objects coming from the local leather factories. Also wood manufacturing plays again a very important role thanks to the new romantic collection ILBAGNO.

The development of the company is related also to the constant collaboration with unknown artists who transform their ideas into works of art. Experts and reliable partners who cooperate with the company to improve and grow together, because as Patrizia says, *"the success of antoniolupi is not only due to the success of the brothers, but also to all people who have contributed to make antoniolupi a leading company"*.

## 10 - Details which make the difference

*"We have worked with many different materials, traditional, innovative, each with its own features. Only glass is eternal, resistant, un-scratchable. My father started from that, and even if today glass has been put aside in modern design, we will never forget our most transparent and pure soul"*. Nello Lupi

*"God is in the details"* said Ludwig Mies Van Der Rohe, one of the pioneering masters of the Modern Movement. For antoniolupi details play a central role because they guarantee high quality representing at the same time a production hub. If we analyze details can we notice the differences between great and small companies, between innovative products and meaningless collections, between projects that mark a trend and others that follow.

antoniolupi pays great attention to details in their production cycle from raw materials to finished products, the production process consists of mechanical or manual manufacturing, which require both technological and human skills. The permanent features of antoniolupi products are perfect final results with the highest quality standard. We produce by order only and don't have stock. Every element destined to a particular project has been planned and produced to meet the requirements of that specific client, who has at his disposal many different materials, colours and finishings in order to develop his unique bathroom concept.

Large attention is paid also to antoniolupi's suppliers, mainly Italian but above all from Tuscany. All doors and furniture structures are in birch plywood fitted with different accessories; glass is bought in large sheets, while marble and stone come from the nearby Carrara quarries and Corian has been employed by antoniolupi for a long time. Bathroom furniture represents a considerable part of antoniolupi production and a large part of the plant is dedicated to preparing the structure, cutting wood

for cabinet doors and drawers, lacquering and assembling the various pieces. Every operation is completed according to the clients request: wall cabinets and sink units, columns and drawers in every colour and finish have to coexist with different elements like sinks, bathtubs and sanitary ware in a synergic aesthetic union. The 45° bevelled edge of some collections allows to create refined drawers perfectly assembled in the furniture, which are then fitted with various accessories as hinges and runners.

Nowadays by demand, 80% of produced furniture are in lacquered finish. Wooden panels are cut, shaped for siphon and drilled according to the drawing before being lacquered. The painting process is regarded a success in the antoniolupi production method, since every piece is manually coated with eco-friendly toxic free water lacquers. Lacquering is carried out by specialists and consists of two layers of internal polyester and two layers of external polyester. Once the piece is dry, two layers of matt or glossy finish are added. All lacquers are prepared in the factory according to the sample or to the clients' request. Today antoniolupi offers a range of 55 colours in matt or glossy finish; every day 10/15 different lacquers are normally employed by the antoniolupi paint department. After being lacquered, the cabinets surfaces are dried 12 hours long in a drying room at the right temperature and humidity level. Later, the pieces are sanded down to remove any defect or excess paint. If required, they can also be polished to obtain a mirror effect. Also the plywood cabinets are carefully veneered in order to highlight the natural design and the precious texture of the wood. The horizontal wood grains cause a higher degree of difficulty in manufacturing the panels, but guarantee a unique result, since the whole structure of the cabinet seems to be covered by a continuous "skin" characterized by irregular grains.

Another top sector of the antoniolupi production is the glass factory, which represents a beloved place and a symbol of the company, where everything started from many years ago. In contemporary design, glass doesn't normally play a leading role, perhaps because of its features which make it difficult to manufacture and to interpret. antoniolupi does not agree with this. *"We have always worked with glass and will continue to do so, respecting all the characteristics of this material"*, says Andrea. Also in the latest collections, precious glass furnishings are combined with sinks and sanitary ware in a light and elegant style.

People perceive the importance of glass crossing the threshold of the glass factory. Glass is handled and manufactured with extreme care, in order to protect its pureness and its fine surfaces. From integrated tops to mirrors, from sinks to high cabinets – each product a result from a glass sheet provided by Italian and European suppliers. The sheets have different dimensions and thicknesses depending on the products they are destined for: they are thinner for mirrors and thicker for tops and sinks. To produce a polished edge mirror, the sheet is cut according to the requested dimensions, the steel frame is assembled and, upon request, also electric elements for lighting can be mounted on the structure.

To produce glass tops with integrated sinks, the process requires more attention and expertise. Thanks to high temperature of specific furnaces with a shaped mold, glass becomes malleable and the central part of the top can be melted into a sink. During this complex operation, temperature must be constantly monitored in order to avoid any possible tension and the consequent breakage of the material.

All pieces produced from the various departments are then carefully packed according to transport characteristics and the client's requests to avoid any possible damage. Each pallet corresponds to a specific order and is shipped once it is completed in all parts.

Corian, Ceramilux, Cristalplant, marble, stone, glass and wood a wide range of natural and artificial materials, textures, surfaces and colours which can be combined in an extremely high quantity of possible configurations. Everything highlighted thanks to the ability of antoniolupi's workmanship.

## Not to be taken for granted....

*"Some peculiarities of our production are taken for granted because we have always worked this way. Some people have suggested that we should emphasize such characteristics in order to let people be aware of our distinctive traits, our attention to products, and specific details of our work. We have always thought that a top quality product has to be made this way and every time we discover how to improve our production, we immediately adopt all measures to do it, because this is our philosophy. We know neither a different way to work nor we are easily satisfied with the achieved results.*

*What is not visible is more important to us than what is visible to all."*

## 11 - We are the others

*"Without our associates we would have never gotten so far, without everyone's sacrifice and hard work we would have never achieved these results, without the craftsmanship, the creative ideas and the management we would have never made it. This is about teamwork and we like for everyone to feel like protagonists."*

A company can reach high goals only if everyone works together; a project can grow and consolidate only if all its components plays a part of the success achieved (and not achieved). A successful family run business as antoniolupi works well when there is togetherness between upper management and associates, a healthy and constructive relationship that contributes to the good of the company and from this brings personal satisfaction.

antoniolupi's story is about sharing, blunt and honest relationships that have evolved and consolidated over time and about mutual trust and growth for everyone. The Lupi family, that has always run the company, has always been involved in all the major events of the company. An extended family, because in addition to the children of Antonio were other family members that took part in the adventure as told by Andrea *"My uncle Piero that already worked with my father in Crystal Lupi Luxor, followed us from the very beginning when we founded Gilly by Lupi Patrizia. It was a decisive engagement for us because his vast experience as production manager allowed us to set up a company according to rules of order, quality and clarity in relationships with suppliers that are still the essential conditions of our business."*

A man with great experience, Piero Giuntoli was enthusiastic from the very beginning, supporting completely the new project of Andrea, Nello and Patrizia. With the same enthusiasm he transferred his knowledge to the new Antonioplupi and still today contributes to the success of the company with his experience and strong will.

A similar story is that of Enzo, Patrizia 's husband, who was also involved from the beginning of the company Gilly in Fucecchio. When Andrea and Nello completely devoted themselves to all operational activities related to the production of the first collections it became necessary to introduce a representative in the Tuscan region and so the choice lied with the brother in law. From there a long partnership that continues to this day with new skills and professionalism built over time. *"Enzo was the first to introduce to the market our new collection of bathroom furniture. He started as I did, from Tuscany to today after almost 30 years is our Sales Director, a crucial and delicate role in the corporation that we decided to appoint to a member of the family. We needed someone who knew our story, who was involved 100% in the project, who shared our ideas and goals and we could trust blindly."*

Today Enzo Giachi works closely with the agents in all of Italy and works together with clients to satisfy their needs through the quality and tailored approach of antoniolupi.

In addition to these figures, which are part of the family, there are a series of silent collaborators, irreplaceable workers, men and women who give life to a brand established worldwide. Each stage of the process deserves attention, every aspect followed with professionalism and competence. Precisely for this has Andrea structured a team of employees who take care of the creative side from projects to graphics, showrooms to exhibitions, product development and special projects.

*"Everyone is important because in harmony with the company. I should name them all but I'd like to take as an example Riccardo Fattori who has been working with me for over 10 years in proposing a corporate image of the company and contributing his creativity by working on mass communication, product and graphics. His work is important in making visible the values, the style, the story, maybe better said as the poetry of Antonioplupi."*

And what does Riccardo think? *"To work with Andrea is very stimulating, we both have difficult personalities but I believe that in these years we've accomplished great harmony and a common purpose. Andrea is always on the go, always searching for something new, something beautiful, it's easy to become passionate about a project that is constantly changing for someone like me that can't stand routine. I must also say that my work is simplified because I have a team of fantastic colleagues that allow me to be "the poet" and give me all the time I need. For this I can only thank Andrea and his siblings for having considered my contribution important for their company and for having trusted me in all these years."*



**IMPORTANTE** [\\_www.antoniolupi.it](http://www.antoniolupi.it)

Per essere costantemente informati su novità e prodotti in modo dettagliato, vi invitiamo a navigare nel nostro sito sempre aggiornato. Nell'area download potrete scaricare tutto il materiale tecnico ed informativo che vi necessita.



Scarica l'APP per entrare nel  
mondo antoniolupi  
Download the APP to discover  
the world of antoniolupi

## LE COLLEZIONI

antoniolupi è un mondo completo intorno alla sala da bagno, un mondo che anzi, partendo da questo ambiente, si estende in tutta la casa. Troverete le collezioni nei cataloghi a loro dedicati.

ILBAGNO PANTA REI PLANETA PIANA TEMPRA LUNARIA EXELEN CAMINI





# THE COLLECTIONS

antoniolupi is a complete world around the bathroom that starting from this environment extends to the rest of the home. You can find the collections in their specific catalogues.

ILBAGNO PANTA REI PLANETA PIANA TEMPRA LUNARIA EXELEN FIREPLACES

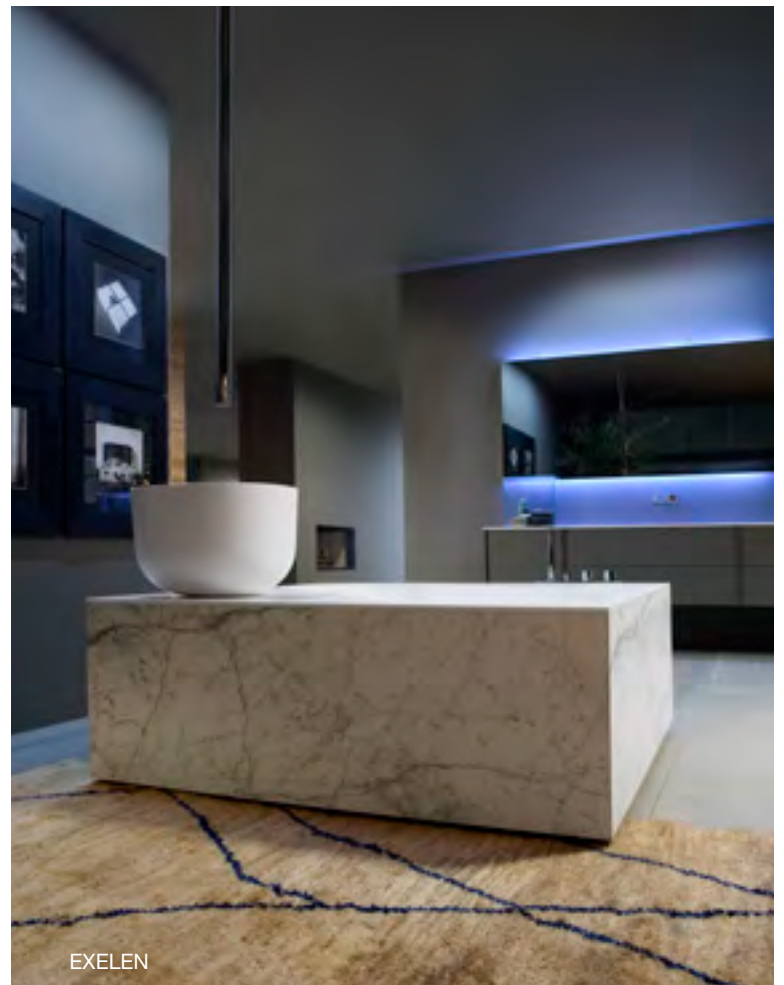

## BIT

BIT è un monolite realizzato al 100% in alluminio riciclato. Un termoarredo facilmente inseribile in qualunque ambiente, personalizzabile con la stessa verniciatura della parete o in contrasto di colore. Le lievi sporgenze in sequenza ritmica, determinano un leggero gioco di ombre che lo rendono scultoreo, un bassorilievo contemporaneo, una citazione delle superfici monocromatiche in rilievo delle avanguardie minimaliste della seconda metà del '900.

*BIT is monolithic made of 100% recycled aluminium. It is a versatile designer radiator that can be adapted to any space. The product can be personalized through painting it in the same colour of the wall or creating a contrast with a different colour. The light protrusions in rhythmic sequence create a game of shadows giving certain sculptural features as if it were a contemporary low-relief, a quotation of the monochromatic surfaces typical of the Avant-gardes in the second half of the 1900s.*





**TERMOARREDI / *DESIGNER RADIATORS***

termoarredi  
*designer radiators*

**BIT** design Brian Sironi

BIT viene fornito con fondo verniciabile in modo da poter essere personalizzato con la tinta desiderata, dello stesso colore della parete o in contrasto e poi se si vuole riverniciato, riverniciato, riverniciato...

*BIT is supplied with a paintable surface so that it can be customized with desired colour, painted in the same colour of the wall or in a different colour to create a contrast...and later it can be painted again and again and again...*







temoaredi  
designer radiators



**AMBIENTE**

**ENVIRONMENT**

BIT è realizzato in alluminio 100% riciclato, con un risparmio del 95% rispetto alla produzione di alluminio primario ricavato in natura dalla bauxite.

*BIT is entirely made of recycled aluminium with a saving of 95% compared to the standard production made with primary aluminium naturally extracted from bauxite.*

**AL > 95% AL**

L'alluminio pesa circa un terzo dell'acciaio (2,7 vs. 7,9 kg/dm<sup>3</sup>). L'alluminio è riciclabile all'infinito mantenendo inalterate le proprie caratteristiche.

*The weight of aluminium is one third if compared with steel (2,7 vs.7,9 Kg/dm<sup>3</sup>). Aluminium can be recycled perpetually maintaining its characteristics.*

**AL = AL**

Da 3 lattine di alluminio si ottiene un paio di occhiali, da 37 lattine una caffettiera, da 70 lattine una padella, **da 200 un radiatore di design**, da 800 una bicicletta. L'alluminio riciclato permette di risparmiare 4 alberi per ogni tonnellata di alluminio prodotta.

*From 3 cans of aluminium we obtain a pair of glasses, from 37 cans a coffee machine, from 70 cans a pan, from 200 cans a designer radiator, from 800 a bicycle. Recycled aluminium allows to save 4 trees for each ton of aluminium.*



Nel mondo si producono ca. 60 milioni di ton/anno di alluminio. Ca. il 33% della quantità di alluminio prodotta è ricavata da rottami (alluminio secondario). Un albero con una vita media di 30 anni è in grado di riconvertire ca. 700 kg di CO<sub>2</sub>, per ogni tonnellata di alluminio prodotta da rottame si evita l'emissione in atmosfera di 2000 kg di CO<sub>2</sub>.

*Every year around 60 million tons of aluminium are produced worldwide. About 33% of the quantity of aluminium produced is extracted from scrap metal (secondary aluminium). A tree with an average life of 30 years is able to convert around 700 kg. of CO<sub>2</sub>. For each ton of aluminium produced from scrap metal, an emission of 2000 kg. of CO<sub>2</sub> can be avoided.*

Ogni tonnellata di alluminio prodotto da rottame produce ca. 200 kg di CO<sub>2</sub> contro i 900 kg di CO<sub>2</sub> prodotti riciclando l'acciaio.

*Each ton of aluminium produced from scrap metal generates around 200 kg. of CO<sub>2</sub> versus 900 kg. of CO<sub>2</sub> produced recycling steel.*

A parità di ingombro un radiatore realizzato in alluminio rende mediamente il 17% in più rispetto ad uno in acciaio.

*Taking into consideration the same size, a radiator made of aluminium is 17% more efficient than one made of steel.*

A parità di resa termica un radiatore in alluminio pesa mediamente la metà di uno in acciaio.

*With the same thermal efficiency, the weight of a radiator made of aluminium is half the weight of one made of steel.*

La flessibilità del radiatore realizzato in alluminio nel reagire alle diverse richieste termiche è doppia rispetto ad un radiatore realizzato in acciaio.

*The flexibility in terms of reaction to different thermal demands of a radiator made of aluminium is double when compared to a radiator made of steel.*

**MINORE QUANTITÀ D'ACQUA**

A parità di resa termica i radiatori in alluminio contengono una quantità d'acqua decisamente inferiore rispetto ai radiatori in acciaio o in ghisa, questo si traduce in tempi inferiori di riscaldamento e minore utilizzo della caldaia, **con conseguente riduzione dei costi energetici.**

**LESS QUANTITY OF WATER**

*On equal thermal efficiency the radiators made of aluminium contain a decisively lower quantity of water compared to radiators made of steel or cast iron. This means that the time necessary to heat is less with less use of a boiler **with a consequent reduction of energy costs.***

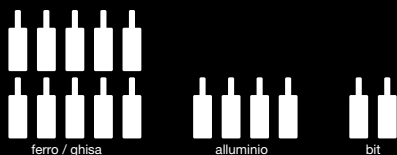

**ANCHE IL 20% DEI COSTI IN MENO**

Rispetto ai pannelli radianti, studi certificati hanno dimostrato che a parità di condizioni di funzionamento, gli impianti con pannelli radianti hanno un consumo energetico superiore ad un impianto realizzato con radiatori in alluminio. Il risparmio con i radiatori in alluminio arriva addirittura a un 20% quando la temperatura dei locali viene modificata durante la giornata.

**20% COSTS REDUCTION**

*Certified studies have demonstrated that on equal conditions of functioning, the systems with radiant panels have higher energy consumption if compared to aluminium radiators. With aluminium radiators energy savings reach up the 20% even when the temperature is modified during the whole day.*



Sottraendo una piccola porzione di superficie, Bit assume anche la funzione di portasalviette...

*Subtracting a small portion of its surface BIT turns into a towel holder...*

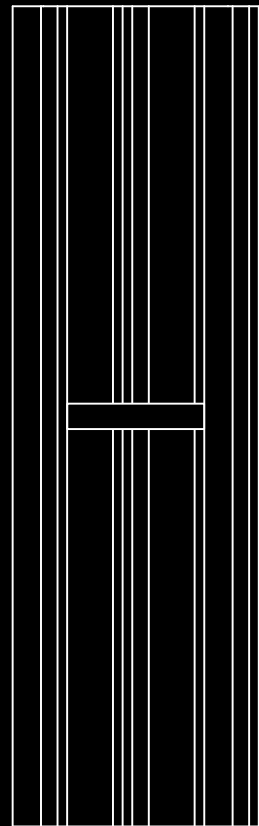
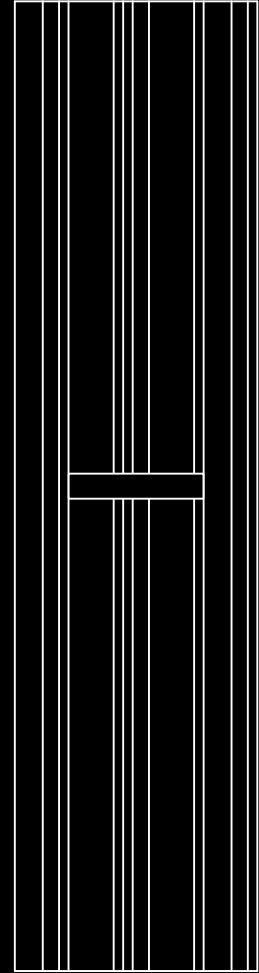
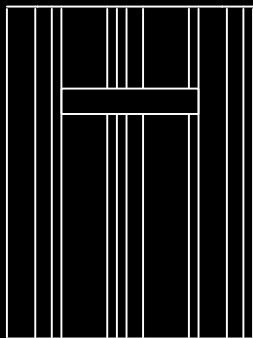
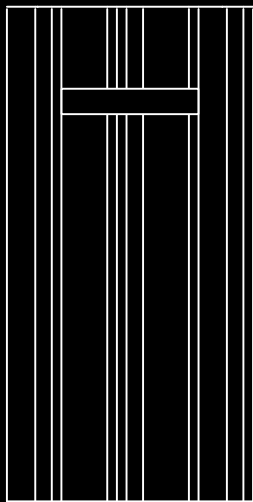
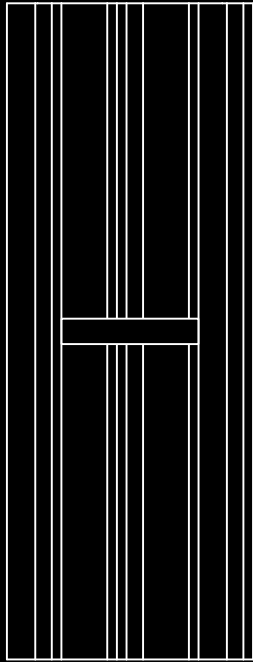

# BIT

## CARATTERISTICHE

BIT è un termoarredo sostenibile e sartoriale, con un alto grado di personalizzazione. È un trasformista, in grado di aggiungere alla primaria funzione del riscaldamento, altre sorprendenti funzioni.

## CHARACTERISTICS

BIT is a sustainable and versatile designer radiator, with a high degree of possible customization. It is a quick-change product which is able to add to its primary function of heating, other unexpected functions.

AMBIENTE  
ENVIRONMENT



SARTORIALITÀ  
TAILOR-MADE



COLORE  
COLOUR



ADDIZIONE  
ADDITION



SOTTRAZIONE  
SUBTRACTION



ROTAZIONE  
ROTATION



RIVOLUZIONE  
REVOLUTION



BIT design BRIAN SIRONI



- AMBIENTE
- SARTORIALITÀ
- COLORE
- ADDIZIONE
- SOTTRAZIONE
- ROTAZIONE
- RIVOLUZIONE (2014)



BIT



termoarredi  
designer radiators

BIT

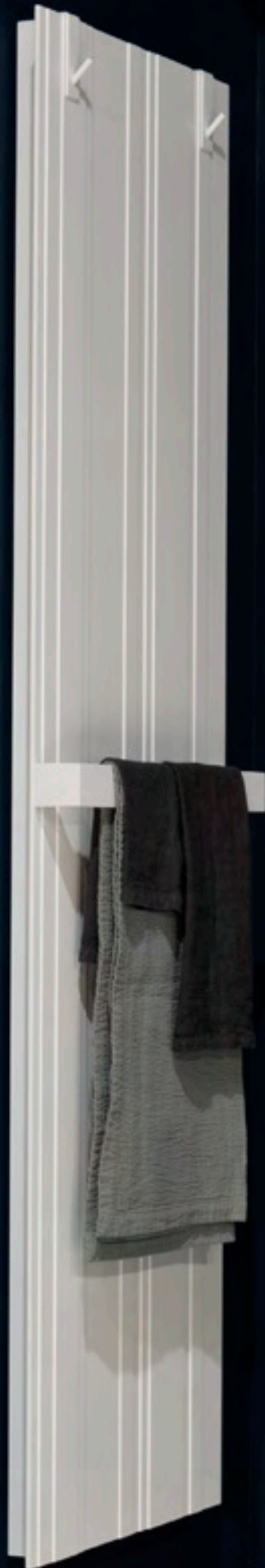





temoardi  
designer radiators

## BIT

Affiancando più elementi, Bit può diventare una boiserie per il bagno...  
*BIT could turn into a boiserie for the bathroom if more elements are pulled alongside...*





### 13 PUNTI DI FORZA DELL'ALLUMINIO IN RAFFRONTO ALL'ACCIAIO

- 1 BIT è un monolite realizzato al 100% in alluminio riciclato.
- 2 BIT è riciclabile all'infinito ( questo lo rende ecologico in quanto produrre una tonnellata di alluminio riciclato genera 0,1 tonnellate di CO<sub>2</sub> contro 1,9 tonnellate di CO<sub>2</sub> dell'acciaio riciclato ).
- 3 BIT pesa circa 1/3 rispetto al radiatore in acciaio ( a parità di dimensioni ).
- 4 BIT contiene 1 litro d'acqua per ogni kW termico generato, mentre mediamente un radiatore in acciaio necessita di 15 litri d'acqua per ogni kW termico generato ( riducendo la bolletta energetica ).
- 5 BIT ha la conducibilità termica 10 volte migliore dell'acciaio ( 22 contro 204 W/m°C ).
- 6 BIT a parità di forma e dimensione rende mediamente il 17% in più rispetto ad uno in acciaio.
- 7 BIT e' realizzato in un singolo pezzo a differenza del radiatore in acciaio realizzato saldando piu' elementi.
- 8 BIT non avendo saldature non ha residui e scorie tipiche dell'acciaio che sono causa di ostruzioni nelle caldaie e nel circuito idraulico.
- 9 BIT, a differenza dei radiatori in acciaio, non arrugginisce.
- 10 BIT ha una vita molto piu' lunga grazie allo spessore del passaggio dell'acqua di 6 mm contro lo spessore dell'acciaio di circa 1 mm.
- 11 BIT con il suo spessore importante permette l'utilizzo in circuiti ad elevata pressione anche fino a 16 atmosfere contro le 6 del normale radiatore in acciaio.
- 12 BIT ha tempi ridotti di riscaldamento a Messa a Regime ( da 5°C a 21°C ):
  - alluminio 48 min
  - acciaio o ghisa 78 min
- 13 BIT si adatta ad impianti idraulici monotubo o bitubo.

### THE 13 ADVANTAGES OF ALUMINIUM IF COMPARED TO STEEL

- 1 BIT is monolithic made of 100% recycled aluminium.
- 2 BIT can be recycled perpetually (this means that BIT is sustainable, a ton of recycled aluminium generates 0,1 ton of CO<sub>2</sub> against 1,9 tons of CO<sub>2</sub> produced by steel).
- 3 BIT weighs one third if compared to steel ( given the same size ).
- 4 BIT contains 1 litre of water for each generated thermal kW, while a steel radiator needs on average 15 litres of water for each generated thermal kW ( thus, energy bills are reduced ).
- 5 BIT has a thermal conductivity 10 times better than steel ( 22 against 204 W/m°C ).
- 6 BIT is 17% more efficient than a radiator of the same shape and same size made of steel.
- 7 BIT is made of a single block instead of being composed of various elements welded together like steel radiators.
- 8 BIT does not have welded parts and therefore it does not produce residuals typical of steel. Residuals are the cause of obstructions of boilers and plumbing systems.
- 9 BIT, in opposition to steel radiators, does not rust.
- 10 BIT has a longer life thanks to the thickness of channels where water circulates (6 mm) against the size of channels of steel radiators which are usually less than 1 mm.
- 11 BIT, thanks to its thickness, allows the use of high pressure circuits up to 16 Atmospheres against 6 of standard steel radiators.
- 12 BIT becomes fully operational heating in a short time ( from 5°C to 21°C ):
  - Aluminium 48 min
  - Steel or cast iron 78 min
- 13 BIT can be used both with single and double pipe water systems.

Ruotandolo di 90° Bit diviene una striscia orizzontale...  
Rotating of 90° BIT becomes horizontal...



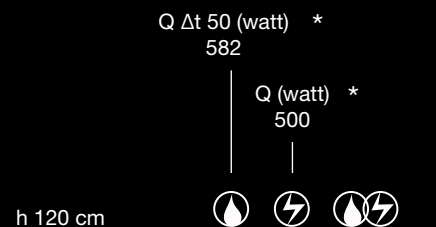
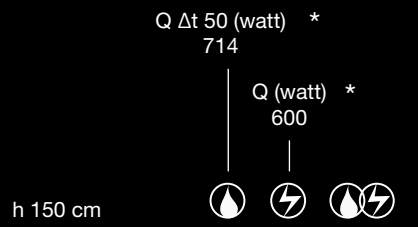
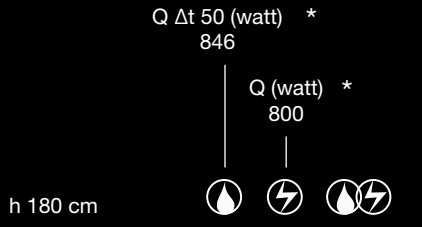

BIT non è un semplice monolite, si potrebbe definire come una matrice che può generare un numero di pezzi infinito: un unico estruso che può essere tagliato ad altezze diverse. Un termoarredo sartoriale, realizzabile su misura.

*BIT is not a simple monolith, it can be defined as a matrix that virtually generates an infinite number of pieces: a single extrusion that can be cut at different heights. An interior furnishing radiator that can be customized.*





















 versione ad acqua  
water version

 versione elettrica  
electrical version

 versione mista acqua / elettrica  
combined water / electric version

ART.	Versione Version	Dimensioni LxH (cm) Dimensions LxH (cm)	Interasse (cm) Centre to centre distance (cm)	Peso (kg) Weight (kg)	Volume d'acqua (kg) Water content (kg)	Q Δt 50 (watt) Q Δt 50 (watt)	Q Δt 30 (watt)* Q Δt 30 (watt)	Q versione elettrica (watt) Q electric version
BIT60A		45 x 60	5	10,8	0,34	313,30	167,40	
BIT90A		45 x 90	5	16,2	0,51	449,15	234,53	
BIT120A		45 x 120	5	21,6	0,68	582,18	303,22	
BIT150A		45 x 150	5	27	0,85	714,09	373,25	
BIT180A		45 x 180	5	32,4	1,02	845,82	443,92	
BIT45E		45 x 45		8,1				200
BIT60E		45 x 60		10,8				300
BIT90E		45 x 90		16,2				400
BIT120E		45 x 120		21,6				500
BIT150E		45 x 150		27				600
BIT180E		45 x 180		32,4				800
BIT60AE		45 x 60	5	10,8	0,34	313,30	167,40	300
BIT90AE		45 x 90	5	16,2	0,51	449,15	234,53	400
BIT120AE		45 x 120	5	21,6	0,68	582,18	303,22	500
BIT150AE		45 x 150	5	27	0,85	714,09	373,25	600
BIT180AE		45 x 180	5	32,4	1,02	845,82	443,92	800

\* VALORI INDICATIVI - APPROXIMATE VALUES

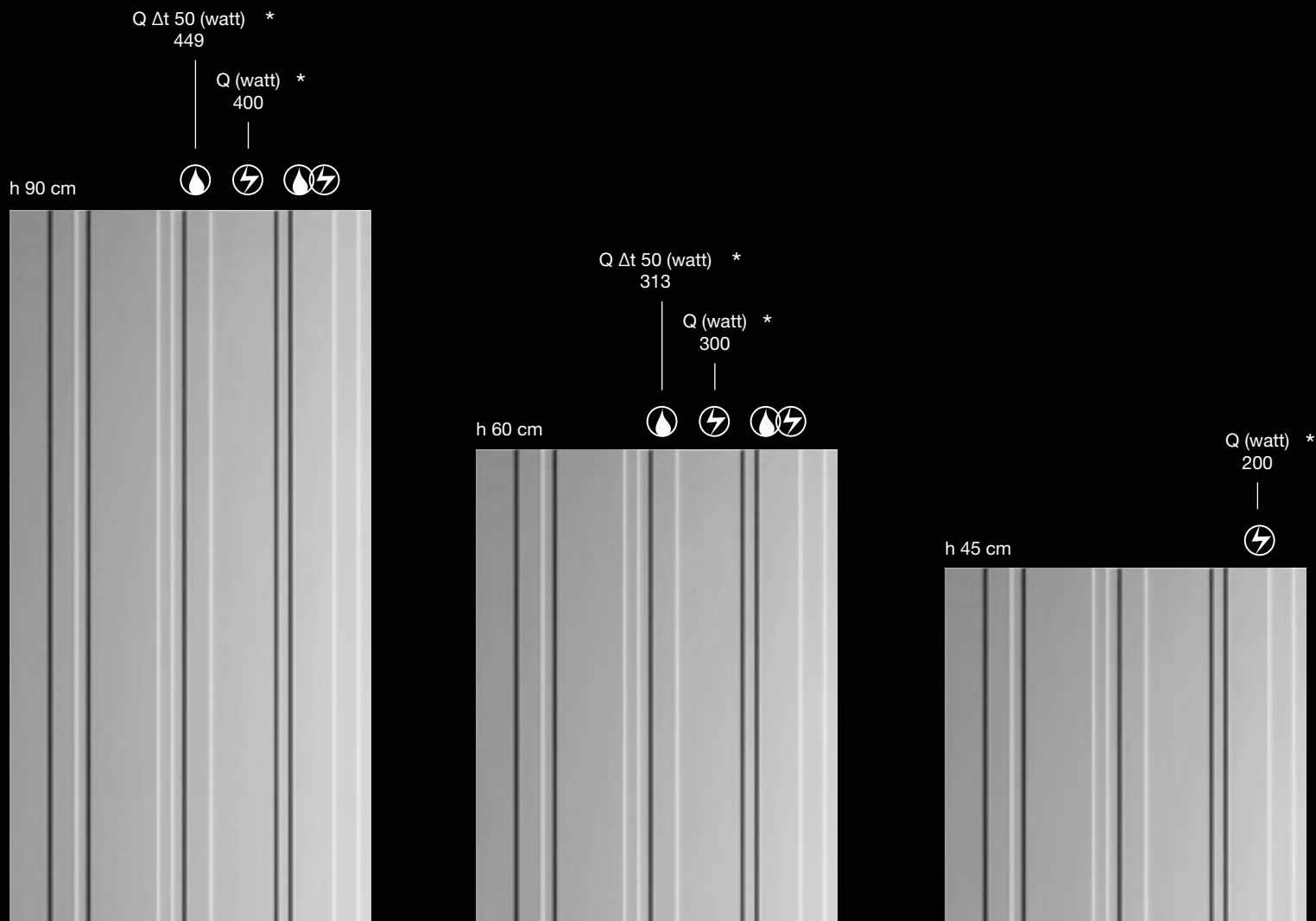

## BIT

I termoarredi nella versione bianco opaco (RAL 9010) possono essere personalizzati con l'utilizzo di vernici quali:

- smalto al solvente satinato, antigraffio e anticorrosivo.

- smalto ad acqua antigraffio.

I termoarredi nella versione colorato gofrato sono verniciati come da nostra cartella colori mobili.

*Designer radiators in matt white finishing (RAL 9010) can be customized using paintings like:*

*- satin solvent-based lacquer, anti-scratch and anticorrosive.*

*- anti-scratch water-based lacquer.*

*Designer radiators in embossed lacquered version can be painted as per our furniture colour chart.*







versione ad acqua - water version



versione elettrica - electrical version



versione mista acqua/elettrica  
combined water/electric version

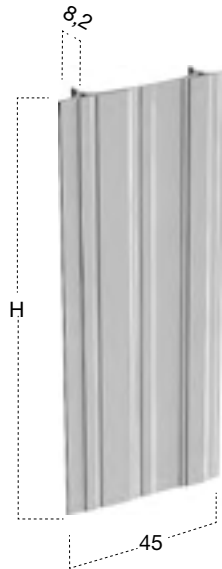

Termoarredo in alluminio versione ad acqua.

*Aluminium designer radiator, water version.*

H	P	L	art.
60	8,2	45	<b>BIT60A</b>
90			<b>BIT90A</b>
120			<b>BIT120A</b>
150			<b>BIT150A</b>
180			<b>BIT180A</b>

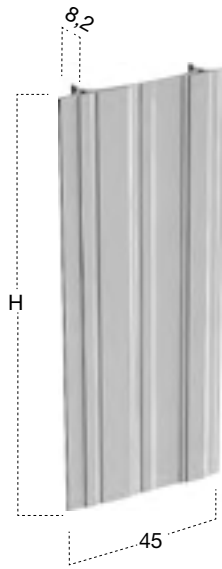

Termoarredo in alluminio versione elettrica.

*Aluminium designer radiator, electric version.*

H	P	L	art.
45	8,2	45	<b>BIT45E</b>
60			<b>BIT60E</b>
90			<b>BIT90E</b>
120			<b>BIT120E</b>
150			<b>BIT150E</b>
180			<b>BIT180E</b>

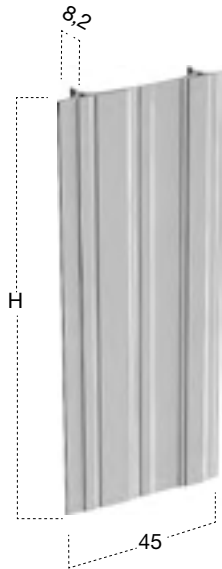

Termoarredo in alluminio versione mista acqua/elettrica.

*Aluminium designer radiator, combined water/electric version.*

H	P	L	art.
60	8,2	45	<b>BIT60AE</b>
90			<b>BIT90AE</b>
120			<b>BIT120AE</b>
150			<b>BIT150AE</b>
180			<b>BIT180AE</b>





## BITBARRA design Brian Sironi

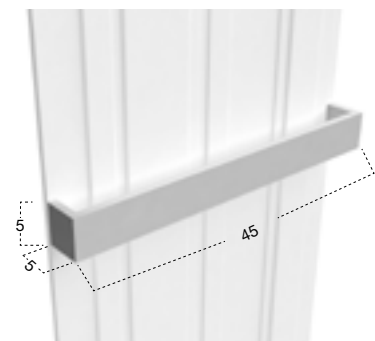

Porta salviette per termoarredo in acciaio inox satinato AISI 304 o colorato gofrato come da nostra cartella colori laccati.

*Towel holder for radiator in satin stainless steel AISI 304 or lacquered embossed as per our colour chart.*

H	P	L	art.
5	5	45	<b>BITBARRA</b>

termoarredi  
designer radiators

## BITGANCIO design Brian Sironi

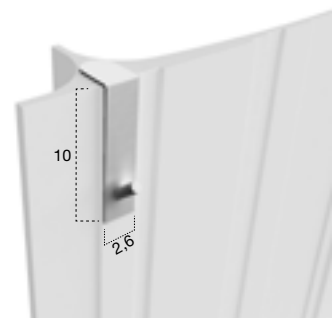

Appendi abiti per termoarredo in acciaio inox satinato AISI 304 o colorato gofrato come da nostra cartella colori laccati.

*Clothes hook for radiators in satin stainless steel AISI 304 or lacquered embossed as per our colour chart.*

H	L	art.
10	2,6	<b>BITGANCIO</b>

# BIT

Termoarredo in alluminio versione ad acqua con altezza H a misura.

*Aluminium designer radiator, water version, with custom height H.*

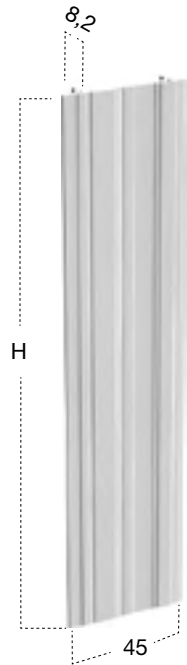

H	P	L	art.
61/149	8,2	45	<b>BIT1A</b>
151/200			<b>BIT2A</b>
201/300			<b>BIT3A</b>

Taglio portasalviette, posizione standard.

*Towel holder cut, standard position.*

art.

**TAGLIOS**

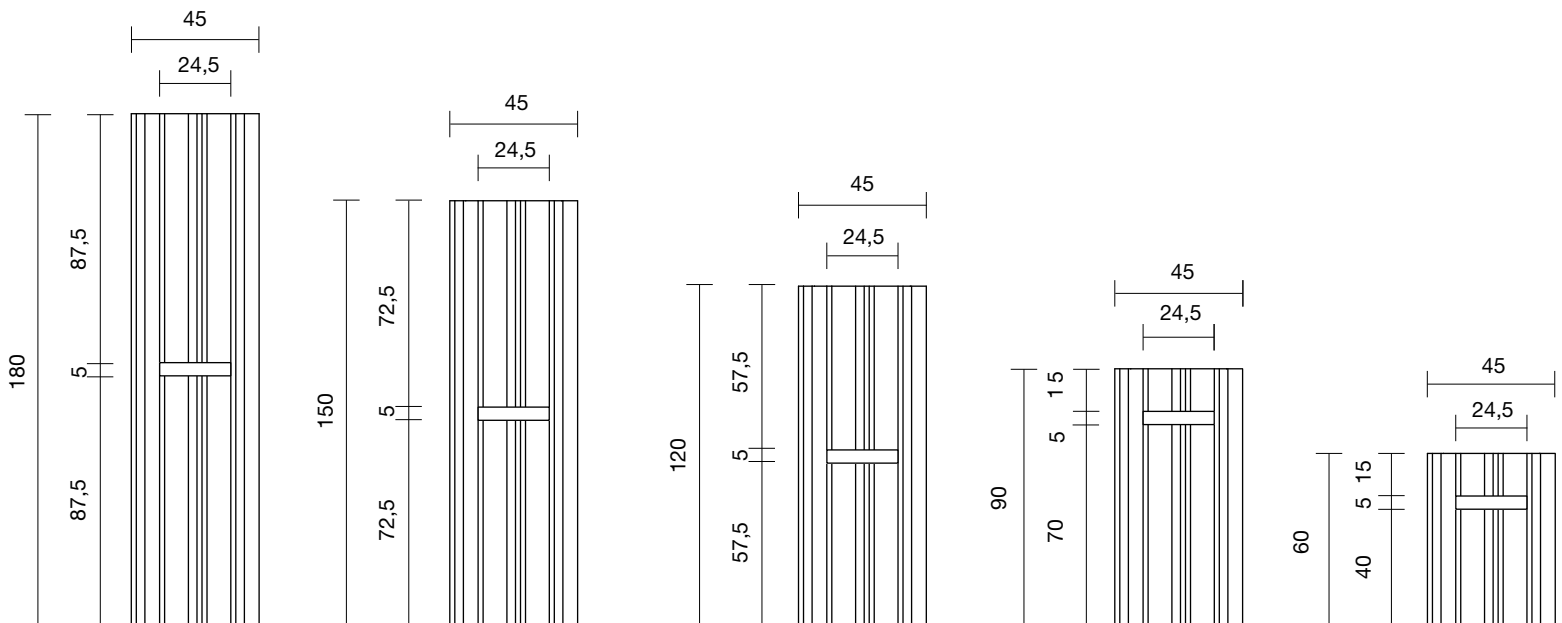





Possibili tagli per portasalviette fuori posizione standard.

*Possible towel holder cuts in special position.*

art.  
**TAGLIOM**

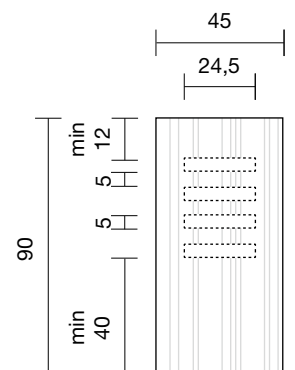
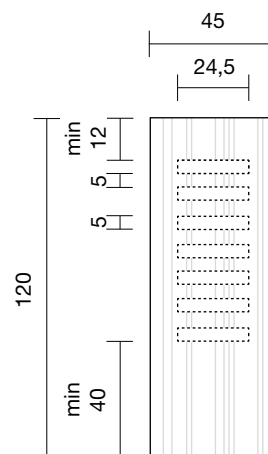
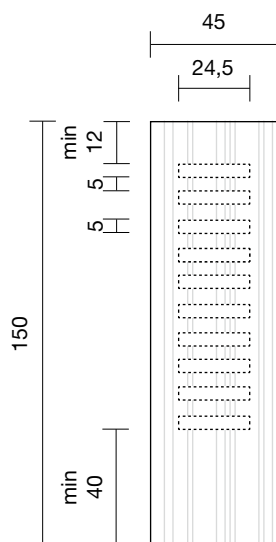
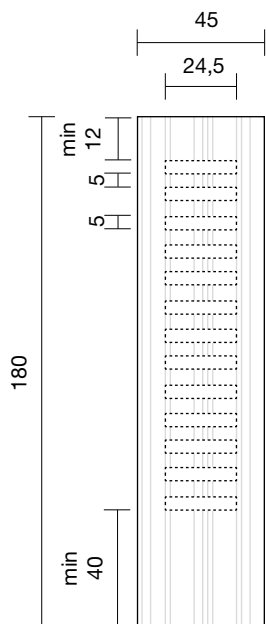





**PENSILI E COMPLEMENTI D'ARREDO**  
**WALL CABINETS AND FURNISHINGS**



*pensili e complementi d'arredo*  
*wall cabinets and furnishings*







pensili e complementi d'arredo  
wall cabinets and furnishings

P	L	art.
14	27	<b>ICE4</b>
	45	<b>ICE5</b>
	72	<b>ICE6</b>

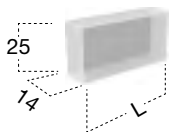

Pensile a giorno in cristallo extrachiario a 1 vano con schienale verniciato come da nostra cartella colori laccati.

*Open wall cabinet in extra-clear glass with 1 compartment and back panel lacquered as per our colour chart.*





# ICE



pensili e complementi d'arredo  
wall cabinets and furnishings

art. ICE7

art. ICE8

art. ICE1

art. ICE2

art. ICE3

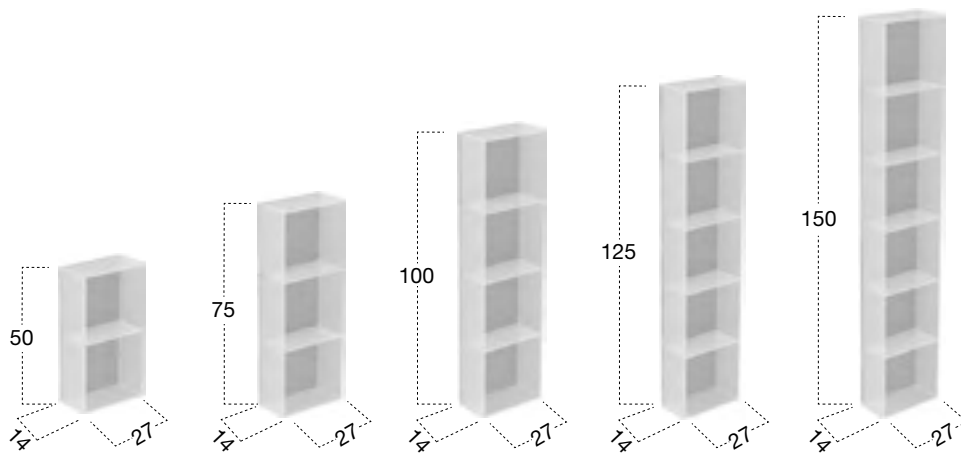

Pensili e colonne a giorno in cristallo extrachiaro a 2, 3, 4, 5 e 6 vani con schienale verniciato come da nostra cartella colori laccati.

*Open wall cabinets in extra-clear glass with 2, 3, 4, 5 and 6 compartments and back panel lacquered as per our colour chart.*





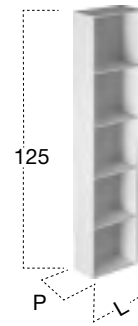
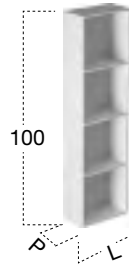

P	L	art.
14	27	<b>PC827</b>
	36	<b>PC836</b>
	45	<b>PC845</b>
	54	<b>PC854</b>
22	27	<b>PC2027</b>
	36	<b>PC2036</b>
	45	<b>PC2045</b>
	54	<b>PC2054</b>
32	27	<b>MC10</b>
	36	<b>MC11</b>
	45	<b>MC12</b>
	54	<b>MC13</b>

P	L	art.
14	27	<b>PC2427</b>
	36	<b>PC2436</b>
	45	<b>PC2445</b>
	54	<b>PC2454</b>
22	27	<b>PC2127</b>
	36	<b>PC2136</b>
	45	<b>PC2145</b>
	54	<b>PC2154</b>

pensili e complementi d'arredo  
wall cabinets and furnishings

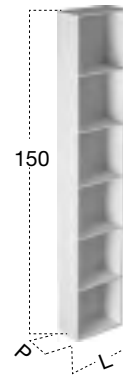

P	L	art.
14	27	<b>PC327</b>
	36	<b>PC336</b>
	45	<b>PC345</b>
	54	<b>PC354</b>
22	27	<b>PC2227</b>
	36	<b>PC2236</b>
	45	<b>PC2245</b>
	54	<b>PC2254</b>
32	27	<b>MC14</b>
	36	<b>MC15</b>
	45	<b>MC16</b>
	54	<b>MC17</b>

P	L	art.
14	27	<b>PC2527</b>
	36	<b>PC2536</b>
	45	<b>PC2545</b>
	54	<b>PC2554</b>
22	27	<b>PC2327</b>
	36	<b>PC2336</b>
	45	<b>PC2345</b>
	54	<b>PC2354</b>

Colonne a giorno a 4, 5, 6 e 7 vani.  
Open high cabinets with 4, 5, 6 and 7 compartments.





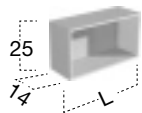

Pensile a giorno a 1 vano.  
Open wall cabinet with 1 compartment.

P	L	art.
14	27	<b>PE227</b>
	36	<b>PE236</b>
	45	<b>PE245</b>
	54	<b>PE254</b>
	63	<b>PE263</b>

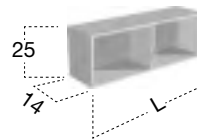

Pensile a giorno a 2 vani.  
Open wall cabinet with 2 compartments.

P	L	art.
14	72	<b>PE372</b>
	90	<b>PE390</b>
	108	<b>PE3108</b>

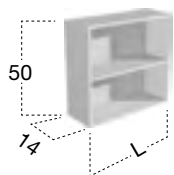

Pensile a giorno a 2 vani.  
Open wall cabinet with 2 compartments.

P	L	art.
14	27	<b>PE427</b>
	36	<b>PE436</b>
	45	<b>PE445</b>
	54	<b>PE454</b>
	63	<b>PE463</b>

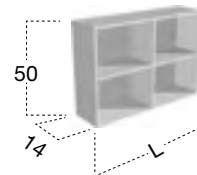

Pensile a giorno a 4 vani.  
Open wall cabinet with 4 compartments.

P	L	art.
14	72	<b>PE572</b>
	90	<b>PE590</b>
	108	<b>PE5108</b>





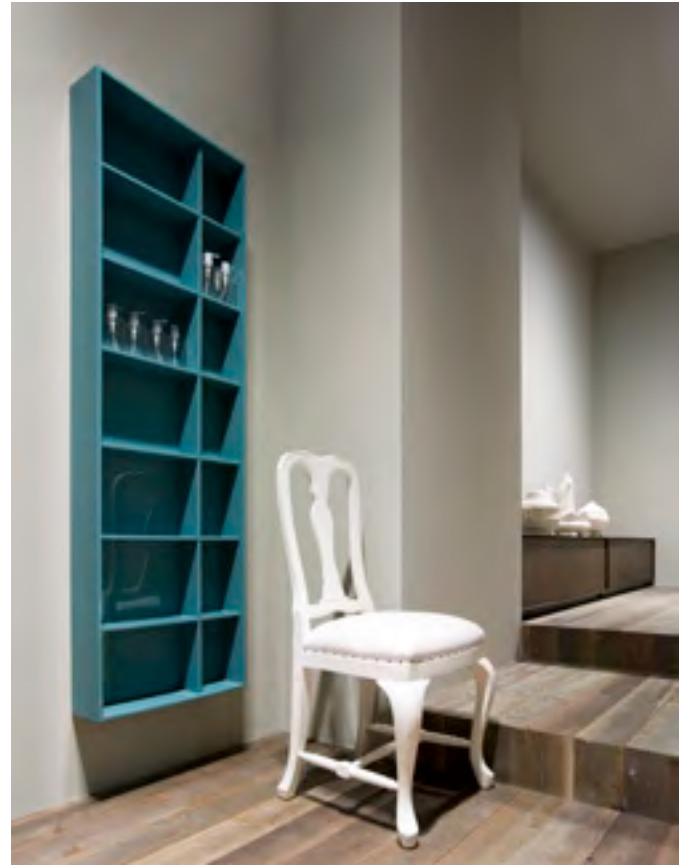

pensili e complementi d'arredo  
wall cabinets and furnishings

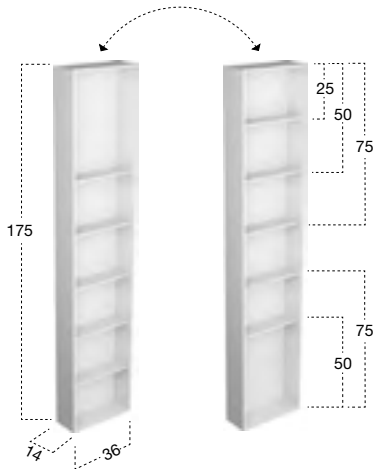

P L art.  
14 36 LC1036

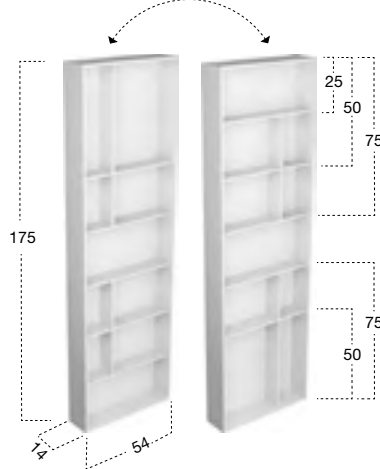

P L art.  
14 54 LC1254

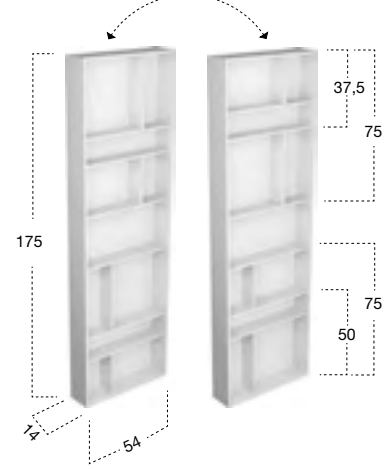

P L art.  
14 54 LC1354

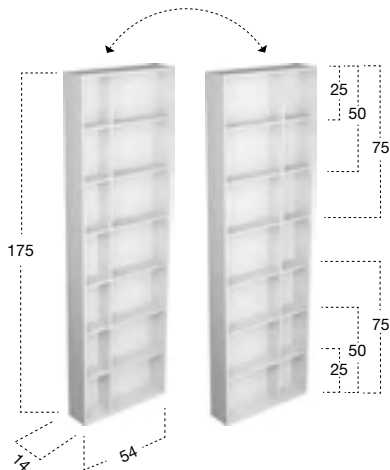

P L art.  
14 54 LC1454

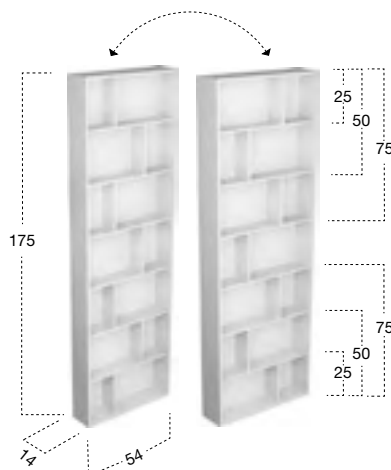

P L art.  
14 54 LC1554

Colonne a giorno reversibili a 6, 10, 11 e 14 vani.  
Reversible open high cabinets with 6, 10, 11 and 14 compartments.







pensili e complementi d'arredo  
wall cabinets and furnishings

Art. **FLESSO10014** P 14  
Art. **FLESSO10022** P 22

Art. **FLESSO15014** P 14  
Art. **FLESSO15022** P 22

Art. **FLESSO17514** P 14  
Art. **FLESSO17522** P 22

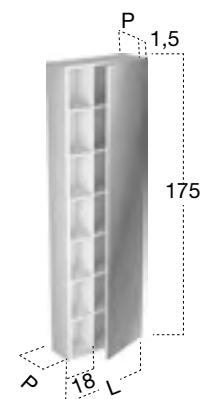
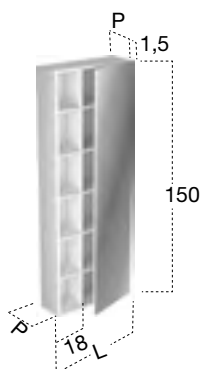
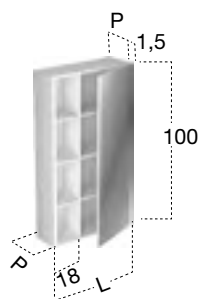
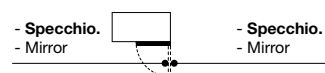
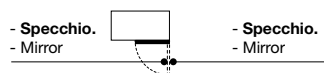

P	L
14	45 (27+18) 54 (36+18)
22	45 (27+18) 54 (36+18)

P	L
14	45 (27+18) 54 (36+18)
22	45 (27+18) 54 (36+18)

P	L
14	45 (27+18) 54 (36+18)
22	45 (27+18) 54 (36+18)

Pensile dx o sx con 1 anta a specchio bifacciale e 3, 5 o 6 ripiani interni e un divisorio interno.  
Right or left wall cabinet with double faced mirrored door and 3, 5 or 6 internal shelves and 1 divider.







pensili e complementi d'arredo  
wall cabinets and furnishings

art. NOMADE11

art. NOMADE12

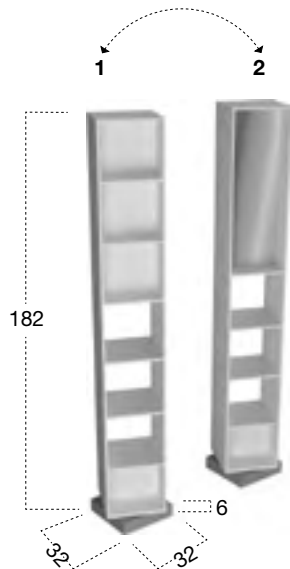
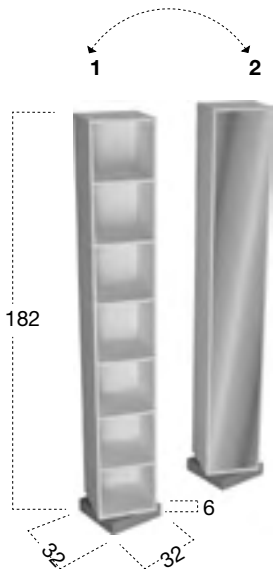

**art.  
NOMADE11**

Colonna girevole su base in pietra Cardoso con fronte (1) a 7 vani a giorno e retro (2) a specchio.

*Revolving high cabinet with a Cardoso stone base with side (1) 7 open compartments and side (2) mirror.*

**art.  
NOMADE12**

Colonna girevole su base in pietra Cardoso con fronte (1) a 4 vani a giorno chiusi, 3 vani a giorno aperti e retro (2) a 1 vano a specchio, 3 vani aperti e 1 vano chiuso.

*Revolving high cabinet with a Cardoso stone base with side (1) 4 closed compartments, 3 open compartments and side (2) 1 mirror, 3 open compartments and 1 closed compartment.*

**PENSILI E COLONNE IN CRISTALLO - GLASS WALL AND HIGH CABINETS**

Colonna a giorno in cristallo extrachiaro a 6 vani con schienale verniciato come da nostra cartella colori laccati.  
*Open wall cabinet in extra-clear glass with 6 compartments and back panel lacquered as per our colour chart.*











Colonna a giorno in cristallo extrachiaro a 5 vani con schienale verniciato come da nostra cartella colori laccati.  
*Open wall cabinet in extra-clear glass with 5 compartments and back panel lacquered as per our colour chart.*

Colonna a giorno in cristallo extrachiaro a 4 vani con schienale verniciato come da nostra cartella colori laccati.  
*Open wall cabinet in extra-clear glass with 4 compartments and back panel lacquered as per our colour chart.*

Pensile a giorno in cristallo extrachiaro a 3 vani con schienale verniciato come da nostra cartella colori laccati.  
*Open wall cabinet in extra-clear glass with 3 compartments and back panel lacquered as per our colour chart.*

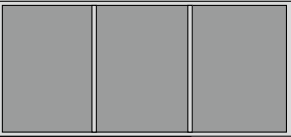
Pensile a giorno in cristallo extrachiaro a 2 vani con schienale verniciato come da nostra cartella colori laccati.  
*Open wall cabinet in extra-clear glass with 2 compartments and back panel lacquered as per our colour chart.*

Pensile a giorno in cristallo extrachiaro a 1 vano con schienale verniciato come da nostra cartella colori laccati.  
*Open wall cabinet in extra-clear glass with 1 compartment and back panel lacquered as per our colour chart.*

		L	ART	27	ICE3
		L	ART	27	ICE2
		L	ART	27	ICE1
		L	ART	27	ICE8
		L	ART	27	ICE7
		L	ART	27 45 72	ICE4 ICE5 ICE6
				P 14	
				25	
				50	
				75	
				100	
				125	
				150	







**PENSILI IN LEGNO - WOOD WALL CABINETS**

Pensile a giorno a 4 vani.  
*Open wall cabinet with 4 compartments.*

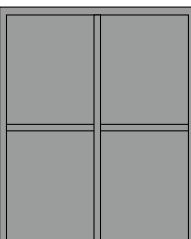
Pensile a giorno a 2 vani.  
*Open wall cabinet with 2 compartments.*

Pensile a giorno a 2 vani.  
*Open wall cabinet with 2 compartments.*

Pensile a giorno a 1 vano.  
*Open wall cabinet with 1 compartment.*

		L	ART	72 90 108	PE572 PE590 PE5108
		L	ART	27 36 45 54 63	PE427 PE436 PE445 PE454 PE463
		L	ART	72 90 108	PE372 PE390 PE3108
		L	ART	27 36 45 54 63	PE227 PE236 PE245 PE254 PE263
				P 14	
				25	
				50	



**PENSILI E COLONNE IN LEGNO - WOOD WALL AND HIGH CABINETS**

Pensile dx o sx con 1 anta a specchio bifacciale, 6 ripiani interni e 1 divisorio.  
*Right or left wall cabinet with double faced mirrored door, 6 internal shelves and 1 divider.*

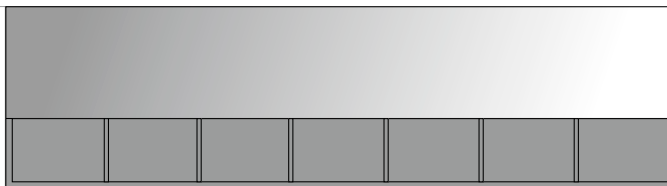
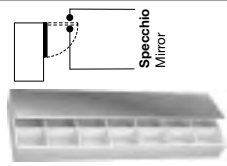

art. FLESSO17514	L	45	54	art. FLESSO17522	L	45	54
------------------	---	----	----	------------------	---	----	----

Pensile dx o sx con 1 anta a specchio bifacciale, 5 ripiani interni e 1 divisorio.  
*Right or left wall cabinet with double faced mirrored door, 5 internal shelves and 1 divider.*

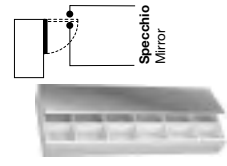

art. FLESSO15014	L	45	54	art. FLESSO15022	L	45	54
------------------	---	----	----	------------------	---	----	----

Pensile dx o sx con 1 anta a specchio bifacciale, 3 ripiani interni e 1 divisorio.  
*Right or left wall cabinet with double faced mirrored door, 3 internal shelves and 1 divider.*

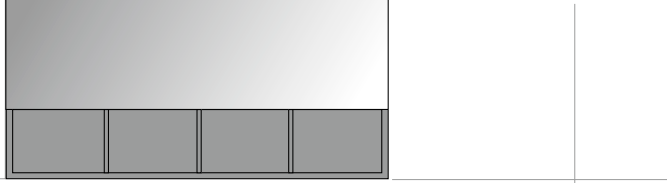
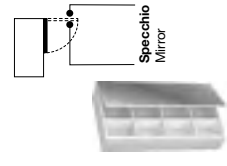

art. FLESSO10014	L	45	54	art. FLESSO10022	L	45	54
------------------	---	----	----	------------------	---	----	----

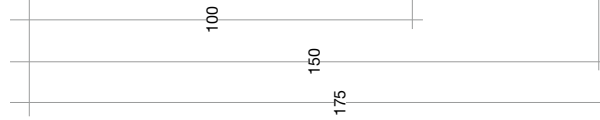

Colonna a giorno reversibile a 14 vani.  
*Reversible open high cabinet with 14 compartments.*

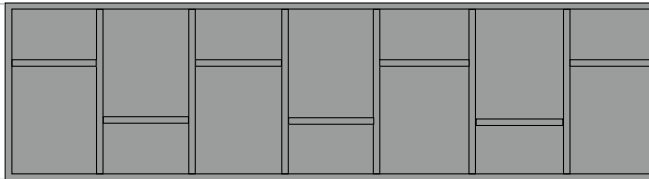
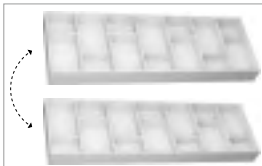

L	ART	54	LC1554
---	-----	----	--------

Colonna a giorno reversibile a 14 vani.  
*Reversible open high cabinet with 14 compartments.*

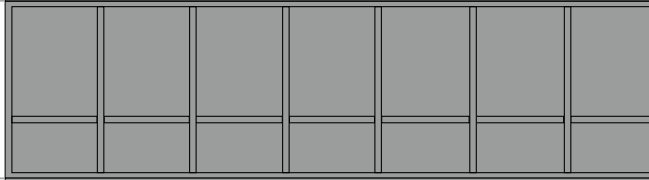

L	ART	54	LC1454
---	-----	----	--------

Colonna a giorno reversibile a 11 vani.  
*Reversible open high cabinet with 11 compartments.*

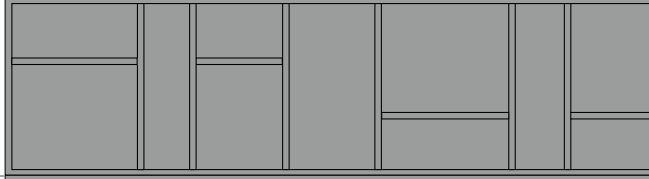

L	ART	54	LC1354
---	-----	----	--------

Colonna a giorno reversibile a 10 vani.  
*Reversible open high cabinet with 10 compartments.*

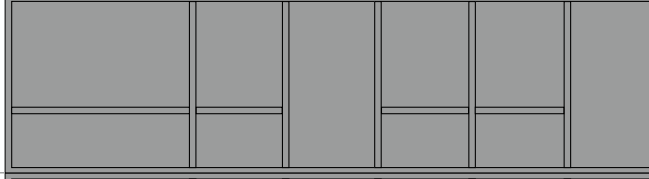

L	ART	54	LC1254
---	-----	----	--------

Colonna a giorno reversibile a 6 vani.  
*Reversible open high cabinet with 6 compartments.*



L	ART	36	LC1036
---	-----	----	--------

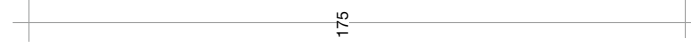

pensili e complementi d'arredo  
 wall cabinets and furnishings

**PENSILI E COLONNE IN LEGNO - WOOD WALL AND HIGH CABINETS**

Colonna a giorno a 7 vani. Open high cabinet with 7 compartments.			L ART	27 PC2527	36 PC2536	45 PC2545	54 PC2554	27 PC2327	36 PC2336	45 PC2345	54 PC2354
Colonna a giorno a 6 vani. Open high cabinet with 6 compartments.			L ART	27 PC327	36 PC336	45 PC345	54 PC354	27 PC2227	36 PC2236	45 PC2245	54 PC2254
Colonna a giorno a 5 vani. Open high cabinet with 5 compartments.			L ART	27 PC2427	36 PC2436	45 PC2445	54 PC2454	27 PC2127	36 PC2136	45 PC2145	54 PC2154
Colonna a giorno a 4 vani. Open high cabinet with 4 compartments.			L ART	27 PC827	36 PC836	45 PC845	54 PC854	27 PC2027	36 PC2036	45 PC2045	54 PC2054
			P 14					P 22			
											P 32

Colonna dx o sx con anta a specchio bifacciale, 5 ripiani e 1 divisorio.  
Right or left high cabinet with double faced mirror door, 5 internal shelves and 1 divider.

Colonna dx o sx con 1 anta, 5 ripiani e 1 divisorio.  
Right or left single door high cabinet with 5 internal shelves and 1 divider.

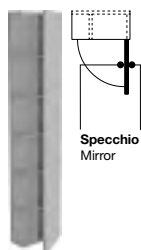

Specchio  
Mirror

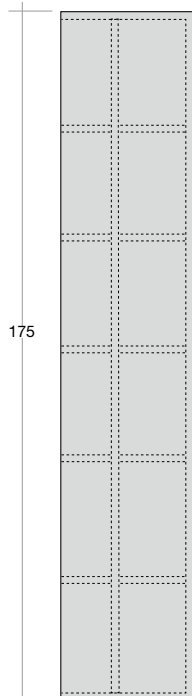
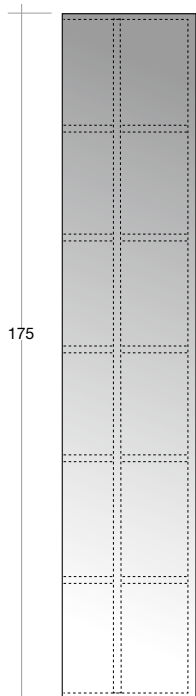

art. GIANO

L

P 19

36

art. PC636

L

P 20

36





pensili e complementi d'arredo  
wall cabinets and furnishings







LIBRERIE / BOOKCASES



librerie  
bookcases



**CITY** design Carlo Colombo

**Modello e design registrato, brevetto depositato**  
*Registered model and design, patent filed*







librerie  
bookcases







CITY



librerie  
bookcases

# CITY

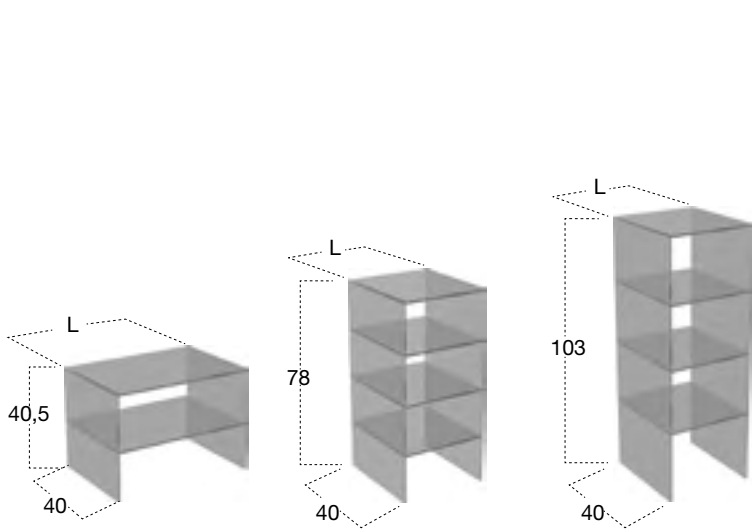

H	L	art.	H	L	art.	H	L	art.
40,5	54	<b>CITY1054</b>	78	27	<b>CITY2027</b>	103	27	<b>CITY3027</b>
	72	<b>CITY1072</b>		36	<b>CITY2036</b>		36	<b>CITY3036</b>
				45	<b>CITY2045</b>		45	<b>CITY3045</b>
				54	<b>CITY2054</b>		54	<b>CITY3054</b>

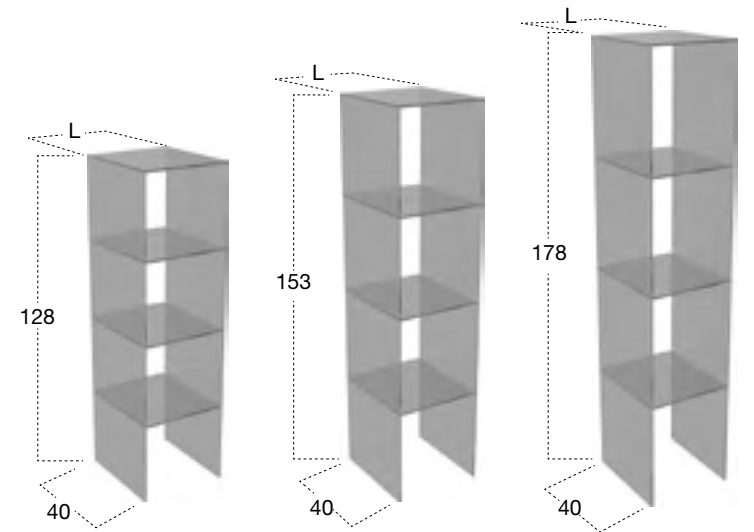

H	L	art.	H	L	art.	H	L	art.
128	27	<b>CITY4027</b>	153	27	<b>CITY5027</b>	178	27	<b>CITY6027</b>
	36	<b>CITY4036</b>		36	<b>CITY5036</b>		36	<b>CITY6036</b>
	45	<b>CITY4045</b>						
	54	<b>CITY4054</b>						

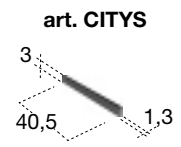

art. CITYS  
 Piede singolo in acciaio AISI 304.  
 Single steel foot in AISI 304.

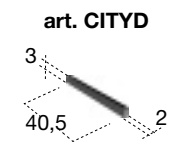

art. CITYD  
 Piede doppio in acciaio AISI 304.  
 Double steel foot in AISI 304.

Colonne a giorno in cristallo extrachiario.  
 Extra-clear glass display cabinet.



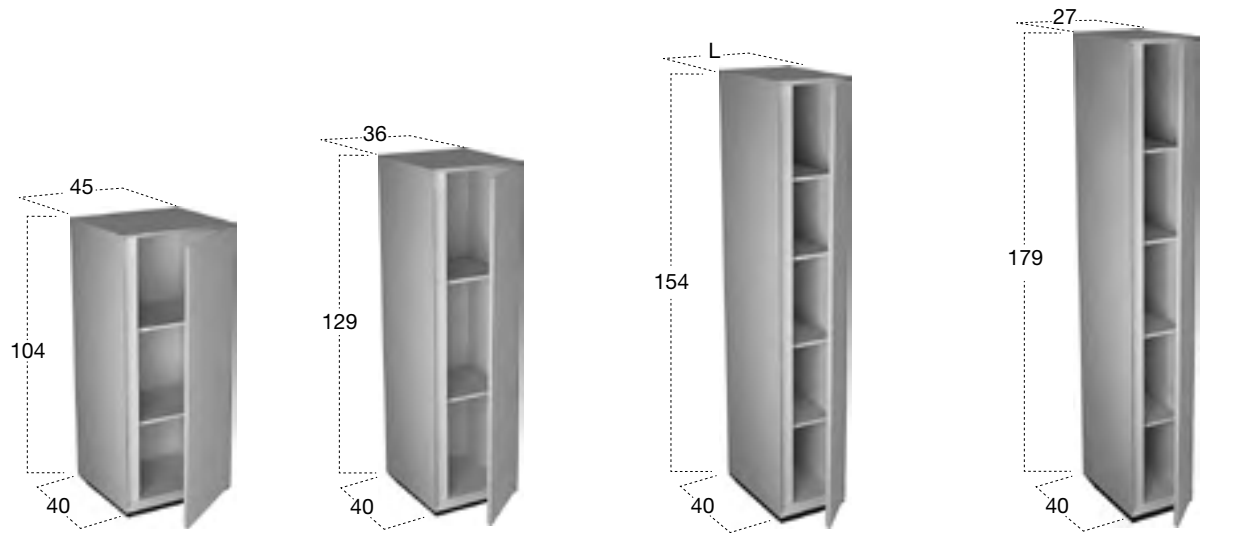

**VERSIONE CON 1 ANTA**  
Version with 1 door

H L art.  
104 45 **PC1645**

H L art.  
129 36 **PC1736**

H L art.  
154 27 **PC1827**  
36 **PC1836**

H L art.  
179 27 **PC1927**

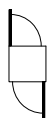

**VERSIONE CON 2 ANTE**  
Version with 2 doors

H L art.  
104 45 **PC1245**

H L art.  
129 36 **PC1336**

H L art.  
154 27 **PC1427**  
36 **PC1436**

H L art.  
179 27 **PC1527**

Colonna con 1 o 2 ante (1 posteriore e 1 anteriore) dx o sx e ripiani interni in legno, completa di zoccolo nero goffrato, H 4 cm.

Cabinet with 1 or 2 doors (front and back) right or left and internal shelves, complete with plinth lacquered embossed black, H 4 cms.





**SANITARI / SANITARY-WARE**



sanitari  
sanitary-ware



art. KOMODO1/KOMODO3

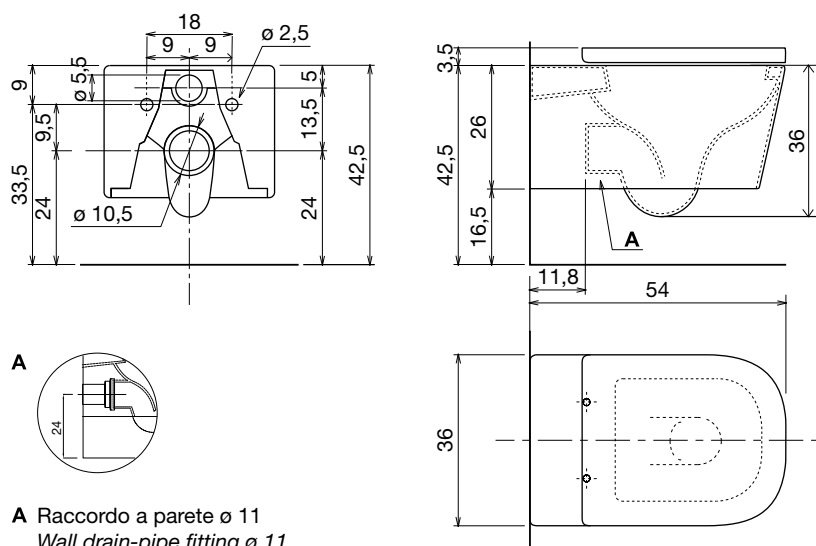

Vaso in ceramica lucida (art. KOMODO1) o satinata (art. KOMODO3), sospeso con scarico a parete, completo di sedile avvolgente estraibile realizzato in resina termoindurente con cerniera frizionata sistema "soft-close".

*Polished (art. KOMODO1) or satin (art. KOMODO3) glazed suspended ceramic water closet complete with removable toilet seat cover made of thermosetting resin and "soft-close" system hinge.*



# KOMODO



art. KOMODO2/KOMODO4

Schemi scarichi bidet "KOMODO2", "KOMODO4", con sifone "MICRO".  
 Technical drawing for drainage bidet "KOMODO2", "KOMODO4", with trap "MICRO".

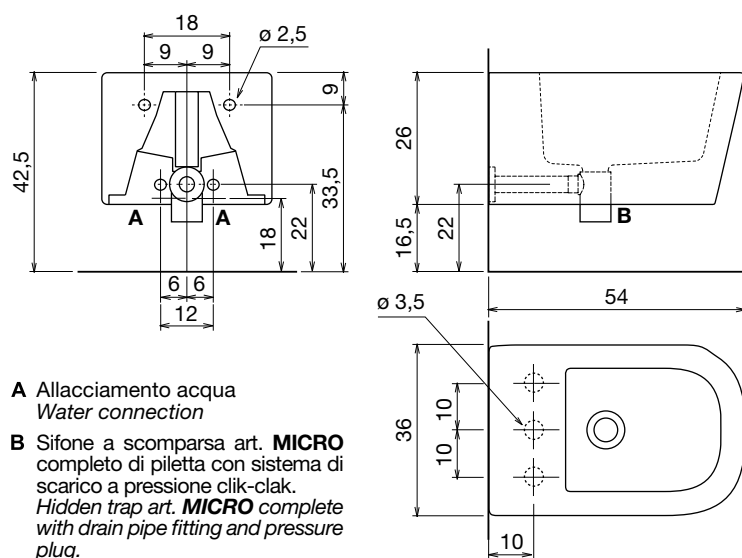

Schemi scarichi bidet "KOMODO2", "KOMODO4".  
 Technical drawing for drainage bidet "KOMODO2", "KOMODO4".

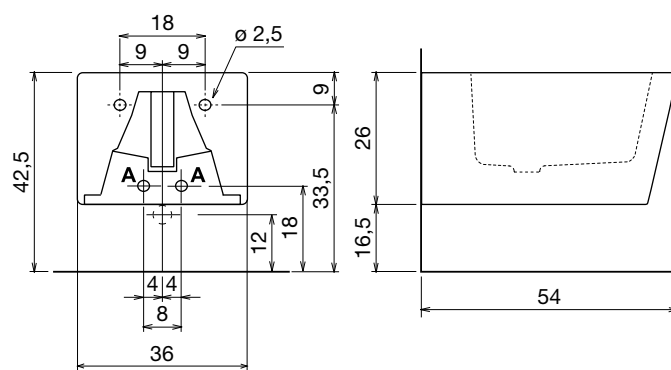

Bidet monoforo in ceramica lucida (art. KOMODO2) o satinata  
 (art. KOMODO4), sospeso con scarico a parete.

Polished (art. KOMODO2) or satin glazed (art. KOMODO4)  
 suspended ceramic bidet with wall drainage and single tap hole.





KOMODO



sanitari  
sanitary-ware







sanitari  
sanitary-ware



# SELLA



art. SELLA1

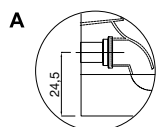
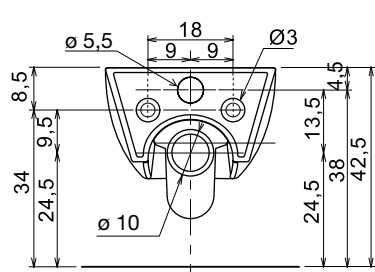

A Raccordo a parete  $\varnothing 11$   
Wall drain-pipe fitting  $\varnothing 11$

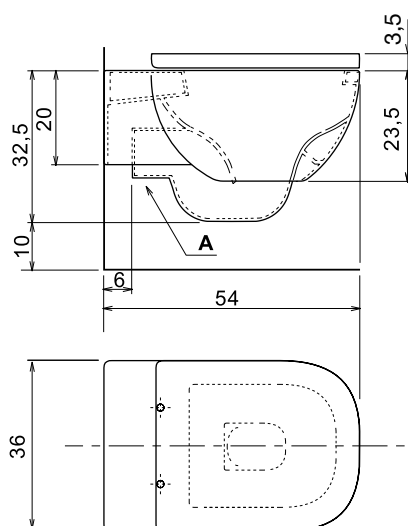

Vaso in ceramica sospeso con scarico a parete, completo di sedile avvolgente estraibile realizzato in resina termoindurente con cerniera frizionata sistema "soft-close".

Suspended wall mount ceramic water closet complete with removable toilet seat cover made of thermosetting resin with "soft-close" system hinge.



# SELLA



## art. SELLA2

Schemi scarichi bidet "SELLA2" con sifone "MICRO".  
 Technical drawing for drainage bidet "SELLA2" with trap "MICRO".

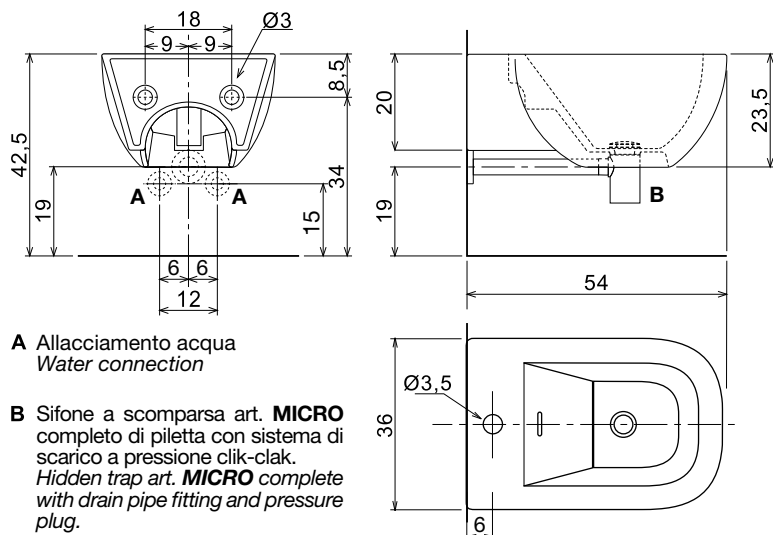

Schemi scarichi bidet "SELLA2".  
 Technical drawing for drainage bidet "SELLA2".

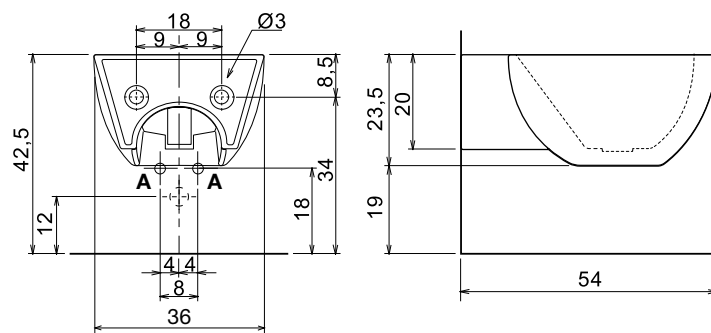

Bidet monoforo in ceramica sospeso con scarico a parete.  
 Suspended wall mount ceramic bidet with wall drainage and  
 single tap hole.

sanitari  
sanitary-ware





# SELLA



sanitari  
sanitary-ware







sanitari  
sanitary-ware

# ABOL



art. ABOL1

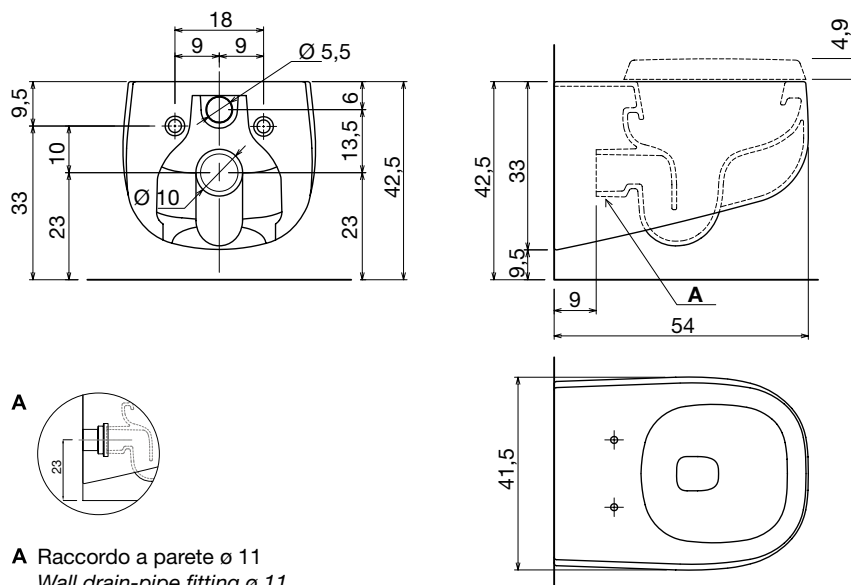

Vaso in ceramica sospeso con scarico a parete, completo di sedile avvolgente estraibile realizzato in resina termoindurente con cerniera frizionata sistema "soft-close".

*Suspended wall mount ceramic water closet complete with removable toilet seat cover made of thermosetting resin with "soft-close" system hinge.*



# ABOL



## art. ABOL2

Schema scarichi bidet "ABOL2" con sifone "MICRO".  
 Technical drawing for drainage bidet "ABOL2" with trap "MICRO".

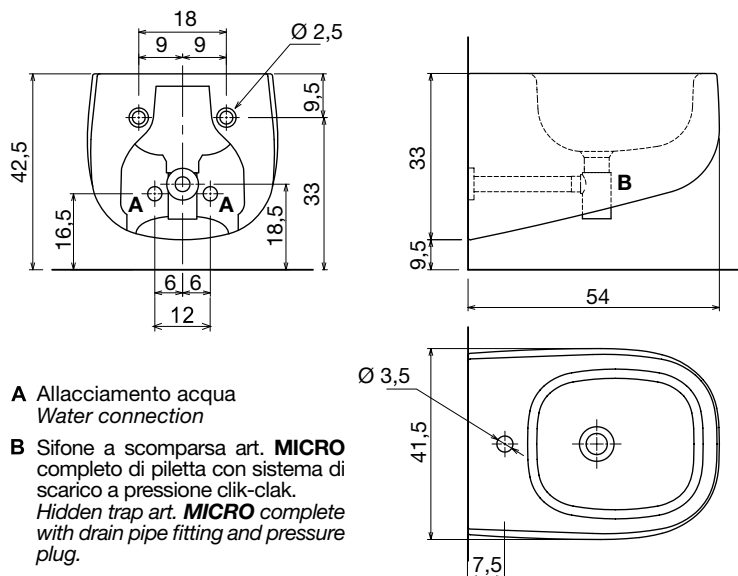

Schema scarichi bidet "ABOL2".  
 Technical drawing for drainage bidet "ABOL2".

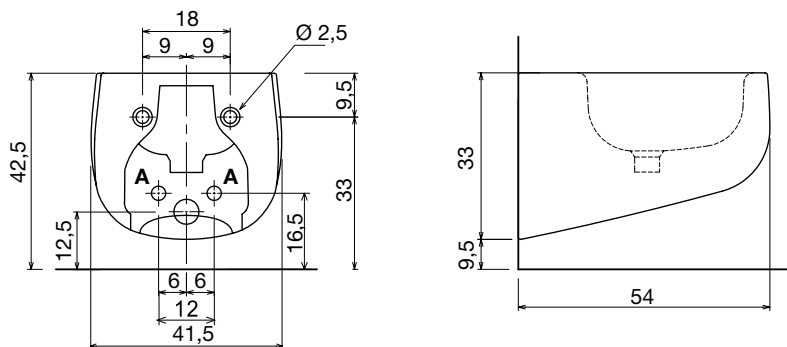

Bidet monoforo in ceramica sospeso con scarico a parete.

Suspended wall mount ceramic bidet with wall drainage and single tap hole.

sanitari  
sanitary-ware







# DUETTO



art. DUETTO21

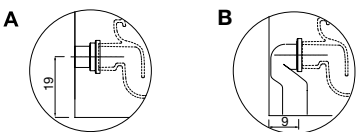
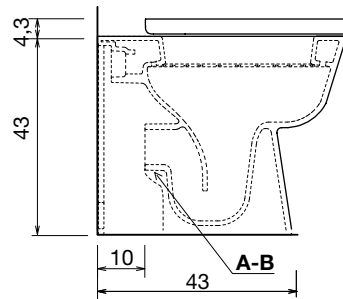
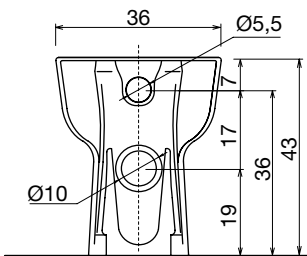

- A** Raccordo a parete ø 11  
Wall drain-pipe fitting ø 11
- B** Raccordo a pavimento ø 11  
Floor drain-pipe fitting ø 11

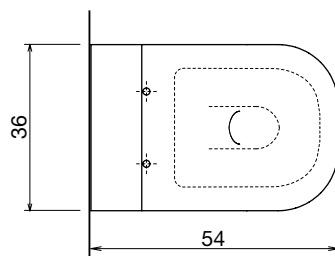

Vaso in ceramica da terra con scarico a pavimento o a parete, completo di sedile avvolgente estraibile realizzato in resina termoindurente con cerniera frizionata sistema "soft-close".

Freestanding ceramic water closet with floor or wall drain complete with toilet seat cover made of thermosetting resin and "soft-close" system hinge.



# DUETTO



art. DUETTO22

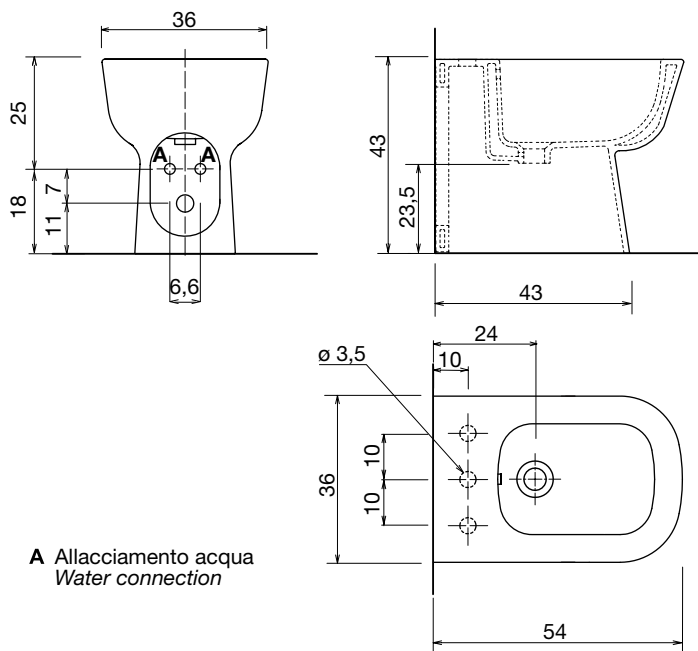

Bidet monoforo in ceramica da terra con scarico a parete.

Freestanding bidet with floor drainage and single center tap hole.

sanitari  
sanitary-ware







art. ONDA

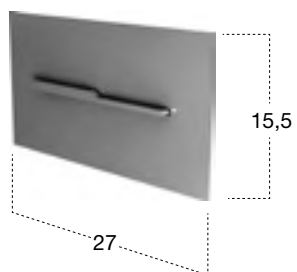

Placca di comando per cassetta wc a tasto unico basculante per il risciacquo a due quantità in acciaio inox AISI 304 satinato o lucido, completa di kit adattatore di montaggio.

*Mechanical dual flush plate for toilet cisterns in satin or polished stainless steel AISI 304 complete with installation adapter kit.*

## COLDSTONE

È un sistema di rivestimento del legno con ecomalte mono-componenti applicate con sette mani di spatolatura. Si tratta di un rivestimento protettivo che non contiene cemento, calce e resine epossidiche. Traspirante, non ingiallente, ha un'ottima flessibilità. Anche se non necessario poiché si tratta di prodotti non pericolosi, tutti i materiali del ciclo di rivestimento sono stati comunicati e codificati all'Istituto Superiore di Sanità.

- Conforme alla Direttiva 2004/42/CE relativa ai **(VOC)**.
- Conforme alla Direttiva CEE 89/106 **(IAQ)**: Qualità dell'aria all'interno degli ambienti.
- Non sviluppa gas tossici per l'ambiente e il sottosuolo.
- Ottima resistenza allo sporco.
- Ripristinabile.
- Non infiammabile.
- Non presenta catalogazioni di rischio, nocività, tossicità.
- Formulato nel rispetto della normativa relativa alla sicurezza del lavoro.

*It is a coating system for wood that involves the use of mono-component eco grouts applied with seven coatings. It is a protective coating that does not contain cement, lime and epoxy resin. It is transpiring and non-yellowing together with an excellent flexibility. All materials involved in the coating cycle have been communicated to and encoded by the Italian National Health Institute, despite the fact that these products are not classified as dangerous. Main characteristics of the product:*

- *Compliance with 2004/42/CE related to (VOC).*
- *Compliance with CEE89/106 (IAQ): indoor air quality.*
- *It does not produce toxic gases for the environment or the subsoil.*
- *Excellent resistance to dirt.*
- *Non-flammable.*
- *Not classified as risky, harmful, or toxic.*
- *Produced in compliance with work safety regulations.*



COLDSTONE



coldstone



## **7 mani di spatolatura 7 layers with a spatula**

Durata, resistenza e affidabilità, sono le caratteristiche del nostro Coldstone, caratterizzato da ben **sette mani di spatolatura** con ecomalte mono-componenti. Caratteristiche che lo distinguono e lo differenziano da prodotti che possono apparire simili.

*Durability, resistance and reliability are the hallmarks of our Coldstone, characterized by seven layers with a spatula of mono component ecomalt. Features that distinguish and differentiate it from products that may appear similar.*











coldstone





# COLDSTONE



- |    |                             |                                   |
|----|-----------------------------|-----------------------------------|
| P  | L                           |                                   |
| 40 | da 72 cm a 360 cm           | <b>art. CLS40 + art. QUADRO40</b> |
|    | <i>from 72 cm to 360 cm</i> |                                   |
| P  | L                           |                                   |
| 54 | da 72 cm a 360 cm           | <b>art. CLS54 + art. QUADRO54</b> |
|    | <i>from 72 cm to 360 cm</i> |                                   |

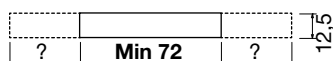
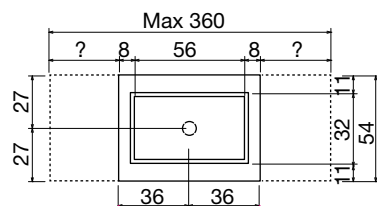
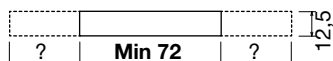
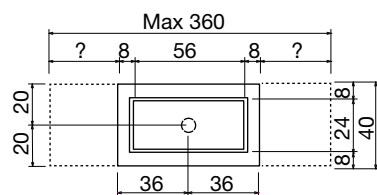

Top con lavabo integrato sopra piano o da parete in Coldstone, spess. 125 mm completo di piletta con scarico libero e raccordo per sifone.

*Top with integrated sink completely in Coldstone 125 mm thick complete with drain pipe fitting and open plug which may be wall mounted or used on furniture furniture.*

# FLUMOOD®

il perché della scelta di un nuovo materiale...

L'evoluzione tecnologica ci permette di poter usare nuovi materiali dalle caratteristiche straordinarie.

FLUMOOD è un materiale di nuova generazione, ecologico, compatto, non poroso, uniforme, atossico, con una superficie facilmente pulibile con i comuni prodotti per la pulizia domestica; inoltre può essere ripristinato semplicemente anche in caso di graffi o segni derivanti dall'uso quotidiano. Un materiale perfetto quindi per poter essere utilizzato nell'ambiente bagno.

antoniolupi, sicura della soddisfazione dei propri clienti, ha deciso di impiegarlo in alcuni suoi progetti di top e lavabi per i quali si è rivelato ideale sia nella finitura Satin che in quella Texture.

# FLUMOOD®

the reason for choosing a new material...

Technological evolution allows us to be able to use new material with extraordinary characteristics.

FLUMOOD is an innovative material, ecological, compact, non-porous, uniform, non-toxic with a surface easy to clean with common cleaning products; can be restored when scratched caused by everyday use. A perfect material for the bathroom.

antoniolupi is sure that customers will be completely satisfied and has decided to use this material in their projects concerning tops and sinks proved ideal in either the Satin or Textured finish.

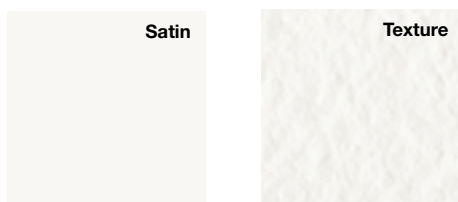



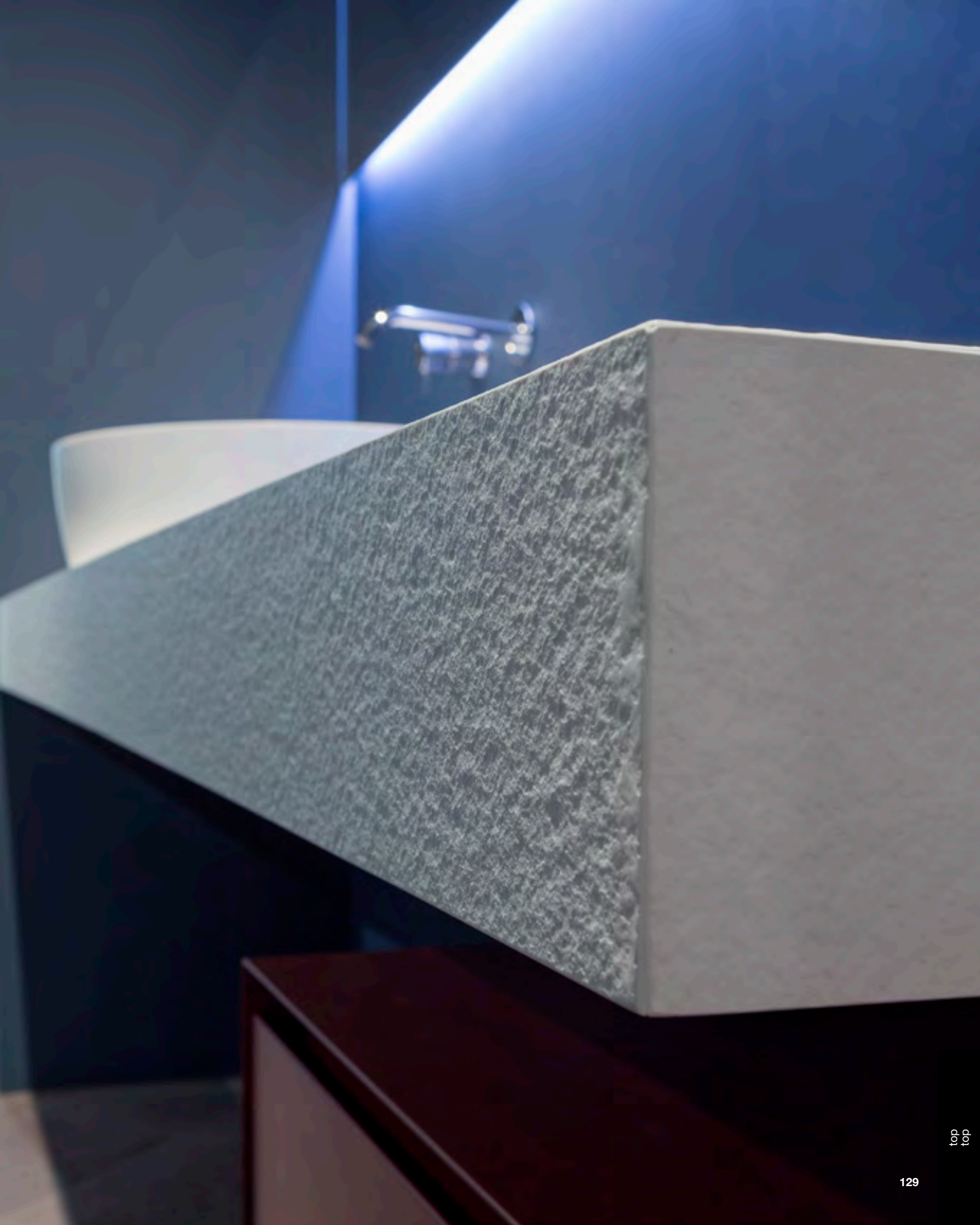







Satin

H  
40

L  
da 54 cm a 261 cm  
from 54 cm to 261 cm

art. BC140

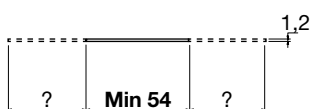
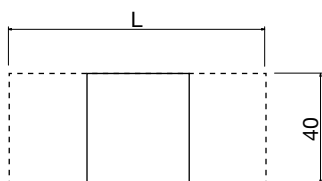

Alzatina in Flumood in finitura Satin.  
Flumood backsplash in Satin finish.

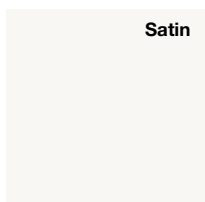

Per collezione / For collection **EXELEN - PIANA - LUNARIA - TEMPRA**

<b>A</b>		12 mm	P	
			40	art. BC140
			47	art. BC147
			54	art. BC154

Per collezione / For collection **PANTA REI**

<b>B</b>		12 mm	P	
			40	art. BC240
			47	art. BC247
			54	art. BC254

Per collezione / For collection **PLANETA**

<b>C</b>		12 mm	P	
			40	art. BC340
			47	art. BC347
			54	art. BC354

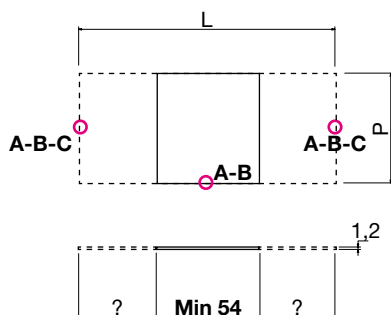

L  
da 54 cm a 263,4 cm  
from 54 cm to 263,4 cm

Top in Flumood in finitura Satin.

Flumood top in Satin finish.



# BASICO

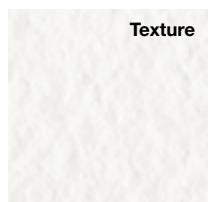

Per collezione / For collection **EXELEN - PIANA - LUNARIA - TEMPRA**

<b>A</b> 	12 mm	P	
		40	art. BC140
		47	art. BC147
		54	art. BC154

Per collezione / For collection **PANTA REI**

<b>B</b> 	12 mm	P	
		40	art. BC240
		47	art. BC247
		54	art. BC254

Per collezione / For collection **PLANETA**

<b>C</b> 	12 mm	P	
		40	art. BC340
		47	art. BC347
		54	art. BC354

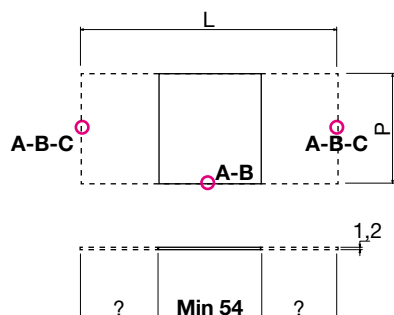

L  
da 54 cm a 263,4 cm  
from 54 cm to 263,4 cm

Top in Flumood in finitura Texture.

Flumood top in Texture finish.





# BASICO

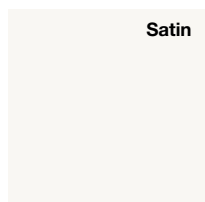

P	L	
40	da 72 cm a 261 cm <i>from 72 cm to 261 cm</i>	<b>art. BCS40</b>
47	da 72 cm a 261 cm <i>from 72 cm to 261 cm</i>	<b>art. BCS47</b>
54	da 72 cm a 261 cm <i>from 72 cm to 261 cm</i>	<b>art. BCS54</b>

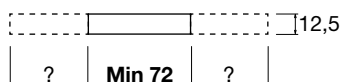
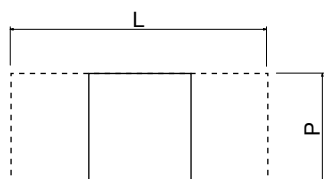

Top scatolare in Flumood in finitura Satin, completo di staffe in acciaio AISI 304 per fissaggio a parete.

*Suspended Flumood top in Satin finish, complete with steel AISI 304 supports for wall fixing.*





# BASICO

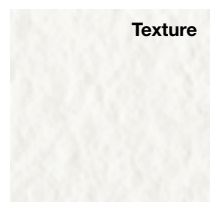

P	L	
40	da 72 cm a 261 cm <i>from 72 cm to 261 cm</i>	<b>art. BCS40</b>
47	da 72 cm a 261 cm <i>from 72 cm to 261 cm</i>	<b>art. BCS47</b>
54	da 72 cm a 261 cm <i>from 72 cm to 261 cm</i>	<b>art. BCS54</b>

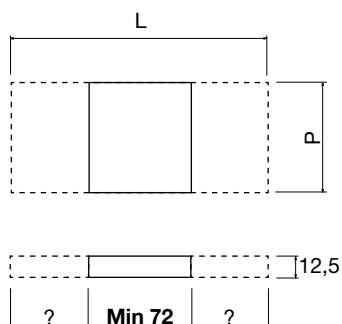

Top scatolare in Flumood in finitura Texture, completo di staffe in acciaio AISI 304 per fissaggio a parete.

*Suspended Flumood top in Texture finish, complete with steel AISI 304 supports for wall fixing.*





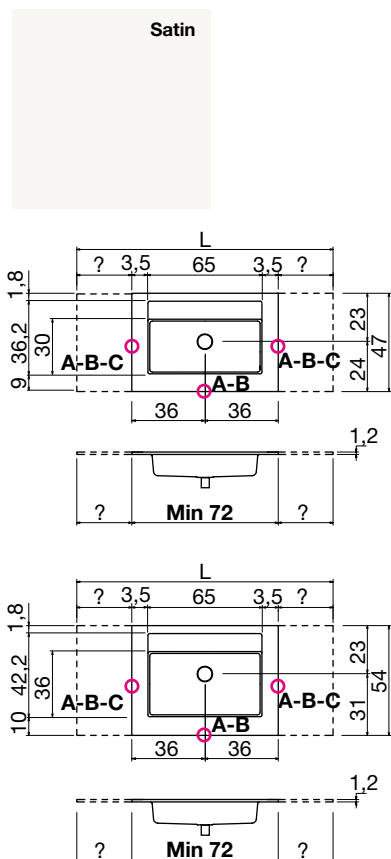

# BASICO



Per collezione / For collection **EXELEN - PIANA - LUNARIA - TEMPRA**

**A**  12 mm P  
47 art. **BASICO147**  
54 art. **BASICO154**

Per collezione / For collection **PANTA REI**

**B**  12 mm P  
47 art. **BASICO247**  
54 art. **BASICO254**

Per collezione / For collection **PLANETA**

**C**  12 mm P  
47 art. **BASICO347**  
54 art. **BASICO354**

L  
da 72 cm a 263,4 cm  
from 72 cm to 263,4 cm

Top con lavabo integrato sopra piano in Flumood in finitura Satin, spessore 12 mm completo di piletta con scarico libero e raccordo per sifone.  
**N.B.** solo per porta lavabi H 37,5 e H 50 cm. Nei porta lavabi H 37,5 è possibile inserire solo sifone art. MICRO.

Top with integrated sink in Flumood Satin finish, 12 mm thick, complete with drain pipe fitting and open plug.  
**P.S.** only for sink units cm 37,5 and 50 H. In sink units cm 37,5 H it is only possible to use siphon art. MICRO.





# BASICO

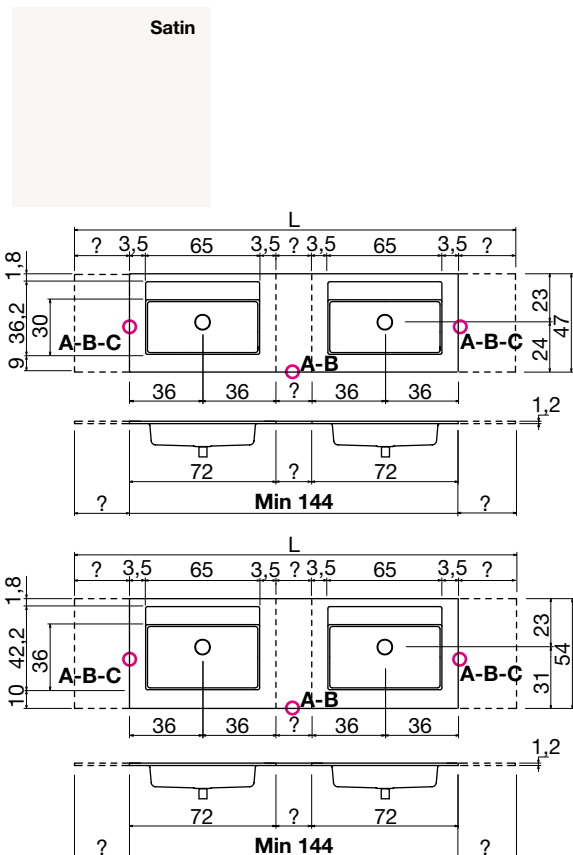

Per collezione / For collection **EXELEN - PIANA - LUNARIA - TEMPRA**

<b>A</b>		12 mm	P	47	<b>art. BASICO1147</b>
				54	<b>art. BASICO1154</b>

Per collezione / For collection **PANTA REI**

<b>B</b>		12 mm	P	47	<b>art. BASICO2147</b>
				54	<b>art. BASICO2154</b>

Per collezione / For collection **PLANETA**

<b>C</b>		12 mm	P	47	<b>art. BASICO3147</b>
				54	<b>art. BASICO3154</b>

**L**  
da 144 cm a 263,4 cm  
from 144 cm to 263,4 cm

Top con doppio lavabo integrato sopraiano in Flumood in finitura Satin, spessore 12 mm, completo di piletta con scarico libero e raccordo per sifone.

**N.B.** solo per porta lavabi H 37,5 e H 50 cm. Nei porta lavabi H 37,5 è possibile inserire solo sifone art. MICRO.

Top with double integrated sink in Flumood Satin finish, 12 mm thick, with drain pipe fitting and open plug.  
**P.S.** only for sink units cm 37,5 and 50 H. In sink units cm 37,5 H it is only possible to use siphon art. MICRO.





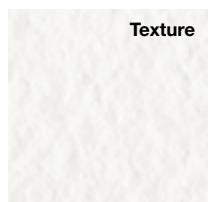



Texture

Per collezione / For collection **EXELEN - PIANA - LUNARIA - TEMPRA**

**A**  12 mm P 54 art. **PODIO1108**

Per collezione / For collection **PANTA REI**

**B**  12 mm P 54 art. **PODIO2108**

Per collezione / For collection **PLANETA**

**C**  12 mm P 54 art. **PODIO3108**

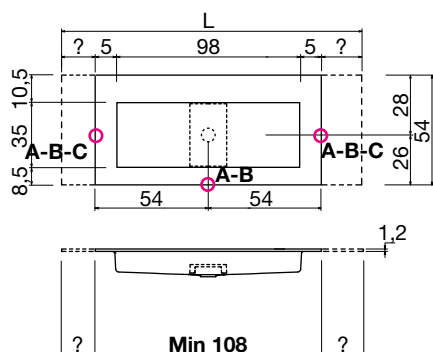

L  
da 108 cm a 263,4 cm  
from 108 cm to 263,4 cm

Top con lavabo integrato sopraiano in Flumood in finitura Texture, spessore 12 mm completo di piletta con scarico libero e raccordo per sifone.

**N.B.** solo per porta lavabi H 37,5 e H 50 cm. Nei porta lavabi H 37,5 è possibile inserire solo sifone art. MICRO.

Top with integrated sink in Flumood Texture finish, 12 mm thick, complete with drain pipe fitting and open plug.

**P.S.** only for sink units cm 37,5 and 50 H. In sink units cm 37,5 H it is only possible to use siphon art. MICRO.











# PODIO

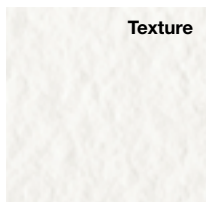

Texture

P 54 L da 108 cm a 261 cm  
from 108 cm to 261 cm

art. **PODIOXL**

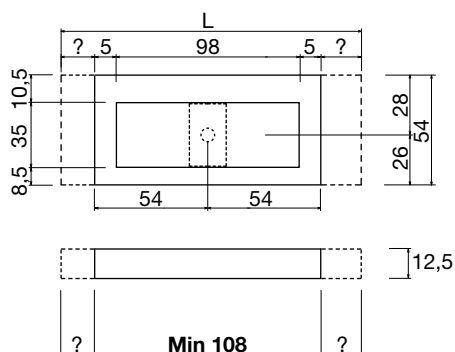

Top con lavabo integrato sopra piano o da parete in Flumood in finitura Texture, spessore 125 mm, completo di pileta con scarico libero e raccordo per sifone.

Top with integrated sink in Flumood Texture finish, 125 mm thick complete with drain pipe fitting and open plug which may be wall mounted or used on furniture.

# BASICO

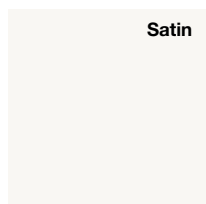

P	L	
47	da 72 cm a 261 cm <i>from 72 cm to 261 cm</i>	<b>art. BASICOXL47</b>
54	da 72 cm a 261 cm <i>from 72 cm to 261 cm</i>	<b>art. BASICOXL</b>

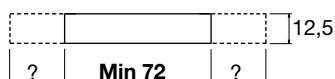
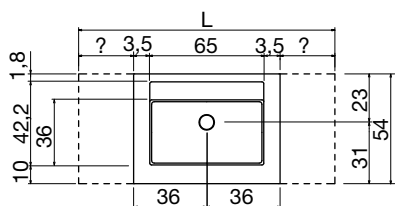
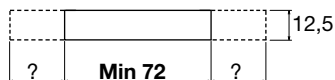
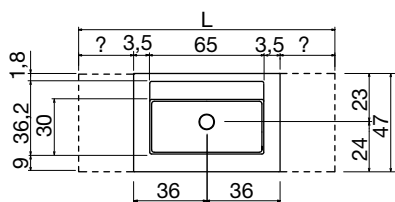

Top con lavabo integrato sopra piano o da parete in Flumood in finitura Satin, spessore 125 mm, completo di pileta con scarico libero e raccordo per sifone.

Top with integrated sink in Flumood Satin finish, 125 mm thick complete with drain pipe fitting and open plug which may be wall mounted or used on furniture.



# BASICO

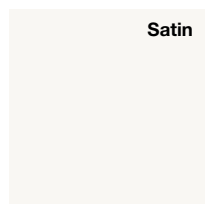
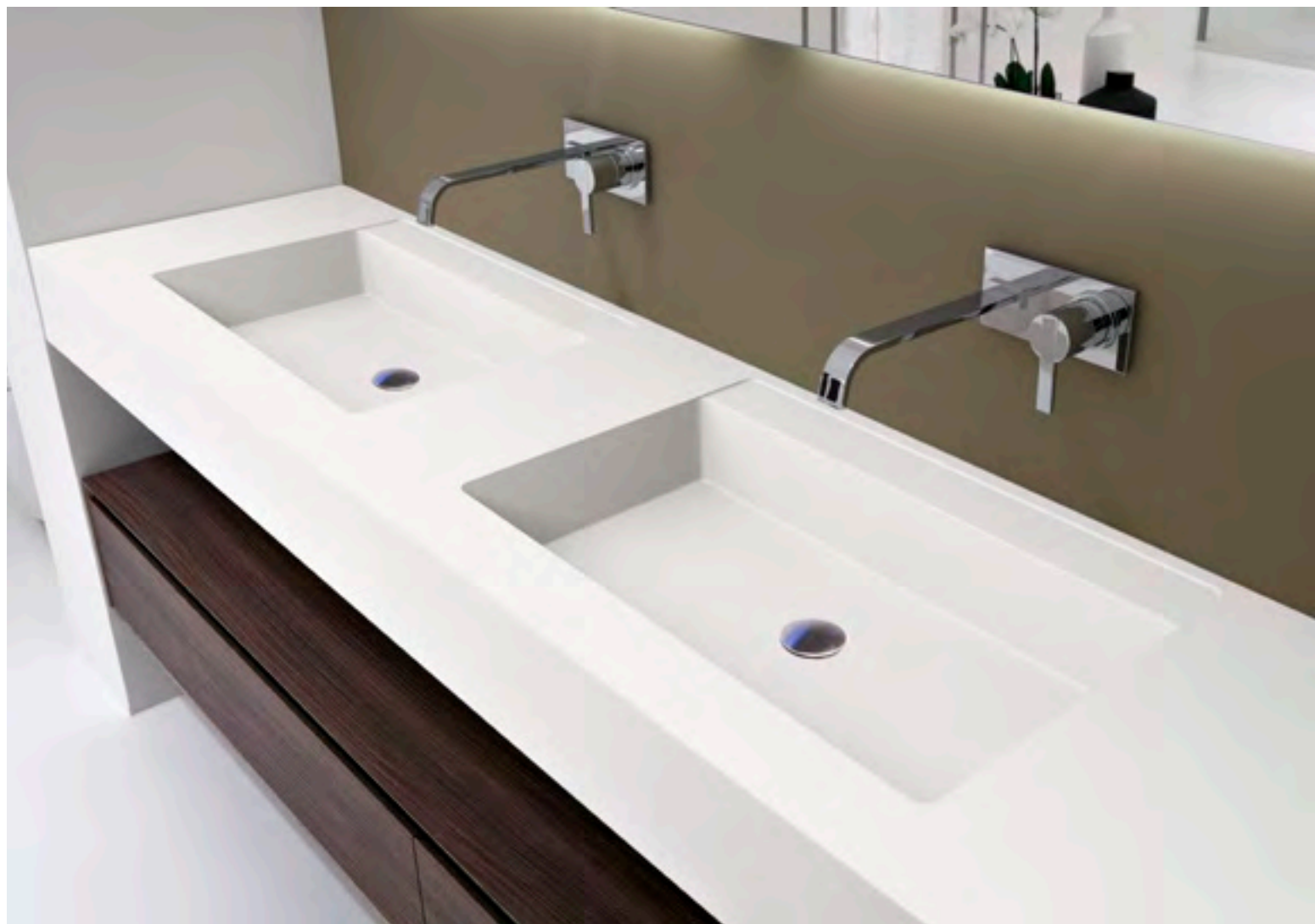

P  
47  
54

L  
da 144 cm a 261 cm  
*from 144 cm to 261 cm*  
da 144 cm a 261 cm  
*from 144 cm to 261 cm*

art. **BASICOAD47**

art. **BASICOAD**

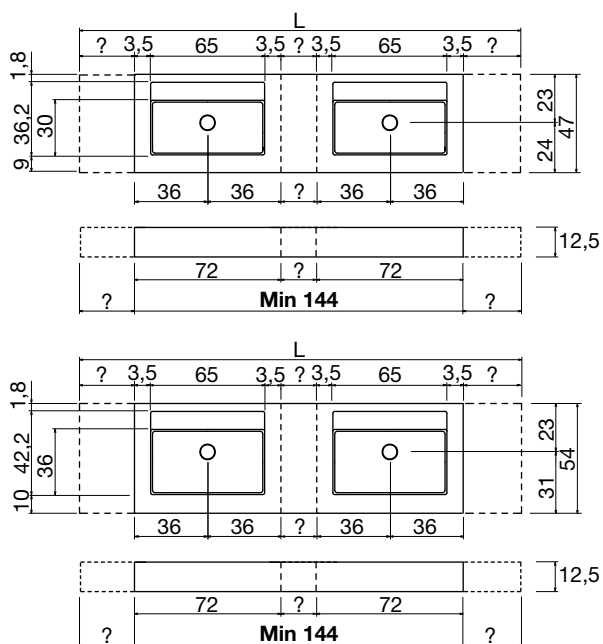

Top con doppio lavabo integrato sopraiano o da parete in Flumood in finitura Satin, spessore 125 mm, completo di piletta con scarico libero e raccordo per sifone.

Top with double integrated sink in Flumood Satin finish, 125 mm thick complete with drain pipe fitting and open plug which may be wall mounted or used on furniture.













Per collezione / For collection **PIANA - EXELEN**

**A**  14 mm **P** 40 **L** da 74,4 cm a 272,4 cm  
from 74,4 cm to 272,4 cm **art. TOPLUX40**

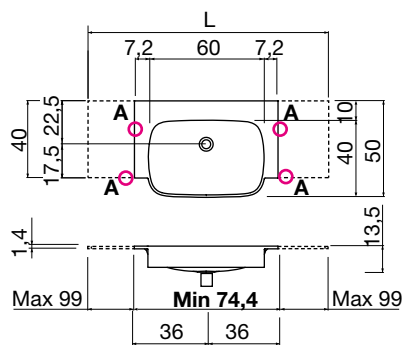

Top con lavabo integrato sopraiano in Ceramilux spessore 14 mm in finitura lucida, completo di piletta con scarico libero e raccordo per sifone.

Top with integrated sink in Ceramilux 14 mm thick in glossy finish, complete with open plug and drain pipe fitting.







Per collezione / For collection **PIANA - EXELEN**

14 mm    P    L  
 40    da 74,4 cm a 272,4 cm  
 from 74,4 cm to 272,4 cm

**art. TOPMATT40**

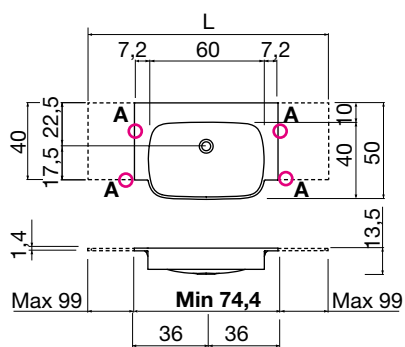

Top con lavabo integrato soprapiano in Ceramilux spessore 14 mm in finitura opaca, completo di piletta con scarico libero e raccordo per sifone.

Top with integrated sink in Ceramilux 14 mm thick in matt finish, complete with open plug and drain pipe fitting.

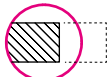

Per collezione / For collection **LUNARIA**

A		P	L	art. <b>CP140</b> + art. <b>COPPA</b>
		14 mm	40	

Per collezione / For collection **PANTA REI**

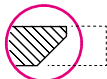
B		P	L	art. <b>CP240</b> + art. <b>COPPA</b>
		14 mm	40	

Per collezione / For collection **PLANETA**

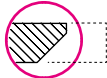
C		P	L	art. <b>CP340</b> + art. <b>COPPA</b>
		14 mm	40	

Per collezione / For collection **PIANA - EXELEN**

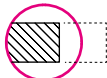
A		P	L	art. <b>CP140</b> + art. <b>COPPA</b>
		14 mm	40	

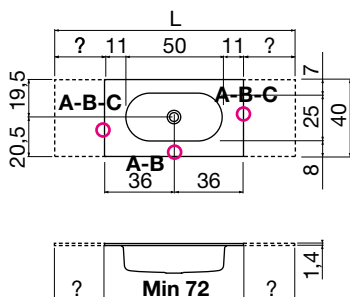

Top con lavabo integrato sopraiano in Cristalplant biobased spessore 14 mm, completo di piletta con scarico libero e raccordo per sifone.

**N.B.** solo per porta lavabi H 37,5 e H 50 cm. Nei porta lavabi H 37,5 è possibile inserire solo sifone art. MICRO.

Solo per rubinetteria a parete e monoforo dx o sx.

Top with integrated sink in biobased Cristalplant 14 mm thick, complete with drain pipe fitting and open plug.

**P.S.** only for sink units cm 37,5 H and 50 H. In sink units cm 37, 5 H it is only possible to use siphon art. MICRO

Only for wall mount taps or single tap hole on right or left side.



# COPPA



- |  |        |         |  |                                 |
|--|--------|---------|--|---------------------------------|
|  | 60 mm  | P<br>40 | L<br>da 72 cm a 297 cm<br>from 72 cm to 297 cm | <b>art. CPS640 + art. COPPA</b> |
|  | 125 mm | 40      | da 72 cm a 297 cm<br>from 72 cm to 297 cm      | <b>art. CPS40 + art. COPPA</b>  |

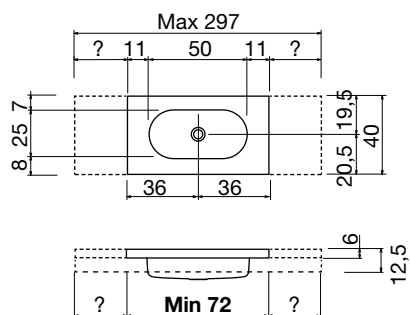

Top con lavabo integrato da parete in Cristalplant biobased spessore 60-125 mm, completo di piletta con scarico libero e raccordo per sifone.

**N.B.** Solo per rubinetteria a parete e monoforo dx o sx.

*Suspended Top with integrated sink in biobased Cristalplant 60-125 mm thick, complete with drain pipe fitting and open plug.*

**P.S.** Only for wall mount taps or single tap hole on right or left side.





## A CIASCUNO IL SUO

CONCA ARENA GEMMA PIEGA design Nevio Tellatin

**A CIASCUNO IL SUO** è una collezione straordinariamente dinamica di top e lavabi in Cristalplant, caratterizzata da una grande possibilità di personalizzazioni di forme e dimensioni.

L'impiego di un innovativo sistema di stampi dinamici, consente infatti di realizzare praticamente ogni pezzo su misura.

Non sono solo le dimensioni ad essere variabili: combinando tipologia e posizione dei lavabi, nonché accostamenti, spessori ed alzatine, si possono ottenere infinite combinazioni che conferiranno unicità e ricercatezza al vostro ambiente bagno.

A CIASCUNO IL SUO è un sistema che antoniolupi mette a disposizione dei progettisti perché, in piena libertà e sicurezza, possano realizzare quanto desiderano.

Ogni particolare è infatti studiato e armonizzato con i sistemi antoniolupi e le sue collezioni **PANTA REI, PLANETA, PIANA, EXELEN, LUNARIA**.

Eleganza, purezza formale, qualità dei materiali e delle finiture, i tratti che da sempre caratterizzano antoniolupi, si fondono con praticità di utilizzo e facilità di manutenzione.

Razionalità e estro creativo, convivono in questo progetto, perché quando il buon design che è fatto di forma e sostanza e la cultura aziendale che è fatta di ricerca, di desiderio di soddisfare le esigenze di progettisti e clienti, di proposta, si incontrano, non possono che generare qualità e bellezza.

## TO EACH HIS OWN...

CONCA ARENA GEMMA PIEGA design Nevio Tellatin

**TO EACH HIS OWN...** is an extraordinarily dynamic collection of tops and sinks in Cristalplant characterized by a great possibility of customization in shapes and sizes.

The use of an innovative system of dynamic molds makes it possible to achieve virtually any custom top. Not only variable in sizes: by combining type and position of the sinks, as well as combinations, thicknesses and backsplashes, you can achieve endless results that will give uniqueness and sophistication to your bathroom.

**TO EACH HIS OWN...** is a system that antoniolupi provides designers because, in complete freedom and safety, they can achieve what they desire.

Every detail is in fact designed and harmonized with the antoniolupi system and collections **PANTA REI, PLANETA, PIANA, EXELEN, LUNARIA**. Elegance, purity of form, quality of materials and finishes, the features that have always characterized antoniolupi are combined with ease of use and ease of maintenance.

Rationality and inspiration, coexist in this project because good design made from form and substance, and corporate culture, made from research and desire fulfill the needs of designers, clients and proposals generating quality and beauty.

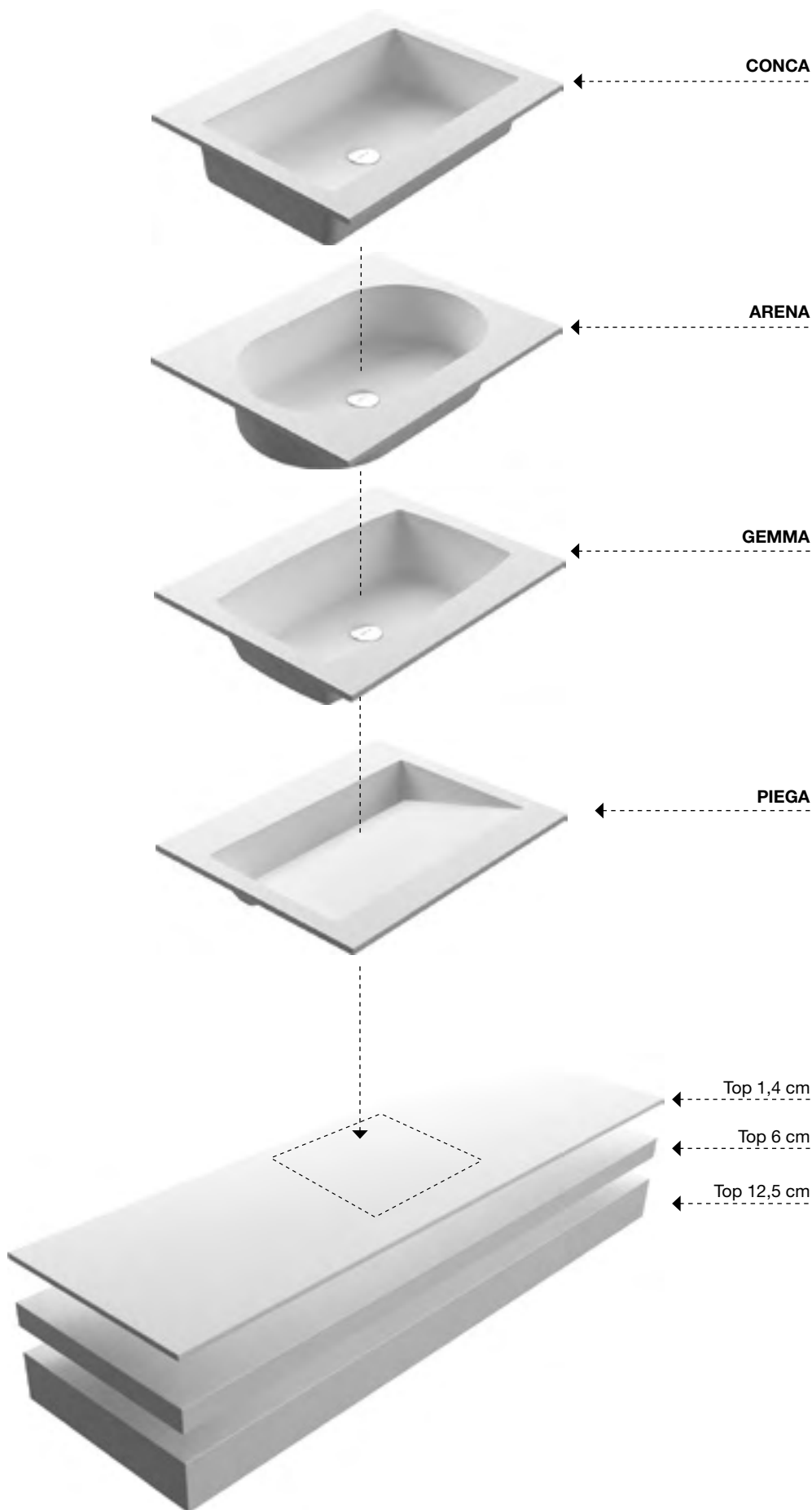









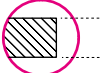

Per collezione / For collection **LUNARIA**

**A**  14 mm P 54 L da 72 cm a 216 cm  
from 72 cm to 216 cm **art. CP154 + art. CONCA**

Per collezione / For collection **PANTA REI**

**B**  14 mm P 54 L da 72 cm a 216 cm  
from 72 cm to 216 cm **art. CP254 + art. CONCA**

Per collezione / For collection **PLANETA**

**C**  14 mm P 54 L da 72 cm a 216 cm  
from 72 cm to 216 cm **art. CP354 + art. CONCA**

Per collezione / For collection **PIANA - EXELEN**

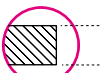
**A**  14 mm P 54 L da 74,4 cm a 299,4 cm  
from 74,4 cm to 299,4 cm **art. CP154 + art. CONCA**

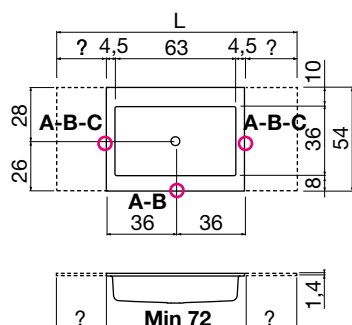

Top con lavabo integrato soprapiano in Cristalplant biobased spessore 14 mm, completo di piletta con scarico libero e raccordo per sifone.

**N.B.** solo per porta lavabi H 37,5 e H 50 cm. Nei porta lavabi H 37,5 è possibile inserire solo sifone art. MICRO.



Top with integrated sink in biobased Cristalplant 14 mm thick complete with drain pipe fitting and open plug.

**P.S.** only for sink units cm 37,5 H and 50 H. In sink units cm 37, 5 H it is only possible to use siphon art. MICRO.



# CONCA



	60 mm	P 54	L da 72 cm a 297 cm from 72 cm to 297 cm	<b>art. CPS654 + art. CONCA</b>
	125 mm	54	da 72 cm a 297 cm from 72 cm to 297 cm	<b>art. CPS54 + art. CONCA</b>

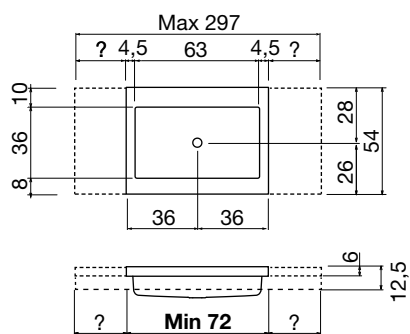

Top con lavabo integrato da parete in Cristalplant biobased spessore 60-125 mm, completo di piletta con scarico libero e raccordo per sifone.

*Suspended Top with integrated sink in biobased Cristalplant 60-125 mm thick, complete with drain pipe fitting and open plug.*

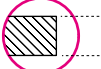

Per collezione / For collection **LUNARIA**

**A**  14 mm P L  
54 da 144 cm a 216 cm art. CP154 + n° 2 art. CONCA  
from 144 cm to 216 cm

Per collezione / For collection **PANTA REI**

**B**  14 mm P L  
54 da 144 cm a 216 cm art. CP254 + n° 2 art. CONCA  
from 144 cm to 216 cm

Per collezione / For collection **PLANETA**

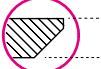
**C**  14 mm P L  
54 da 144 cm a 216 cm art. CP354 + n° 2 art. CONCA  
from 144 cm to 216 cm

Per collezione / For collection **PIANA - EXELEN**

**A**  14 mm P L  
54 da 146,4 cm a 299,4 cm art. CP154 + n° 2 art. CONCA  
from 146,4 cm to 299,4 cm

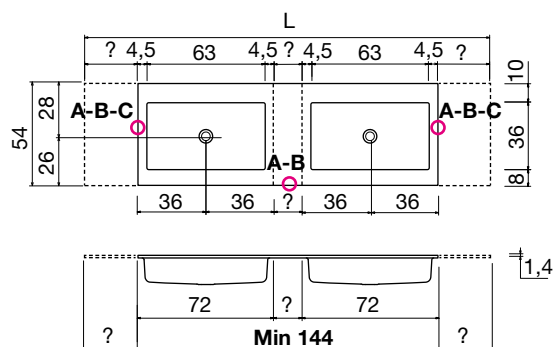

Top con doppio lavabo integrato sopraiano in Cristalplant biobased spessore 14 mm, completo di piletta con scarico libero e raccordo per sifone.

**N.B.** solo per porta lavabi H 37,5 e H 50 cm. Nei porta lavabi H 37,5 è possibile inserire solo sifone art. MICRO.

Top with double integrated sink in biobased Cristalplant 14 mm thick complete with drain pipe fitting and open plug.

**P.S.** only for sink units cm 37,5 H and 50 H. In sink units cm 37,5 H it is only possible to use siphon art. MICRO.



# CONCA



60 mm

P  
54

L

da 144 cm a 297 cm  
from 144 cm to 297 cm

art. CPS654 + n° 2 art. CONCA



125 mm

54

da 144 cm a 297 cm  
from 144 cm to 297 cm

art. CPS54 + n° 2 art. CONCA

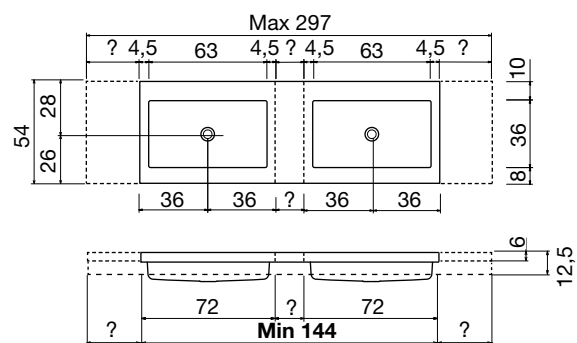

Top con doppio lavabo integrato da parete in Cristalplant biobased spessore 60-125 mm, completo di piletta con scarico libero e raccordo per sifone.

Suspended Top with double integrated sink in biobased Cristalplant 60-125 mm thick, complete with drain pipe fitting and open plug.







# ARENA



Per collezione / For collection **LUNARIA**

**A**  14 mm P 54 L da 72 cm a 216 cm  
from 72 cm to 216 cm **art. CP154 + art. ARENA**

Per collezione / For collection **PANTA REI**

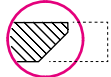
**B**  14 mm P 54 L da 72 cm a 216 cm  
from 72 cm to 216 cm **art. CP254 + art. ARENA**

Per collezione / For collection **PLANETA**

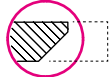
**C**  14 mm P 54 L da 72 cm a 216 cm  
from 72 cm to 216 cm **art. CP354 + art. ARENA**

Per collezione / For collection **PIANA - EXELEN**

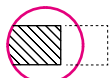
**A**  14 mm P 54 L da 74,4 cm a 299,4 cm  
from 74,4 cm to 299,4 cm **art. CP154 + art. ARENA**

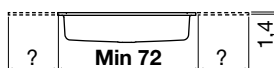
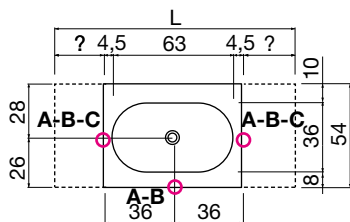

Top con lavabo integrato sopraiano in Cristalplant biobased spessore 14 mm, completo di piletta con scarico libero e raccordo per sifone.

**N.B.** solo per porta lavabi H 37,5 e H 50 cm. Nei porta lavabi H 37,5 è possibile inserire solo sifone art. MICRO.

Top with integrated sink in biobased Cristalplant 14 mm thick complete with drain pipe fitting and open plug.

**P.S.** only for sink units cm 37,5 H and 50 H. In sink units cm 37,5 H it is only possible to use siphon art. MICRO



# ARENA

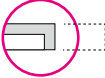
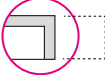

	60 mm	P 54	L da 72 cm a 297 cm <i>from 72 cm to 297 cm</i>	<b>art. CPS654 + art. ARENA</b>
	125 mm	54	da 72 cm a 297 cm <i>from 72 cm to 297 cm</i>	<b>art. CPS54 + art. ARENA</b>

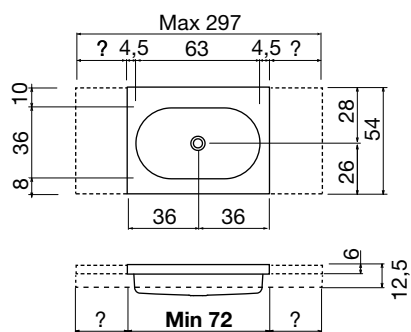

Top con lavabo integrato da parete in Cristalplant biobased spessore 60-125 mm, completo di piletta con scarico libero e raccordo per sifone.

*Suspended Top with integrated sink in biobased Cristalplant 60-125 mm thick, complete with drain pipe fitting and open plug.*

# ARENA



Per collezione / For collection **LUNARIA**

**A**  14 mm 54 P L  
da 144 cm a 216 cm  
from 144 cm to 216 cm

art. CP154 + n° 2 art. ARENA

Per collezione / For collection **PANTA REI**

**B**  14 mm 54 P L  
da 144 cm a 216 cm  
from 144 cm to 216 cm

art. CP254 + n° 2 art. ARENA

Per collezione / For collection **PLANETA**

**C**  14 mm 54 P L  
da 144 cm a 216 cm  
from 144 cm to 216 cm

art. CP354 + n° 2 art. ARENA

Per collezione / For collection **PIANA - EXELEN**

**A**  14 mm 54 P L  
da 146,4 cm a 299,4 cm  
from 146,4 cm to 299,4 cm

art. CP154 + n° 2 art. ARENA

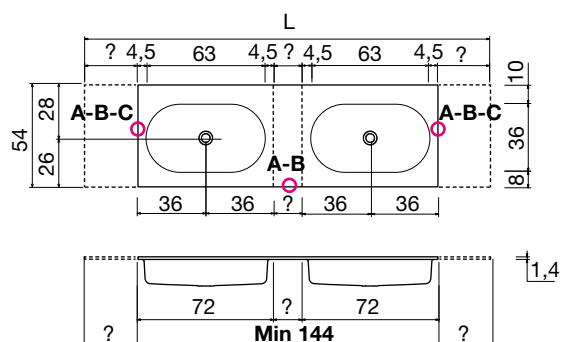

Top con doppio lavabo integrato sopraiano in Cristalplant biobased spessore 14 mm, completo di piletta con scarico libero e raccordo per sifone.

**N.B.** solo per porta lavabi H 37,5 e H 50 cm. Nei porta lavabi H 37,5 è possibile inserire solo sifone art. MICRO.

Top with double integrated sink in biobased Cristalplant 14 mm thick complete with drain pipe fitting and open plug.

**P.S.** only for sink units cm 37,5 H and 50 H. In sink units cm 37,5 H it is only possible to use siphon art. MICRO



# ARENA



60 mm

P  
54

L

da 144 cm a 297 cm  
from 144 cm to 297 cm

art. CPS654 + n° 2 art. ARENA



125 mm

P  
54

L

da 144 cm a 297 cm  
from 144 cm to 297 cm

art. CPS54 + n° 2 art. ARENA

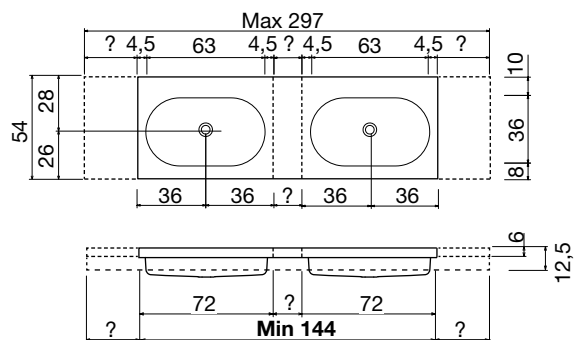

Top con doppio lavabo integrato da parete in Cristalplant biobased spessore 60-125 mm, completo di piletta con scarico libero e raccordo per sifone.

Suspended Top with double integrated sink in biobased Cristalplant 60-125 mm thick, complete with drain pipe fitting and open plug.







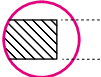

Per collezione / For collection **LUNARIA**

<b>A</b>		P	L	<b>art. CP154 + art. GEMMA</b>
		14 mm 54	da 72 cm a 216 cm from 72 cm to 216 cm	

Per collezione / For collection **PANTA REI**

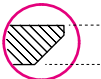
<b>B</b>		P	L	<b>art. CP254 + art. GEMMA</b>
		14 mm 54	da 72 cm a 216 cm from 72 cm to 216 cm	

Per collezione / For collection **PLANETA**

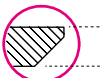
<b>C</b>		P	L	<b>art. CP354 + art. GEMMA</b>
		14 mm 54	da 72 cm a 216 cm from 72 cm to 216 cm	

Per collezione / For collection **PIANA - EXELEN**

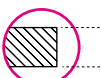
<b>A</b>		P	L	<b>art. CP154 + art. GEMMA</b>
		14 mm 54	da 74,4 cm a 299,4 cm from 74,4 cm to 299,4 cm	

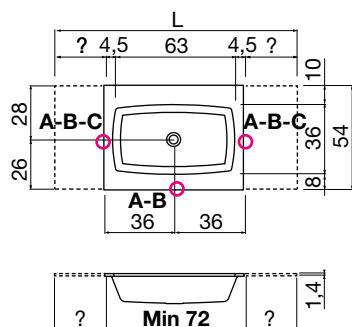

Top con lavabo integrato soprapiano in Cristalplant biobased spessore 14 mm, completo di piletta con scarico libero e raccordo per sifone.

**N.B.** solo per porta lavabi H 37,5 e H 50 cm. Nei porta lavabi H 37,5 è possibile inserire solo sifone art. MICRO.

Top with integrated sink in biobased Cristalplant 14 mm thick complete with drain pipe fitting and open plug.

**P.S.** only for sink units cm 37,5 H and 50 H. In sink units cm 37,5 H it is only possible to use siphon art. MICRO.



# GEMMA



- |  |        |         |  |                                 |
|--|--------|---------|--|---------------------------------|
|  | 60 mm  | P<br>54 | L<br>da 72 cm a 297 cm<br>from 72 cm to 297 cm | <b>art. CPS654 + art. GEMMA</b> |
|  | 125 mm | 54      | da 72 cm a 297 cm<br>from 72 cm to 297 cm      | <b>art. CPS54 + art. GEMMA</b>  |

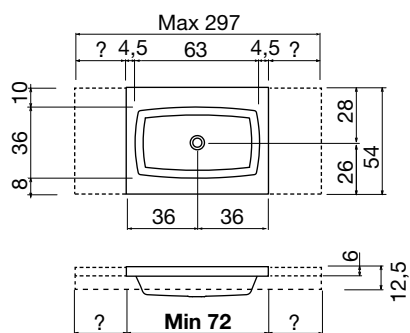

Top con lavabo integrato da parete in Cristalplant biobased spessore 60-125 mm, completo di piletta con scarico libero e raccordo per sifone.

*Suspended Top with integrated sink in biobased Cristalplant 60-125 mm thick, complete with drain pipe fitting and open plug.*

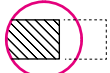

Per collezione / For collection **LUNARIA**

**A**  14 mm P 54 L da 144 cm a 216 cm  
from 144 cm to 216 cm **art. CP154 + n° 2 art. GEMMA**

Per collezione / For collection **PANTA REI**

**B**  14 mm P 54 L da 144 cm a 216 cm  
from 144 cm to 216 cm **art. CP254 + n° 2 art. GEMMA**

Per collezione / For collection **PLANETA**

**C**  14 mm P 54 L da 144 cm a 216 cm  
from 144 cm to 216 cm **art. CP354 + n° 2 art. GEMMA**

Per collezione / For collection **PIANA - EXELEN**

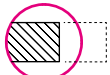
**A**  14 mm P 54 L da 146,4 cm a 299,4 cm  
from 146,4 cm to 299,4 cm **art. CP154 + n° 2 art. GEMMA**

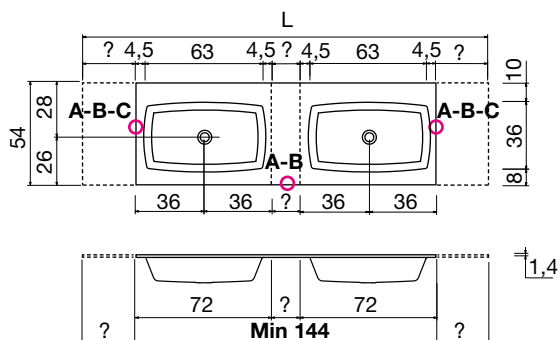

Top con doppio lavabo integrato soprapiano in Cristalplant biobased spessore 14 mm, completo di piletta con scarico libero e raccordo per sifone.

**N.B.** solo per porta lavabi H 37,5 e H 50 cm. Nei porta lavabi H 37,5 è possibile inserire solo sifone art. MICRO.

Top with double integrated sink in biobased Cristalplant 14 mm thick complete with drain pipe fitting and open plug.

**P.S.** only for sink units cm 37,5 H and 50 H. In sink units cm 37, 5 H it is only possible to use siphon art. MICRO



# GEMMA



60 mm

P  
54

L

da 144 cm a 297 cm  
from 144 cm to 297 cm

art. CPS654 + n° 2 art. GEMMA



125 mm

P  
54

L

da 144 cm a 297 cm  
from 144 cm to 297 cm

art. CPS54 + n° 2 art. GEMMA

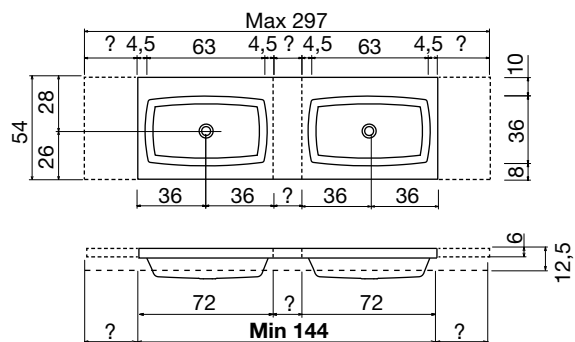

Top con doppio lavabo integrato da parete in Cristalplant biobased spessore 60-125 mm, completo di piletta con scarico libero e raccordo per sifone.

Suspended Top with double integrated sink in biobased Cristalplant 60-125 mm thick, complete with drain pipe fitting and open plug.







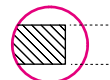

Per collezione / For collection **LUNARIA**

**A**  14 mm P 54 L da 72 cm a 216 cm **art. CP154 + art. PIEGA**  
from 72 cm to 216 cm

Per collezione / For collection **PANTA REI**

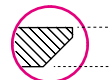
**B**  14 mm P 54 L da 72 cm a 216 cm **art. CP254 + art. PIEGA**  
from 72 cm to 216 cm

Per collezione / For collection **PLANETA**

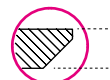
**C**  14 mm P 54 L da 72 cm a 216 cm **art. CP354 + art. PIEGA**  
from 72 cm to 216 cm

Per collezione / For collection **PIANA - EXELEN**

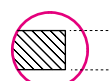
**A**  14 mm P 54 L da 74,4 cm a 299,4 cm **art. CP154 + art. PIEGA**  
from 74,4 cm to 299,4 cm

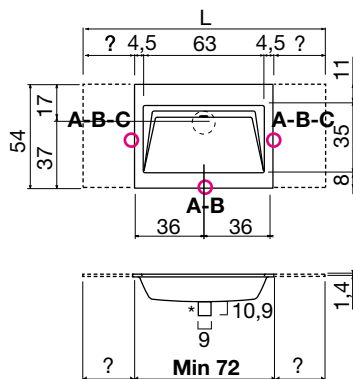

Top con lavabo integrato soprapiano in Cristalplant biobased spessore 14 mm, con sistema di scarico predisposto per sifone.

**N.B.** solo per porta lavabi H 37,5 e H 50 cm. Nei porta lavabi H 37,5 è possibile inserire solo sifone art. MICRO.

\* Carter sifone

Top with integrated sink in biobased Cristalplant 14 mm thick, with drain prepared for siphon.



**P.S.** only for sink units cm 37,5 H and 50 H. In sink units cm 37, 5 H it is only possible to use siphon art. MICRO.

\* Siphon cover



# PIEGA



	60 mm	P 54	L da 72 cm a 297 cm <i>from 72 cm to 297 cm</i>	<b>art. CPS654 + art. PIEGA</b>
	125 mm	P 54	L da 72 cm a 297 cm <i>from 72 cm to 297 cm</i>	<b>art. CPS54 + art. PIEGA</b>

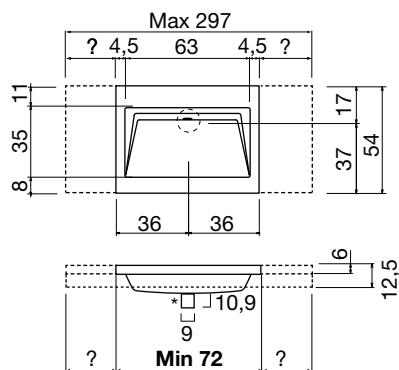

Top con lavabo integrato da parete in Cristalplant biobased spessore 60-125 mm, con sistema di scarico predisposto per sifone.

\* Carter sifone

*Suspended Top with integrated sink in biobased Cristalplant 60-125 mm thick, with drain prepared for siphon.*

\* Siphon cover

# PIEGA

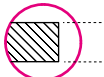

Per collezione / For collection **LUNARIA**

**A**  14 mm P L  
54 da 144 cm a 216 cm  
from 144 cm to 216 cm **art. CP154 + n° 2 art. PIEGA**

Per collezione / For collection **PANTA REI**

**B**  14 mm P L  
54 da 144 cm a 216 cm  
from 144 cm to 216 cm **art. CP254 + n° 2 art. PIEGA**

Per collezione / For collection **PLANETA**

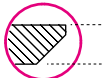
**C**  14 mm P L  
54 da 144 cm a 216 cm  
from 144 cm to 216 cm **art. CP354 + n° 2 art. PIEGA**

Per collezione / For collection **PIANA - EXELEN**

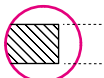
**A**  14 mm P L  
54 da 146,4 cm a 299,4 cm  
from 146,4 cm to 299,4 cm **art. CP154 + n° 2 art. PIEGA**

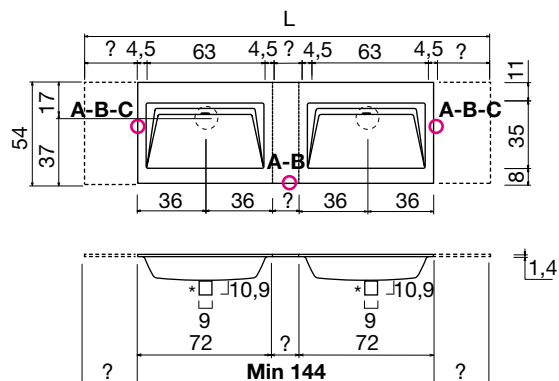

Top con doppio lavabo integrato soprapiano in Cristalplant biobased spessore 14 mm, con sistema di scarico predisposto per sifone.

**N.B.** solo per porta lavabi H 37,5 e H 50 cm. Nei porta lavabi H 37,5 è possibile inserire solo sifone art. MICRO.

\* Carter sifone

Top with double integrated sink in biobased Cristalplant 14 mm thick, with drain prepared for siphon.

**P.S.** only for sink units cm 37,5 H and 50 H. In sink units cm 37,5 H it is only possible to use siphon art. MICRO.

\* Siphon cover



# PIEGA



P 60 mm 54

L da 144 cm a 297 cm  
from 144 cm to 297 cm

art. CPS654 + n° 2 art. PIEGA



P 125 mm 54

L da 144 cm a 297 cm  
from 144 cm to 297 cm

art. CPS54 + n° 2 art. PIEGA

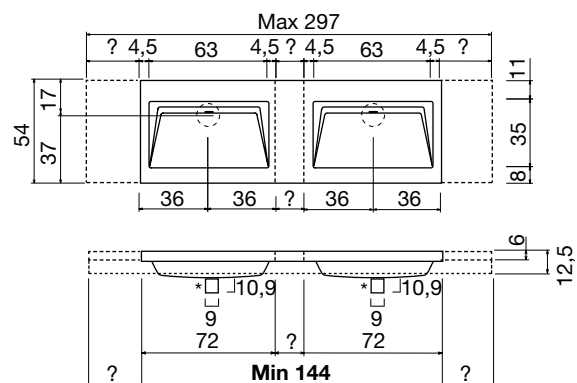

Top con doppio lavabo integrato da parete in Cristalplant biobased spessore 60-125 mm, con sistema di scarico predisposto per sifone.

\* Carter sifone

Suspended top with double integrated sink in biobased Cristalplant 60-125 mm thick, with drain prepared for siphon.

\* Siphon cover





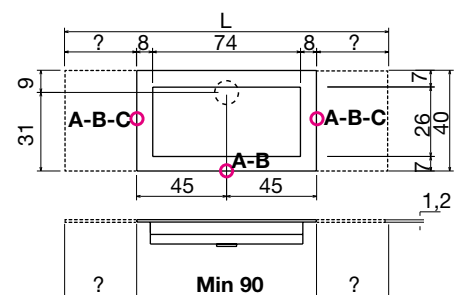
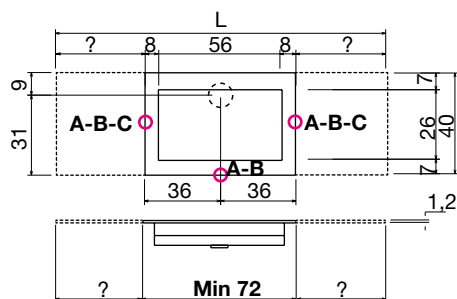



Per collezione / For collection **LUNARIA**

<b>A</b> 	P	L	
	12 mm	40	da 72 cm a 216 cm from 72 cm to 216 cm
	40		da 90 cm a 216 cm from 90 cm to 216 cm
			<b>art. CR140 + art. MYSLOT472</b>
			<b>art. CR140 + art. MYSLOT490</b>

Per collezione / For collection **PANTA REI**

<b>B</b> 	P	L	
	12 mm	40	da 72 cm a 216 cm from 72 cm to 216 cm
	40		da 90 cm a 216 cm from 90 cm to 216 cm
			<b>art. CR240 + art. MYSLOT472</b>
			<b>art. CR240 + art. MYSLOT490</b>

Per collezione / For collection **PLANETA**

<b>C</b> 	P	L	
	12 mm	40	da 72 cm a 216 cm from 72 cm to 216 cm
	40		da 90 cm a 216 cm from 90 cm to 216 cm
			<b>art. CR340 + art. MYSLOT472</b>
			<b>art. CR340 + art. MYSLOT490</b>

Per collezione / For collection **PIANA - EXELEN**

<b>A</b> 	P	L	
	12 mm	40	da 74,4 cm a 299,4 cm from 74,4 cm to 299,4 cm
	40		da 92,4 cm a 299,4 cm from 92,4 cm to 299,4 cm
			<b>art. CR140 + art. MYSLOT472</b>
			<b>art. CR140 + art. MYSLOT490</b>

Top con lavabo integrato sopraiano in Corian spessore 12 mm, con sistema di scarico predisposto per sifone.

**N.B.** solo per porta lavabi H 37,5 e H 50 cm. Nei porta lavabi H 37,5 è possibile inserire solo sifone art. MICRO. Solo per rubinetteria a parete.

Top with integrated sink completely in Corian 12 mm thick, with drain prepared for siphon.  
**P.S.** only for sink units cm 37,5 and 50 H. In sink units cm 37,5 H it is only possible to use siphon art. MICRO. Only for wall mount tap.

# MYSLOT

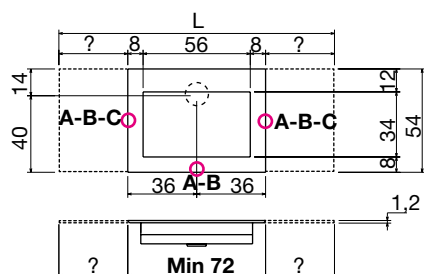

Per collezione / For collection **LUNARIA**

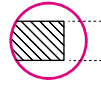
<b>A</b> 	12 mm	P	L	
		54	54	da 72 cm a 216 cm from 72 cm to 216 cm
				<b>art. CR154 + art. MYSLOT72</b>
				<b>art. CR154 + art. MYSLOT90</b>

Per collezione / For collection **PANTA REI**

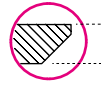
<b>B</b> 	12 mm	P	L	
		54	54	da 72 cm a 216 cm from 72 cm to 216 cm
				<b>art. CR254 + art. MYSLOT72</b>
				<b>art. CR254 + art. MYSLOT90</b>

Per collezione / For collection **PLANETA**

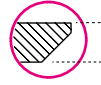
<b>C</b> 	12 mm	P	L	
		54	54	da 72 cm a 216 cm from 72 cm to 216 cm
				<b>art. CR354 + art. MYSLOT72</b>
				<b>art. CR354 + art. MYSLOT90</b>

Per collezione / For collection **PIANA - EXELEN**

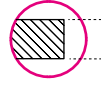
<b>A</b> 	12 mm	P	L	
		54	54	da 74,4 cm a 299,4 cm from 74,4 cm to 299,4 cm
				<b>art. CR154 + art. MYSLOT72</b>
				<b>art. CR154 + art. MYSLOT90</b>

Top con lavabo integrato soprapiano in Corian spessore 12 mm, con sistema di scarico predisposto per sifone.

**N.B.** solo per porta lavabi H 37,5 e H 50 cm. Nei porta lavabi H 37,5 è possibile inserire solo sifone art. MICRO.

Top with integrated sink completely in Corian 12 mm thick, with drain prepared for siphon.  
**P.S.** only for sink units cm 37,5 and 50 H. In sink units cm 37,5 H it is only possible to use siphon art. MICRO.



# MYSLOT

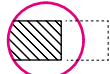

Per collezione / For collection **LUNARIA**

**A**  12 mm 54 P L da 144 cm a 216 cm  
from 144 cm to 216 cm **art. CR154 + n° 2 art. MYSLOT72**

Per collezione / For collection **PANTA REI**

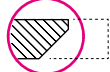
**B**  12 mm 54 P L da 144 cm a 216 cm  
from 144 cm to 216 cm **art. CR254 + n° 2 art. MYSLOT72**

Per collezione / For collection **PLANETA**

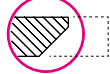
**C**  12 mm 54 P L da 144 cm a 216 cm  
from 144 cm to 216 cm **art. CR354 + n° 2 art. MYSLOT72**

Per collezione / For collection **PIANA - EXELEN**

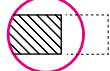
**A**  12 mm 54 P L da 146,4 cm a 299,4 cm  
from 146,4 cm to 299,4 cm **art. CR154 + n° 2 art. MYSLOT72**

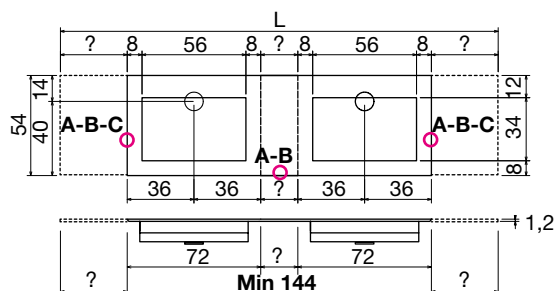

Top con doppio lavabo integrato soprapiano in Corian spessore 12 mm, con sistema di scarico predisposto per sifone.

**N.B.** solo per porta lavabi H 37,5 e H 50 cm. Nei porta lavabi H 37,5 è possibile inserire solo sifone art. MICRO.

Top with double integrated sink completely in Corian 12 mm thick, with drain prepared for siphon.

**P.S.** only for sink units cm 37,5 and 50 H. In sink units cm 37,5 H it is only possible to use siphon art. MICRO.





# MYSLOT

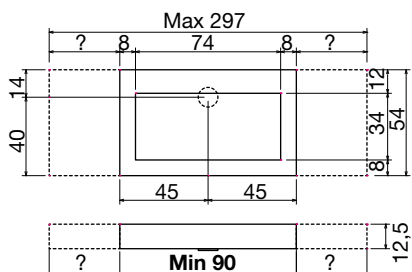
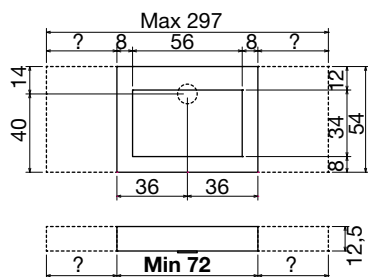

P	L	
54	da 72 cm a 297 cm from 72 cm to 297 cm	art. CRS54 + art. MYSLOT72
54	da 90 cm a 297 cm from 90 cm to 297 cm	art. CRS54 + art. MYSLOT90

Top con lavabo integrato sopraiano o da parete in Corian, spess. 125 mm con sistema di scarico predisposto per sifone.

Top with integrated sink completely in Corian 125 mm thick with drain prepared for siphon that can be wall mounted or used on furniture.





# MYSLOT



P 54 L da 144 cm a 297 cm art. CRS54 + n° 2 art. MYSLOT72  
 from 144 cm to 297 cm

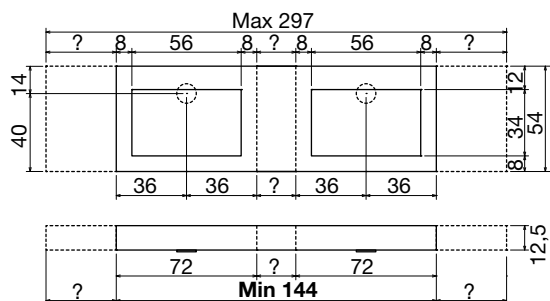

Top con doppio lavabo integrato soprapiano o da parete in Corian, spess. 125 mm con sistema di scarico predisposto per sifone.

Top with double integrated sinks completely in Corian 125 mm thick with drain prepared for siphon that can be wall mounted or used on furniture.

top  
top







P  
54

L  
da 72 cm a 297 cm  
from 72 cm to 297 cm

art. **SLOTXL**

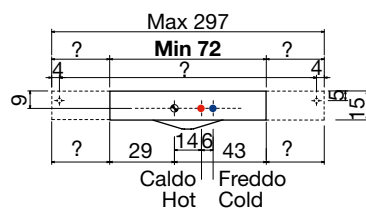
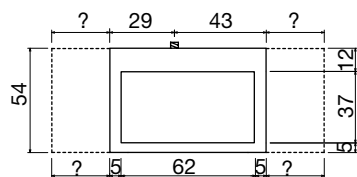

Top con lavabo integrato soprapiano o da parete in Corian spess. 150 mm, con sifone incorporato.

Top with integrated sink in Corian 150 mm thick with incorporated trap which may be wall mounted or used on furniture.





# SLOT



P  
54

L  
da 144 cm a 297 cm  
from 144 cm to 297 cm

art. SLODAD

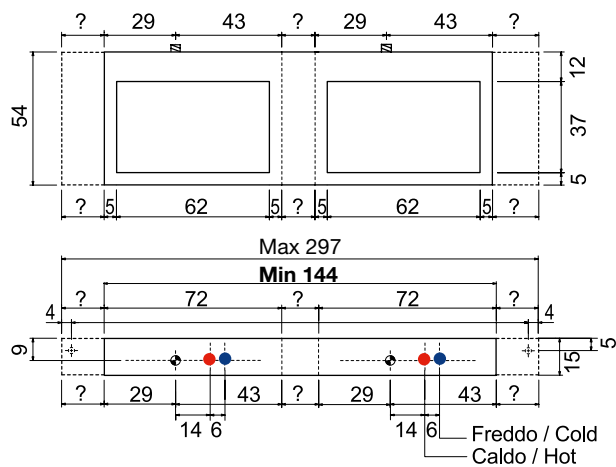

Top con doppio lavabo integrato soprapiano o da parete in Corian spess. 150 mm, con sifone incorporato.

Top with double integrated sink completely in Corian 150 mm thick and incorporated trap which may be wall mounted or used on furniture.



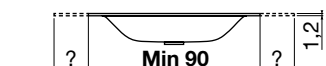
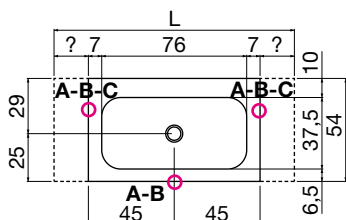
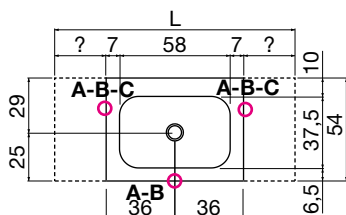



Per collezione / For collection **LUNARIA**

<b>A</b> 	12 mm	P 54	L da 72 cm a 216 cm from 72 cm to 216 cm	<b>art. CR154 + art. SEGNO72</b>
		54	da 90 cm a 216 cm from 90 cm to 216 cm	<b>art. CR154 + art. SEGNO90</b>

Per collezione / For collection **PANTA REI**

<b>B</b> 	12 mm	P 54	L da 72 cm a 216 cm from 72 cm to 216 cm	<b>art. CR254 + art. SEGNO72</b>
		54	da 90 cm a 216 cm from 90 cm to 216 cm	<b>art. CR254 + art. SEGNO90</b>

Per collezione / For collection **PLANETA**

<b>C</b> 	12 mm	P 54	L da 72 cm a 216 cm from 72 cm to 216 cm	<b>art. CR354 + art. SEGNO72</b>
		54	da 90 cm a 216 cm from 90 cm to 216 cm	<b>art. CR354 + art. SEGNO90</b>

Per collezione / For collection **PIANA - EXELEN**

<b>A</b> 	12 mm	P 54	L da 74,4 cm a 299,4 cm from 74,4 cm to 299,4 cm	<b>art. CR154 + art. SEGNO72</b>
		54	da 92,4 cm a 299,4 cm from 92,4 cm to 299,4 cm	<b>art. CR154 + art. SEGNO90</b>

Top con lavabo integrato soprapiano in Corian spessore 12 mm, completo di piletta con scarico libero e raccordo per sifone.

**N.B.** solo per porta lavabi H 37,5 e H 50 cm. Nei porta lavabi H 37,5 è possibile inserire solo sifone art. MICRO.

Top with integrated sink completely in Corian 12 mm thick, with drain pipe fitting and open plug.

**P.S.** only for sink units cm 37,5 and 50 H. In sink units cm 37,5 H it is only possible to use siphon art. MICRO.



# SEGNO



Per collezione / For collection **LUNARIA**

**A**  12 mm P 54 L da 144 cm a 216 cm  
from 144 cm to 216 cm **art. CR154 + n° 2 art. SEGNO72**

Per collezione / For collection **PANTA REI**

**B**  12 mm P 54 L da 144 cm a 216 cm  
from 144 cm to 216 cm **art. CR254 + n° 2 art. SEGNO72**

Per collezione / For collection **PLANETA**

**C**  12 mm P 54 L da 144 cm a 216 cm  
from 144 cm to 216 cm **art. CR354 + n° 2 art. SEGNO72**

Per collezione / For collection **PIANA - EXELEN**

**A**  12 mm P 54 L da 146,4 cm a 299,4 cm  
from 146,4 cm to 299,4 cm **art. CR154 + n° 2 art. SEGNO72**

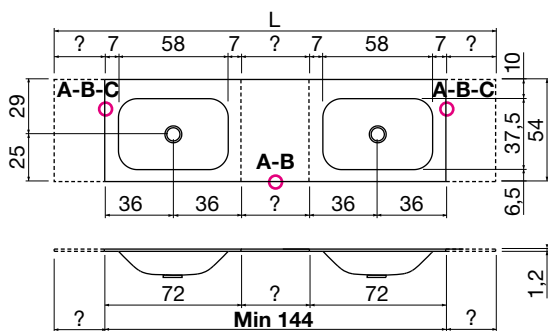

Top con doppio lavabo integrato soprapiano in Corian spessore 12 mm, completo di piletta con scarico libero e raccordo per sifone.

**N.B.** solo per porta lavabi H 37,5 e H 50 cm. Nei porta lavabi H 37,5 è possibile inserire solo sifone art. MICRO.

*Top with double integrated sink completely in Corian 12 mm thick, with drain pipe fitting and open plug.*

**P.S.** only for sink units cm 37,5 and 50 H. In sink units cm 37,5 H it is only possible to use siphon art. MICRO.

# SEGNO



Per collezione / For collection **LUNARIA**

**A**  12 mm P 54 L da 180 cm a 216 cm  
from 180 cm to 216 cm art. CR154 + n° 2 art. SEGNO90

Per collezione / For collection **PANTA REI**

**B**  12 mm P 54 L da 180 cm a 216 cm  
from 180 cm to 216 cm art. CR254 + n° 2 art. SEGNO90

Per collezione / For collection **PLANETA**

**C**  12 mm P 54 L da 180 cm a 216 cm  
from 180 cm to 216 cm art. CR354 + n° 2 art. SEGNO90

Per collezione / For collection **PIANA - EXELEN**

**A**  12 mm P 54 L da 182,4 cm a 299,4 cm  
from 182,4 cm to 299,4 cm art. CR154 + n° 2 art. SEGNO90

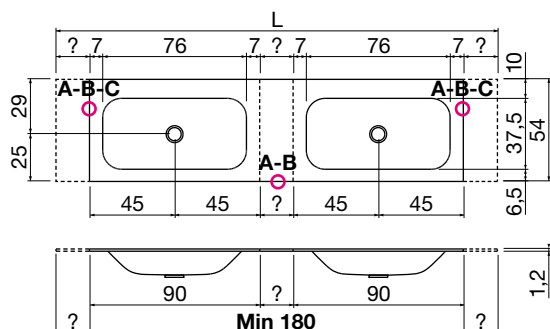

Top con doppio lavabo integrato soprapiano in Corian spessore 12 mm, completo di piletta con scarico libero e raccordo per sifone.

**N.B.** solo per porta lavabi H 37,5 e H 50 cm. Nei porta lavabi H 37,5 è possibile inserire solo sifone art. MICRO.

Top with double integrated sink completely in Corian 12 mm thick, with drain pipe fitting and open plug.

**P.S.** only for sink units cm 37,5 and 50 H. In sink units cm 37,5 H it is only possible to use siphon art. MICRO.

# SEGNO



P	L	
54	da 72 cm a 297 cm <i>from 72 cm to 297 cm</i>	<b>art. CRS54 + art. SEGNO72</b>
54	da 90 cm a 297 cm <i>from 90 cm to 297 cm</i>	<b>art. CRS54 + art. SEGNO90</b>

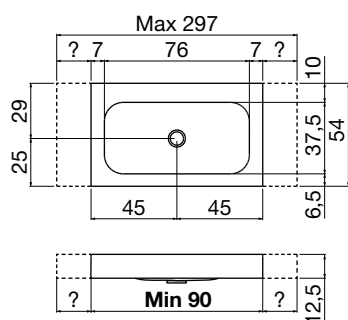
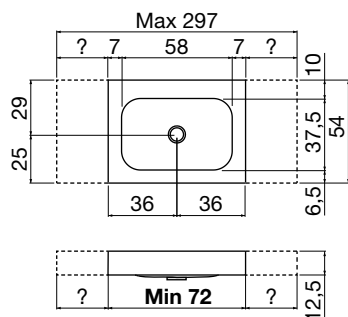

Top con lavabo integrato sopraiano o da parete in Corian spessore 125 mm, completo di pileta con scarico libero e raccordo per sifone.

*Top with integrated sink completely in Corian 125 mm thick complete with drain pipe fitting and open plug which may be wall mounted or used on furniture.*



# SEGNO



P 54 L da 144 cm a 297 cm art. CRS54 + n° 2 art. SEGNO72  
 from 144 cm to 297 cm

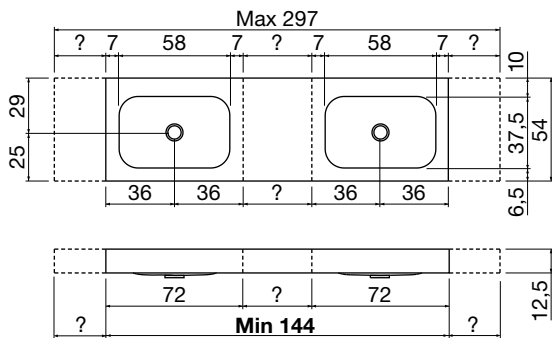

Top con doppio lavabo integrato soprapiano o da parete in Corian spessore 125 mm, completo di piletta con scarico libero e raccordo per sifone.

Top with double integrated sink completely in Corian 125 mm thick complete with drain pipe fitting and open plug which may be wall mounted or used on furniture.

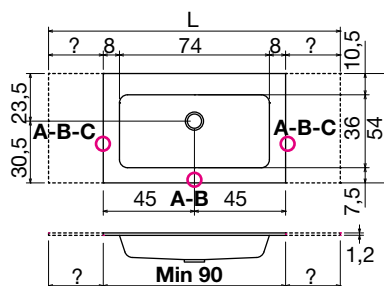
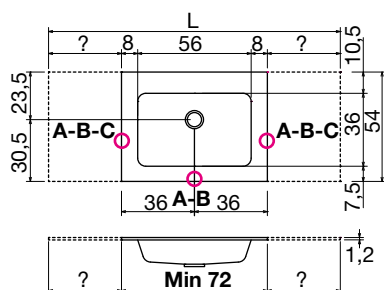

Per collezione / For collection **LUNARIA**

<b>A</b> 	12 mm	P	L	
	54	54	da 72 cm a 216 cm from 72 cm to 216 cm	<b>art. CR154 + art. ARCO72</b>
	54		da 90 cm a 216 cm from 90 cm to 216 cm	<b>art. CR154 + art. ARCO90</b>

Per collezione / For collection **PANTA REI**

<b>B</b> 	12 mm	P	L	
	54	54	da 72 cm a 216 cm from 72 cm to 216 cm	<b>art. CR254 + art. ARCO72</b>
			da 90 cm a 216 cm from 90 cm to 216 cm	<b>art. CR254 + art. ARCO90</b>

Per collezione / For collection **PLANETA**

<b>C</b> 	12 mm	P	L	
	54	54	da 72 cm a 216 cm from 72 cm to 216 cm	<b>art. CR354 + art. ARCO72</b>
			da 90 cm a 216 cm from 90 cm to 216 cm	<b>art. CR354 + art. ARCO90</b>

Per collezione / For collection **PIANA - EXELEN**

<b>A</b> 	12 mm	P	L	
	54	54	da 74,4 cm a 299,4 cm from 74,4 cm to 299,4 cm	<b>art. CR154 + art. ARCO72</b>
			da 92,4 cm a 299,4 cm from 92,4 cm to 299,4 cm	<b>art. CR154 + art. ARCO90</b>

Top con lavabo integrato soprapiano in Corian, spess. 12 mm completo di piletta con scarico libero e raccordo per sifone.

**N.B.** solo per porta lavabi H 37,5 e H 50 cm. Nei porta lavabi H 37,5 è possibile inserire solo sifone art. MICRO.

Top with integrated sink completely in Corian 12 mm thick, complete with drain pipe fitting and open plug.

**P.S.** only for sink units cm 37,5 H and 50 H. In sink units cm 37,5 H it is only possible to use siphon art. MICRO.

# ARCO



- |    |                             |                          |
|----|-----------------------------|--------------------------|
| P  | L                           |                          |
| 54 | da 72 cm a 297 cm           | art. CRS54 + art. ARCO72 |
|    | <i>from 72 cm to 297 cm</i> |                          |
| 54 | da 90 cm a 297 cm           | art. CRS54 + art. ARCO90 |
|    | <i>from 90 cm to 297 cm</i> |                          |

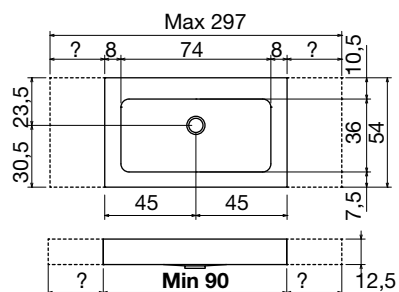
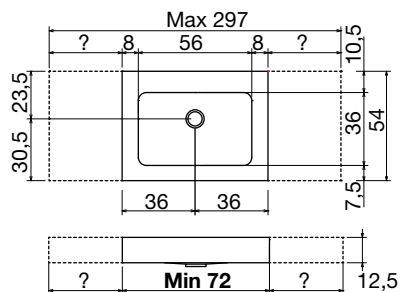

Top con lavabo integrato soprapiano o da parete in Corian, spess. 125 mm completo di pileta con scarico libero e raccordo per sifone.

*Top with integrated sink completely in Corian 125 mm thick, complete with drain pipe fitting and open plug which may be wall mounted or used on furniture.*



# ARCO



P L  
 54 da 144 cm a 297 cm art. CRS54 + n° 2 art. ARCO72  
 from 144 cm to 297 cm

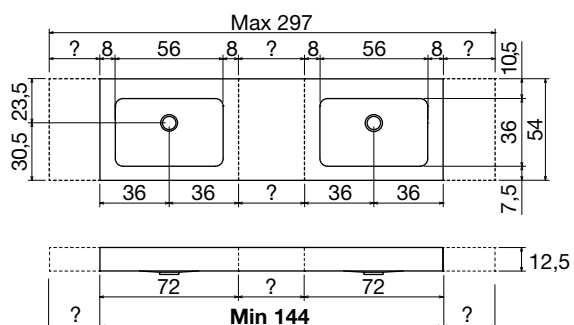

Top con doppio lavabo integrato soprapiano o da parete in Corian spessore 125 mm, completo di piletta con scarico libero e raccordo per sifone.

Top with double integrated sink completely in Corian 125 mm thick complete with drain pipe fitting and open plug which may be wall mounted or used on furniture.



Per collezione / For collection **LUNARIA**

<b>A</b>		12 mm	P 54	L	da 144 cm a 216 cm from 144 cm to 216 cm	<b>art. CR154 + n° 2 art. ARCO72</b>
----------	--	-------	------	---	---	--------------------------------------

Per collezione / For collection **PANTA REI**

<b>B</b>		12 mm	P 54	L	da 144 cm a 216 cm from 144 cm to 216 cm	<b>art. CR254 + n° 2 art. ARCO72</b>
----------	--	-------	------	---	---	--------------------------------------

Per collezione / For collection **PLANETA**

<b>C</b>		12 mm	P 54	L	da 144 cm a 216 cm from 144 cm to 216 cm	<b>art. CR354 + n° 2 art. ARCO72</b>
----------	--	-------	------	---	---	--------------------------------------

Per collezione / For collection **PIANA - EXELEN**

<b>A</b>		12 mm	P 54	L	da 146,4 cm a 299,4 cm from 146,4 cm to 299,4 cm	<b>art. CR154 + n° 2 art. ARCO72</b>
----------	--	-------	------	---	---	--------------------------------------

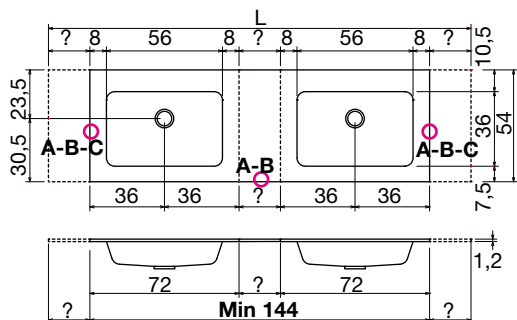

Top con doppio lavabo integrato sopraiano in Corian, spess. 12 mm completo di piletta con scarico libero e raccordo per sifone.

**N.B.** solo per porta lavabi H 37,5 e H 50 cm. Nei porta lavabi H 37,5 è possibile inserire solo sifone art. MICRO.

Top with double integrated sink completely in Corian 12 mm thick, complete with drain pipe fitting and open plug.

**P.S.** only for sink units cm 37,5 H and 50 H. In sink units cm 37,5 H it is only possible to use siphon art. MICRO.



Per collezione / For collection **LUNARIA**

<b>A</b>		12 mm	P	L	da 72 cm a 216 cm from 72 cm to 216 cm	<b>art. CR154 + art. SASSO72</b>
			54			

Per collezione / For collection **PANTA REI**

<b>B</b>		12 mm	P	L	da 72 cm a 216 cm from 72 cm to 216 cm	<b>art. CR254 + art. SASSO72</b>
			54			

Per collezione / For collection **PLANETA**

<b>C</b>		12 mm	P	L	da 72 cm a 216 cm from 72 cm to 216 cm	<b>art. CR354 + art. SASSO72</b>
			54			

Per collezione / For collection **PIANA - EXELEN**

<b>A</b>		12 mm	P	L	da 74,4 cm a 299,4 cm from 74,4 cm to 299,4 cm	<b>art. CR154 + art. SASSO72</b>
			54			

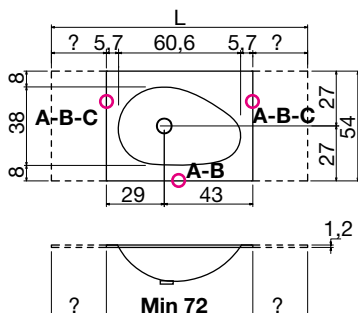

Top con lavabo integrato sopra piano in Corian spessore 12 mm completo di piletta con scarico libero e raccordo per sifone.

**N.B.** solo per porta lavabi H 37,5 e H 50 cm. Nei porta lavabi H 37,5 è possibile inserire solo sifone art. MICRO.

Top with integrated sink completely in Corian 12 mm thick, complete with drain pipe fitting and open plug.

**P.S.** only for sink units cm 37,5 and 50 H. In sink units cm 37,5 H it is only possible to use siphon art. MICRO.



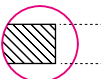

Per collezione / For collection **LUNARIA**

**A**  12 mm 54 P L  
da 144 cm a 216 cm **art. CR154 + n° 2 art. SASSO72**  
from 144 cm to 216 cm

Per collezione / For collection **PANTA REI**

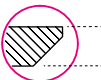
**B**  12 mm 54 P L  
da 144 cm a 216 cm **art. CR254 + n° 2 art. SASSO72**  
from 144 cm to 216 cm

Per collezione / For collection **PLANETA**

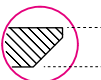
**C**  12 mm 54 P L  
da 144 cm a 216 cm **art. CR354 + n° 2 art. SASSO72**  
from 144 cm to 216 cm

Per collezione / For collection **PIANA - EXELEN**

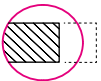
**A**  12 mm 54 P L  
da 146,4 cm a 299,4 cm **art. CR154 + n° 2 art. SASSO72**  
from 146,4 cm to 299,4 cm

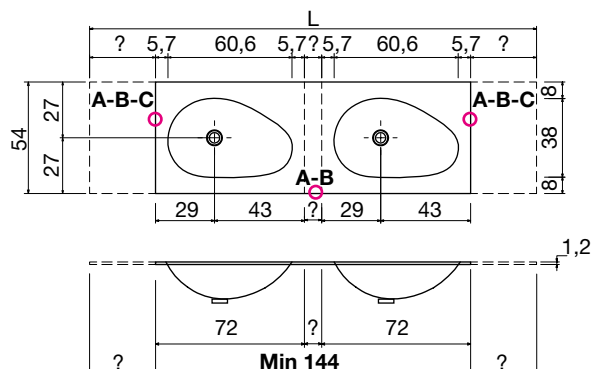

Top con doppio lavabo integrato sopraiano in Corian spessore 12 mm, completo di piletta con scarico libero e raccordo per sifone.

**N.B.** Solo per porta lavabi H 37,5 e H 50 cm. Nei porta lavabi H 37,5 è possibile inserire solo sifone art. MICRO.

Top with double integrated sink completely in Corian 12 mm thick, with drain pipe fitting and open plug.

**P.S.** only for sink units cm 37,5 H and 50 H. In sink units cm 37,5 H it is only possible to use siphon art. MICRO.

# SASSO



P 54 L da 72 cm a 297 cm art. CRS54 + art. SASSO72  
 from 72 cm to 297 cm

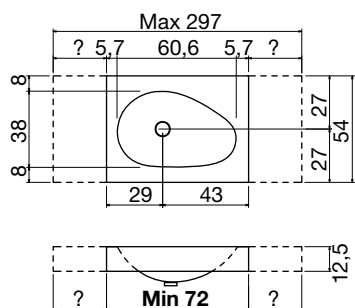

Top con lavabo integrato sopra piano o da parete in Corian spessore 125 mm, completo di piletta con scarico libero e raccordo per sifone.

*Top with integrated sink completely in Corian 125 mm thick complete with drain pipe fitting and open plug which may be wall mounted or used on furniture.*

# SASSO



P 54 L da 144 cm a 297 cm art. CRS54 + n° 2 art. SASSO72  
 from 144 cm to 297 cm

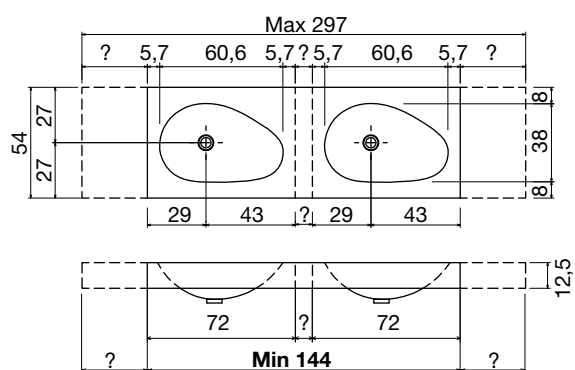

Top con doppio lavabo integrato soprapiano o da parete in Corian spessore 125 mm, completo di piletta con scarico libero e raccordo per sifone.

Top with double integrated sink completely in Corian 125 mm thick complete with drain pipe fitting and open plug which may be wall mounted or used on furniture.







Per collezione / For collection **LUNARIA**

**A**  12 mm P 54 L da 72 cm a 216 cm  
from 72 cm to 216 cm **art. CR154 + art. BACINO72**

Per collezione / For collection **PANTA REI**

**B**  12 mm P 54 L da 72 cm a 216 cm  
from 72 cm to 216 cm **art. CR254 + art. BACINO72**

Per collezione / For collection **PLANETA**

**C**  12 mm P 54 L da 72 cm a 216 cm  
from 72 cm to 216 cm **art. CR354 + art. BACINO72**

Per collezione / For collection **PIANA - EXELEN**

**A**  12 mm P 54 L da 74,4 cm a 299,4 cm  
from 74,4 cm to 299,4 cm **art. CR154 + art. BACINO72**

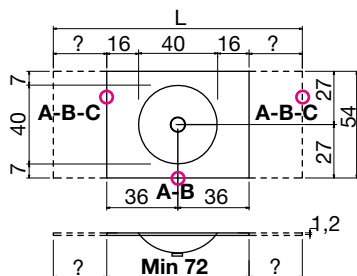

Top con lavabo integrato sopraiano in Corian spessore 12 mm completo di piletta con scarico libero e raccordo per sifone.

**N.B.** solo per porta lavabi H 37,5 e H 50 cm. Nei porta lavabi H 37,5 è possibile inserire solo sifone art. MICRO.

Top with integrated sink completely in Corian 12 mm thick, complete with drain pipe fitting and open plug.

**P.S.** only for sink units cm 37,5 and 50 H. In sink units cm 37,5 H it is only possible to use siphon art. MICRO.

# BACINO



Per collezione / For collection **LUNARIA**

<b>A</b>		P	L	<b>art. CR154 + n° 2 art. BACINO72</b>
		12 mm 54	da 144 cm a 216 cm from 144 cm to 216 cm	

Per collezione / For collection **PANTA REI**

<b>B</b>		P	L	<b>art. CR254 + n° 2 art. BACINO72</b>
		12 mm 54	da 144 cm a 216 cm from 144 cm to 216 cm	

Per collezione / For collection **PLANETA**

<b>C</b>		P	L	<b>art. CR354 + n° 2 art. BACINO72</b>
		12 mm 54	da 144 cm a 216 cm from 144 cm to 216 cm	

Per collezione / For collection **PIANA - EXELEN**

<b>A</b>		P	L	<b>art. CR154 + n° 2 art. BACINO72</b>
		12 mm 54	da 146,4 cm a 299,4 cm from 146,4 cm to 299,4 cm	

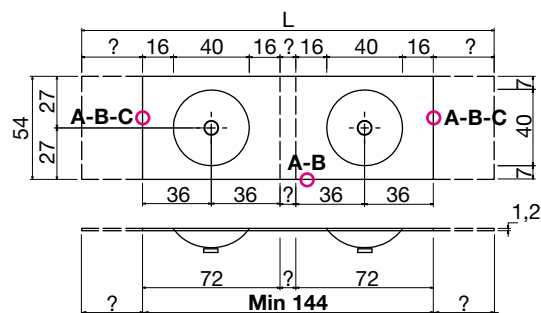

Top con doppio lavabo integrato soprapiano in Corian spessore 12 mm, completo di piletta con scarico libero e raccordo per sifone.

**N.B.** Solo per porta lavabi H 37,5 e H 50 cm. Nei porta lavabi H 37,5 è possibile inserire solo sifone art. MICRO.

Top with double integrated sink completely in Corian 12 mm thick, with drain pipe fitting and open plug.

**P.S.** only for sink units cm 37,5 H and 50 H. In sink units cm 37,5 H it is only possible to use siphon art. MICRO.

# BACINO



P 54 L da 72 cm a 297 cm **art. CRS54 + art. BACINO72**  
 from 72 cm to 297 cm

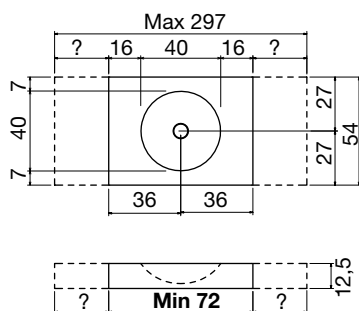

Top con lavabo integrato sopra piano o da parete in Corian spessore 125 mm, completo di piletta con scarico libero e raccordo per sifone.

*Top with integrated sink completely in Corian 125 mm thick complete with drain pipe fitting and open plug.*



# BACINO



P 54 L da 144 cm a 297 cm art. CRS54 + n° 2 art. BACINO72  
 from 144 cm to 297 cm

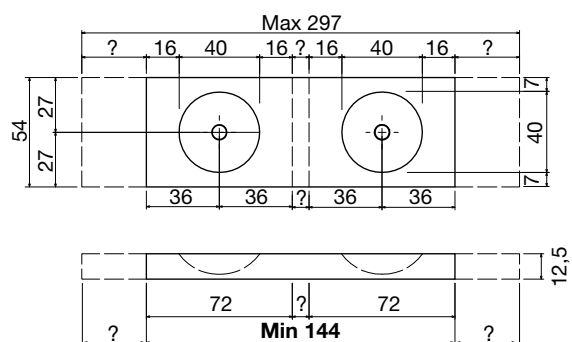

Top con doppio lavabo integrato soprapiano o da parete in Corian spessore 125 mm, completo di piletta con scarico libero e raccordo per sifone.

Top with double integrated sink completely in Corian 125 mm thick complete with drain pipe fitting and open plug which may be wall mounted or used on furniture.



# LAVABI / SINKS

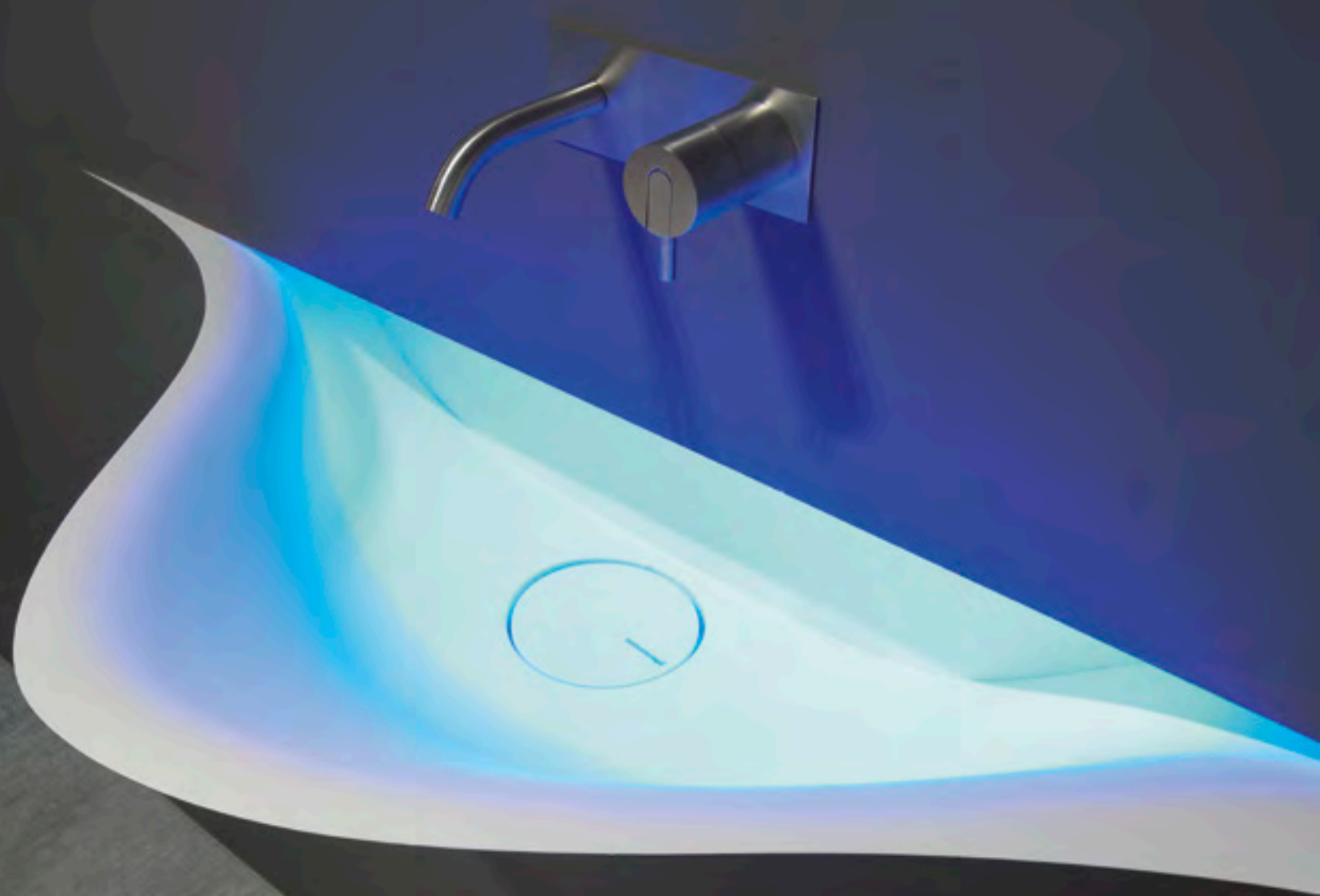



**SILENZIO** design Domenico De Palo

Modello e design registrato, brevetto depositato  
*Registered model and design, patent filed*









# SILENZIO



art. SILENZIO / SILENZIOL

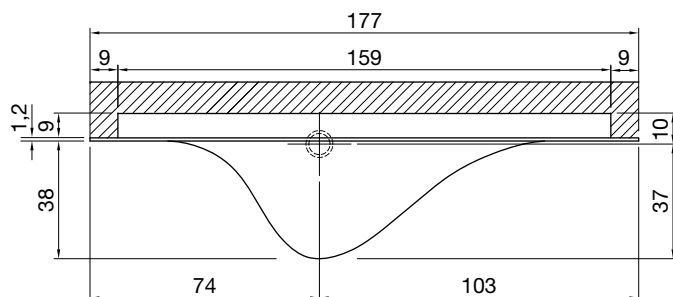
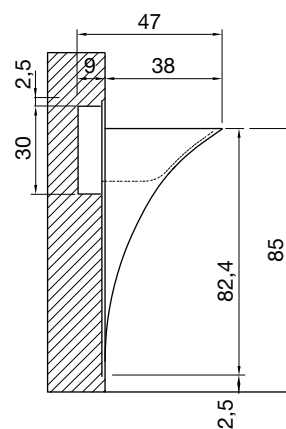
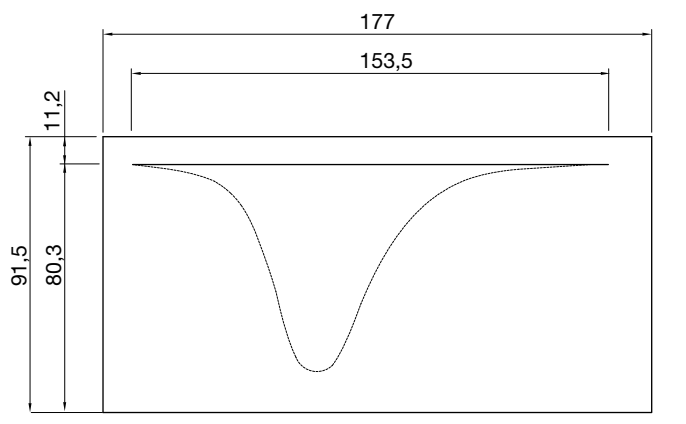

Lavabo da incasso a parete in Corian, con o senza illuminazione a led, completo di piletta ispezionabile, sifone e tubo flessibile.

*Encased Corian sink with or without led lighting, complete with inspectable drain, trap and flexible hose.*

**SOFFIO** design Domenico De Palo

**Modello e design registrato, brevetto depositato**  
*Registered model and design, patent filed*







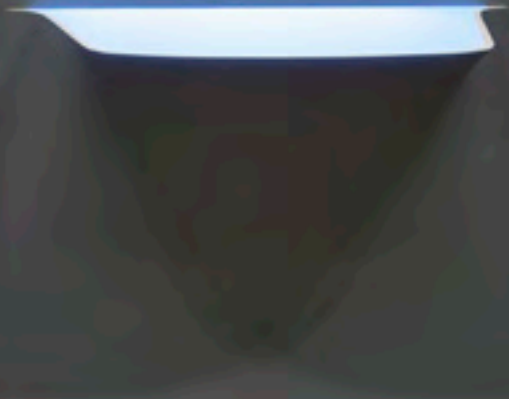
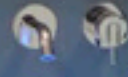

# SOFFIO



art. SOFFIO / SOFFIOL

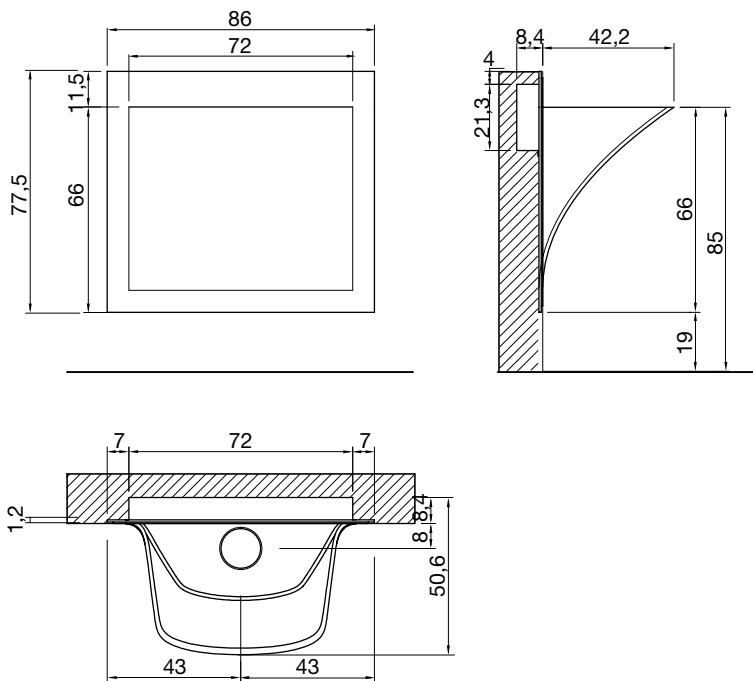

Lavabo da incasso a parete in Corian, con o senza illuminazione a led, completo di piletta ispezionabile, sifone e tubo flessibile.

*Encased Corian sink with or without led lighting, complete with inspectable drain, trap and flexible hose.*

**STRAPPO** design Domenico De Palo

**Modello e design registrato, brevetto depositato**  
*Registered model and design, patent filed*

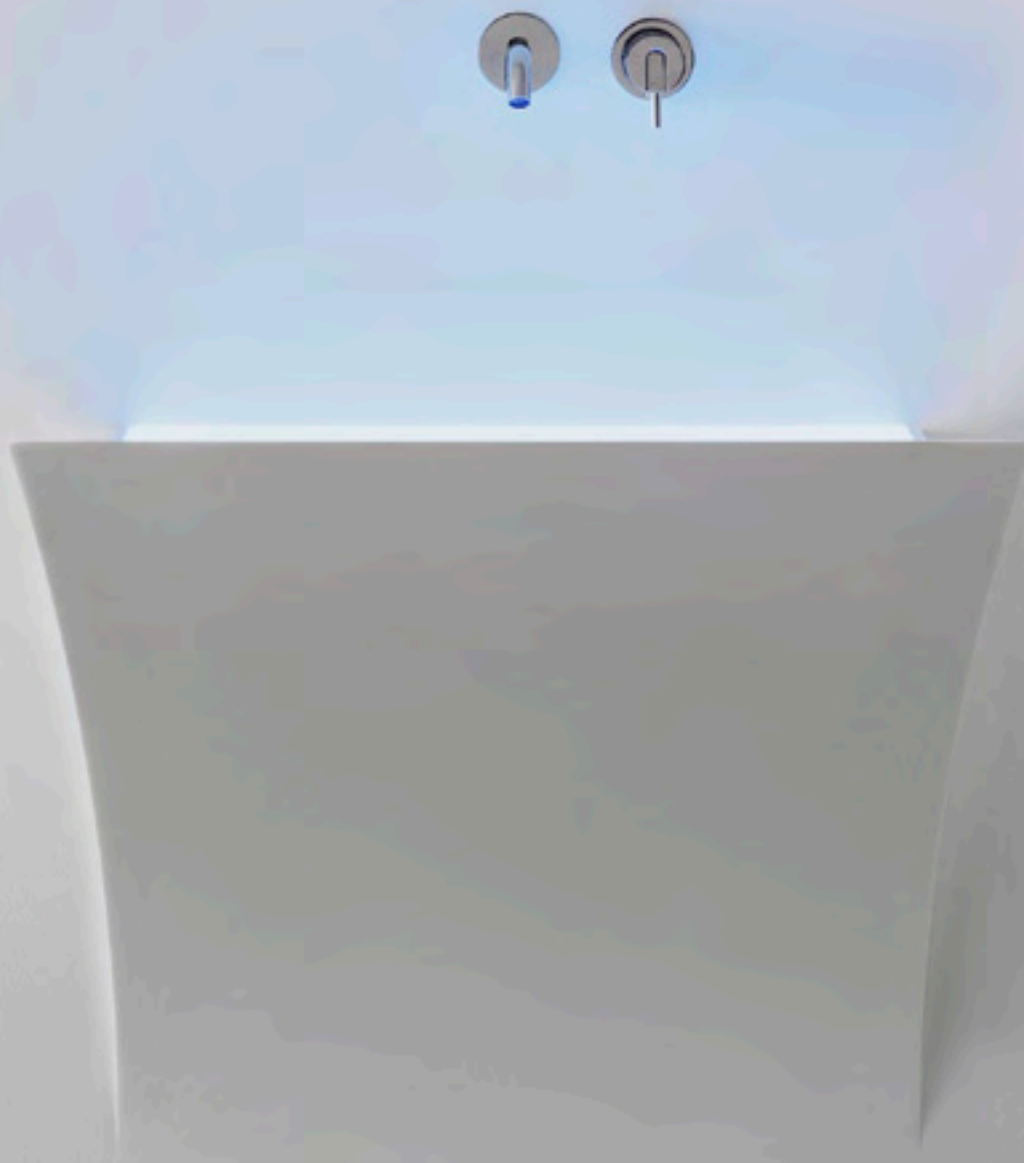



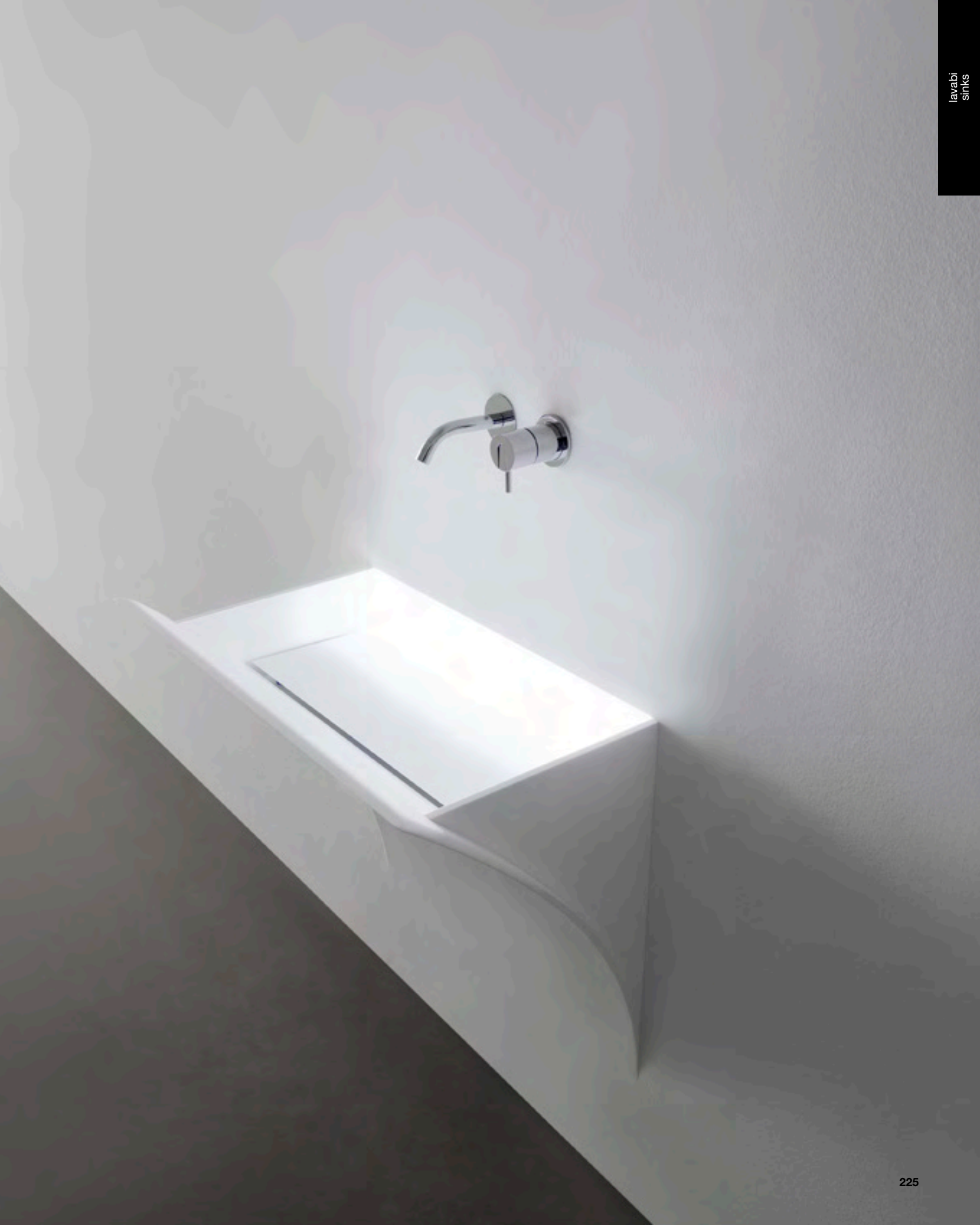



# STRAPPO



art. STRAPPO / STRAPPOL

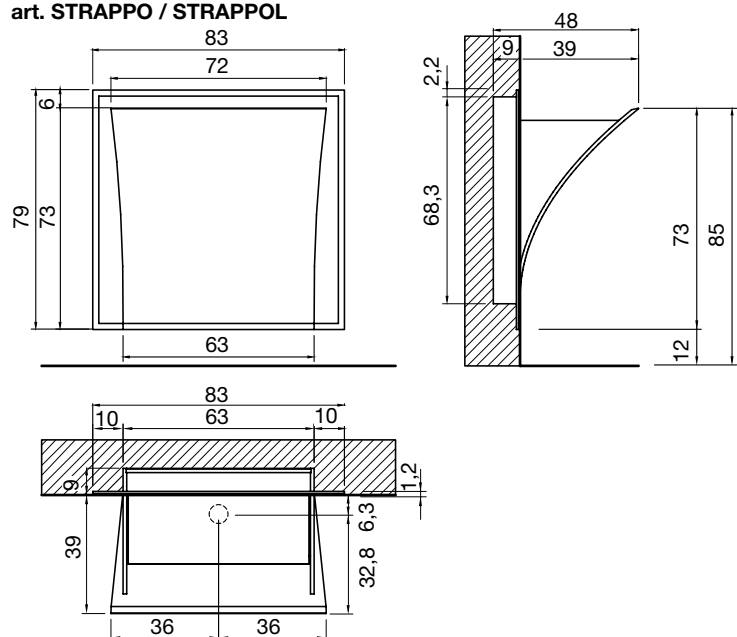

Lavabo da incasso a parete in Corian, con o senza illuminazione a led, completo di piletta ispezionabile, sifone e tubo flessibile.

*Encased Corian sink with or without led lighting, complete with inspectable drain, trap and flexible hose.*



# STRAPPO





SOFFIO





SILENZIO

lavabi  
sinks



**FUORISTRAPPO** design Domenico De Palo

**Modello e design registrati, brevetto depositato**  
*Registered model and design, patent pending*

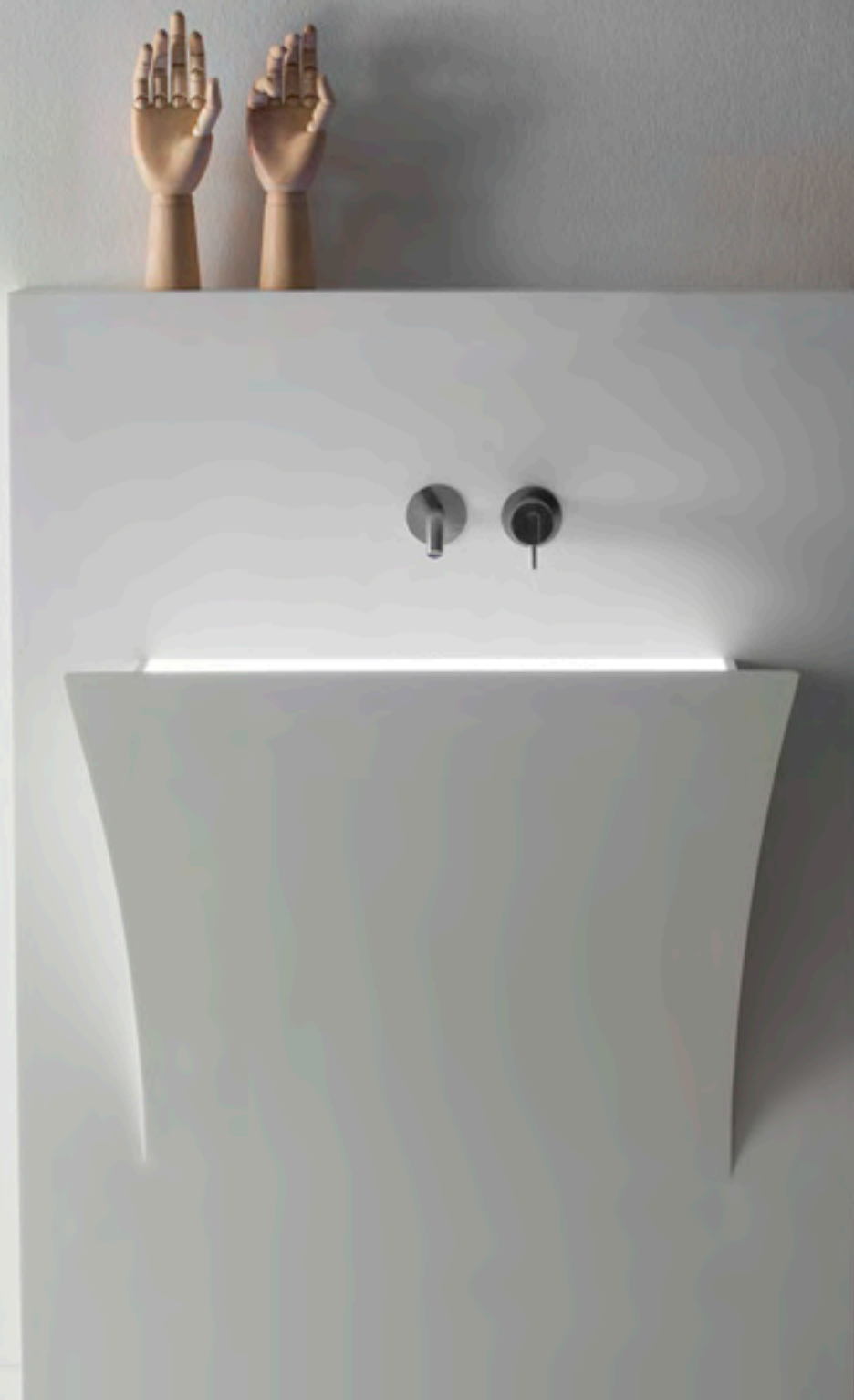







# FUORISTRAPPO



art. FUORISTRAPPO / FUORISTRAPPOL

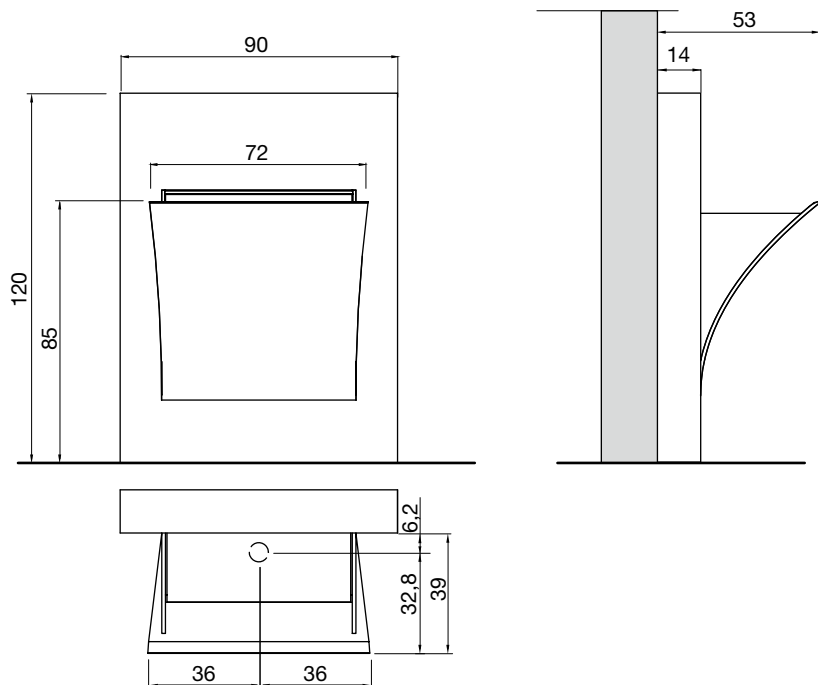

Lavabo a parete in Corian, con o senza illuminazione a led, completo di pileta ispezionabile, sifone e tubo flessibile.

Wall mount Corian sink with or without lighting, complete with inspection drain, trap and flexible hose.





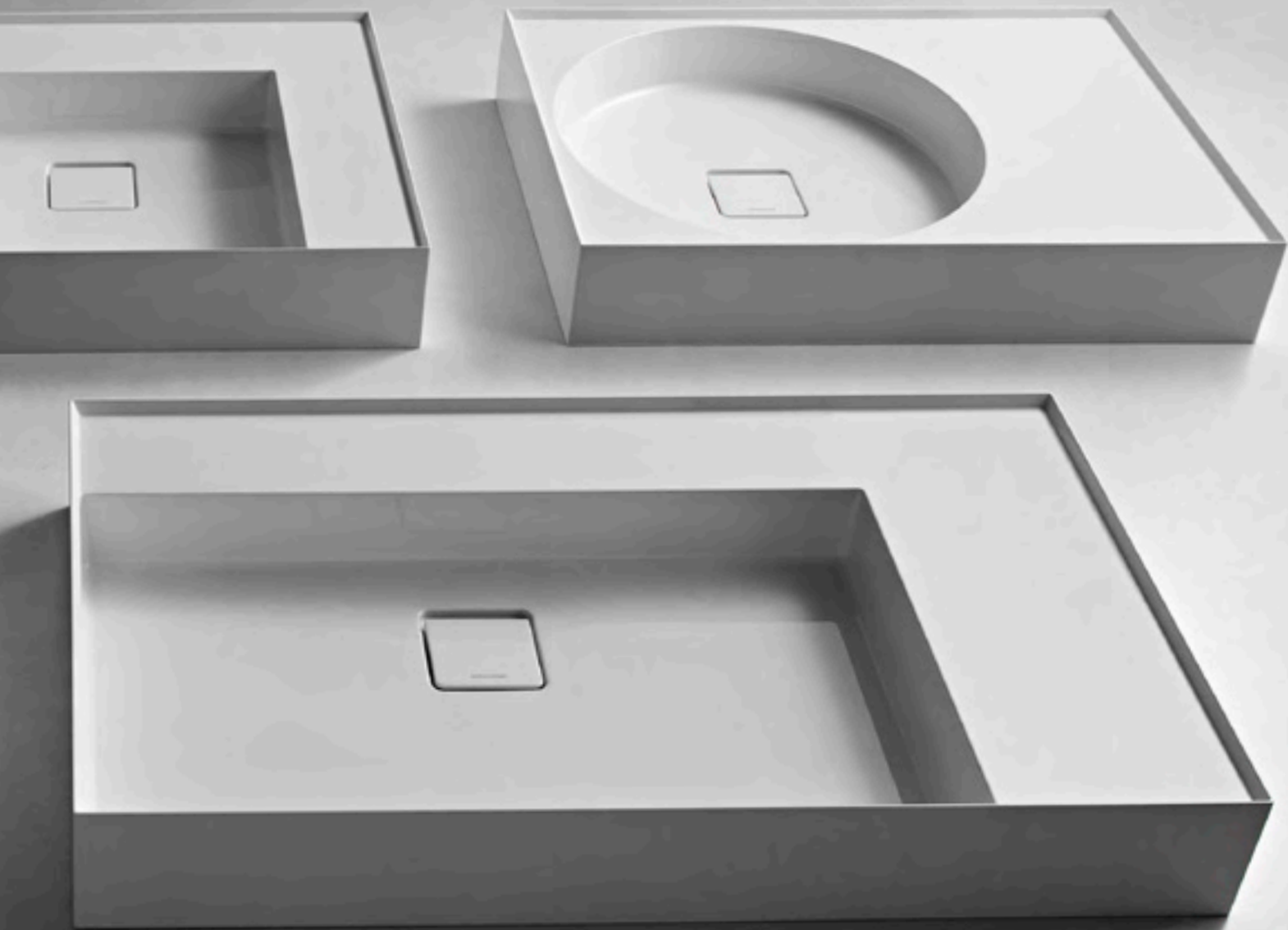

# GRAFFIO



art. GRAFFIO38

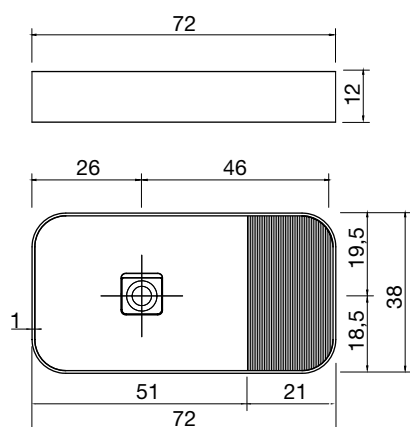
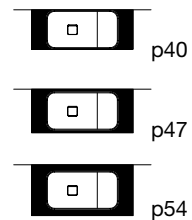

Lavabo rettangolare sopra piano in Ceramilux con ripiano, completo di piletta con scarico libero e raccordo per sifone.

Rectangular top mount Ceramilux sink with shelf, complete with open drain and drain pipe fitting.

# GRAFFIO



art. GRAFFIO72

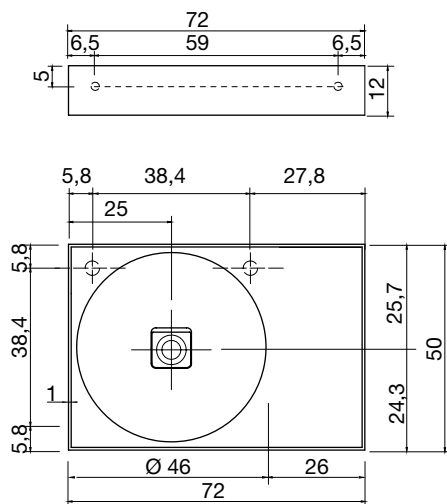
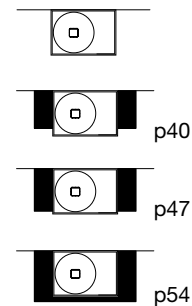

Lavabo rettangolare sopra piano o da parete in Ceramilux con ripiano, completo di piletta con scarico libero e raccordo per sifone.

Rectangular top mount or wall mount Ceramilux sink with shelf, complete with open drain and drain pipe fitting.



# GRAFFIO



art. GRAFFIO54

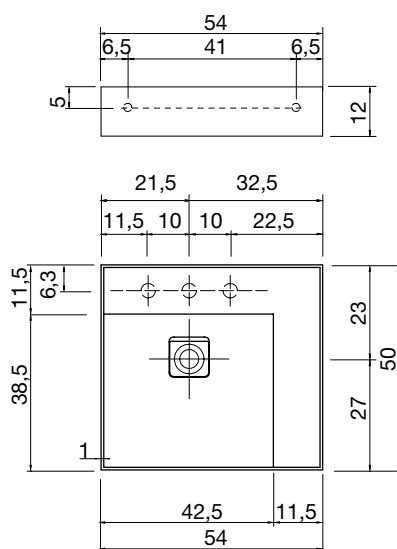
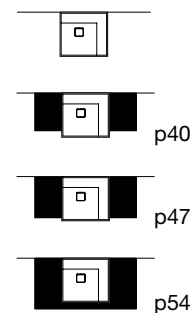

Lavabo rettangolare sopra piano o da parete in Ceramilux con ripiano, completo di piletta con scarico libero e raccordo per sifone.

Rectangular top mount or wall mount Ceramilux sink with shelf, complete with open drain and drain pipe fitting.

# GRAFFIO



art. GRAFFIO90

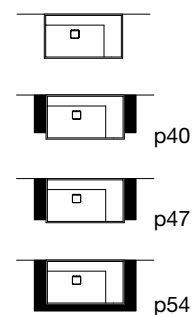
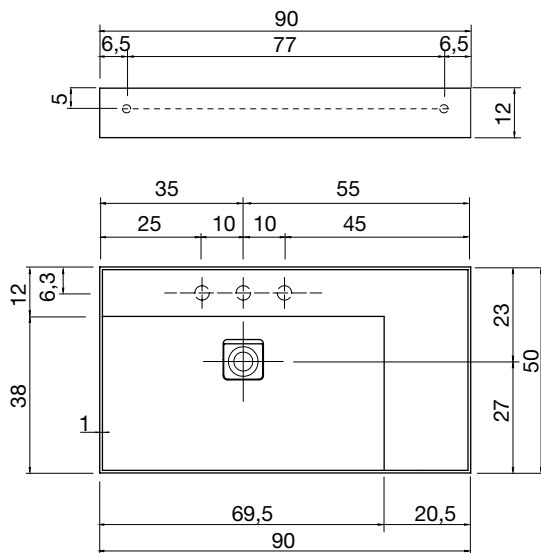

Lavabo rettangolare sopra piano o da parete in Ceramilux con ripiano, completo di piletta con scarico libero e raccordo per sifone.

Rectangular top mount or wall mount Ceramilux sink with shelf, complete with open drain and drain pipe fitting.

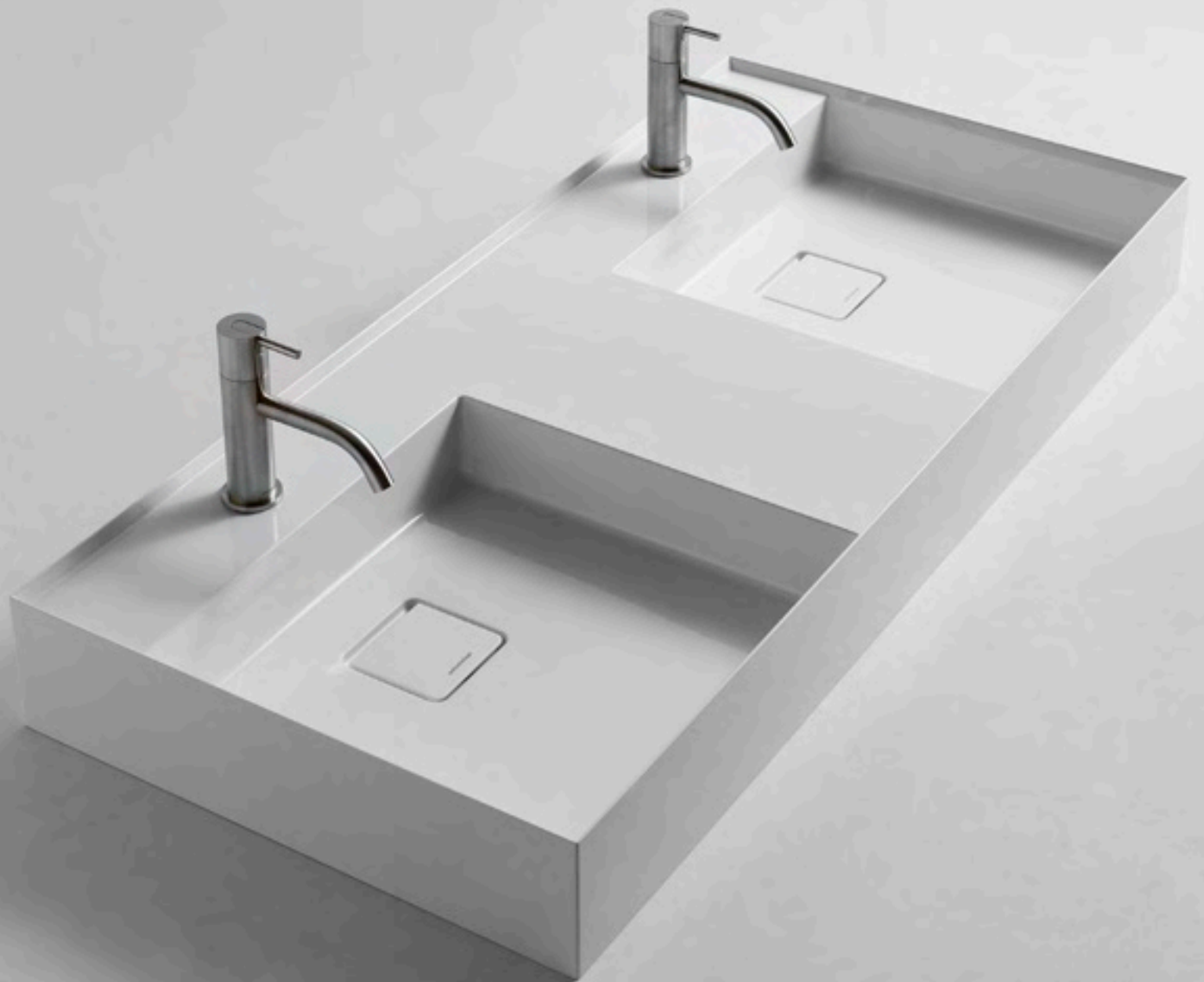



# GRAFFIO



art. GRAFFIO108

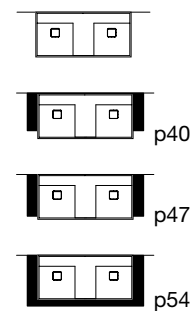
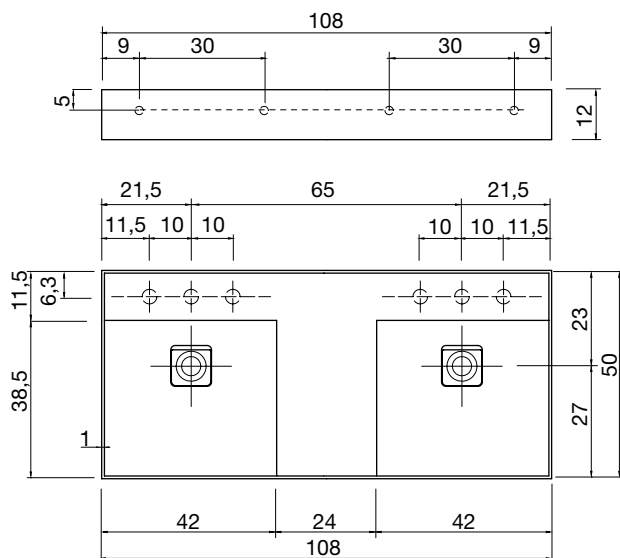

Lavabo rettangolare sopra piano o da parete in Ceramilux con ripiano, completo di piletta con scarico libero e raccordo per sifone.

Rectangular top mount or wall mount Ceramilux sink with shelf, complete with open drain and drain pipe fitting.





art. GESTO54

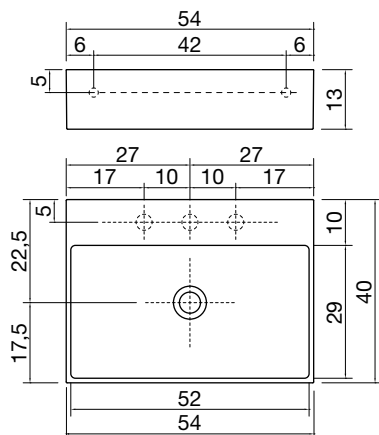
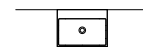

Lavabo rettangolare sopra piano o da parete in Ceramilux lucido, completo di piletta con scarico libero e raccordo per sifone.

Rectangular top mount or wall mount glossy Ceramilux sink, complete with drain pipe fitting and open plug.









art. GESTO63

art. GESTO90

GESTO63

GESTO90

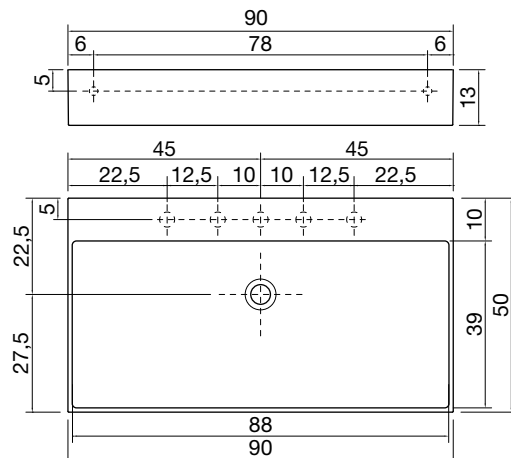
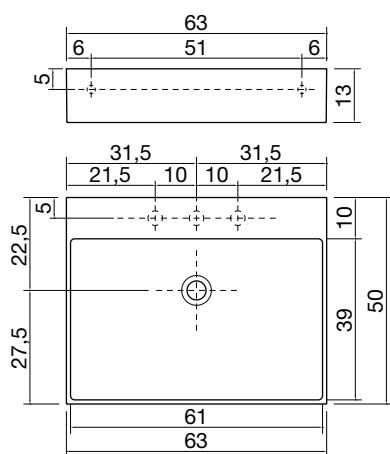
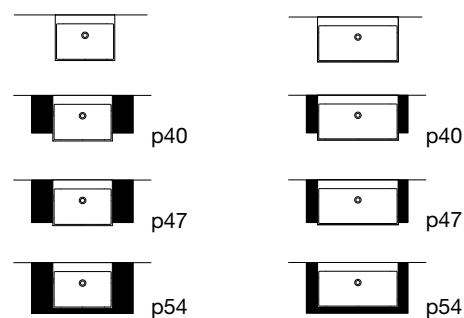

Lavabo rettangolare sopraiano o da parete in Ceramilux lucido o opaco, completo di piletta con scarico libero e raccordo per sifone.

Rectangular top mount or wall mount glossy or matt Ceramilux sink, complete with drain pipe fitting and open plug.





# GESTO



art. GESTO126

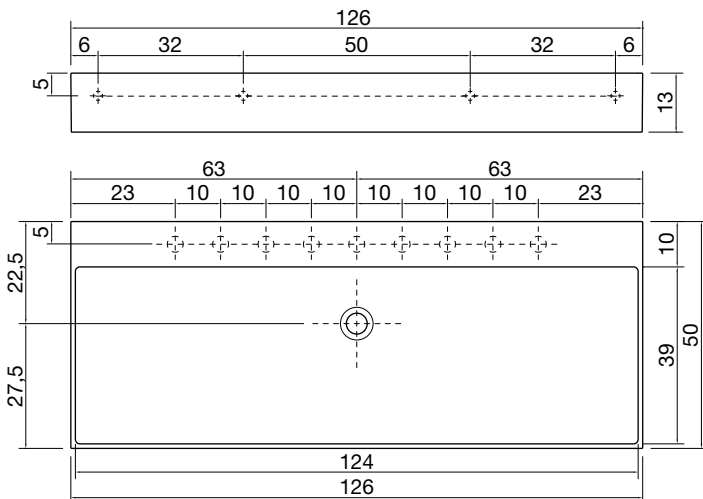
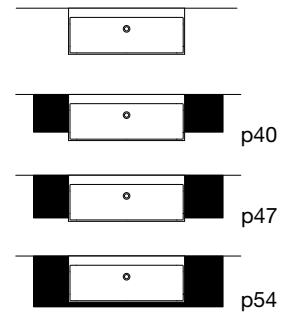

Lavabo rettangolare sopraiano o da parete in Ceramilux lucido o opaco, completo di piletta con scarico libero e raccordo per sifone.

*Rectangular top mount or wall mount glossy or matt Ceramilux sink, complete with drain pipe fitting and open plug.*







art. ELETTRA / ELETTRACH

N° 2 prese di corrente opzionali per Art. SLIM.

*N° 2 optional sockets for Art. SLIM.*

art. GESTO54 Lavabo / Sink

art. GESTO12454 Portalavabo / Sink unit

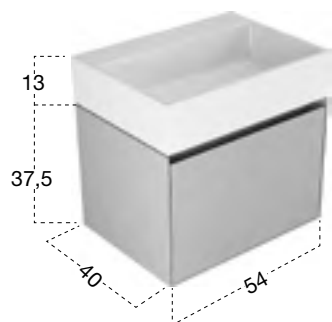

H	P	L	art.
13	40	54	<b>GESTO54</b>

Lavabo rettangolare sopra piano o da parete in Ceramilux lucido completo di piletta con scarico libero e raccordo per sifone.

*Rectangular top mount or wall mount glossy Ceramilux sink complete with drain pipe fitting and open plug.*

H	P	L	art.
37,5	40	54	<b>GESTO12454</b>

Portalavabo con 1 cassetto Art. SLIM, abbinabile solo con lavabo Art. GESTO54.

*Sink unit with 1 drawer Art. SLIM to be combined with Art. GESTO54 sink.*





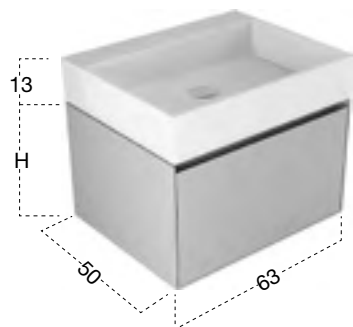

H	P	L	art.
13	50	63	<b>GESTO63</b>

Lavabo rettangolare sopraiano o da parete in Ceramilux lucido o opaco completo di piletta con scarico libero e raccordo per sifone.

*Rectangular top mount or wall mount glossy or matt Ceramilux sink complete with drain pipe fitting and open plug.*

H	P	L	art.
37,5	50	63	<b>GESTO12563</b>
50	50	63	<b>GESTO13563</b>

Porta lavabo con 1 cassetto Art. SLIM, abbinabile solo con lavabo Art. GESTO63.

*Sink unit with a Art. SLIM drawer to be combined with sink Art. GESTO63.*

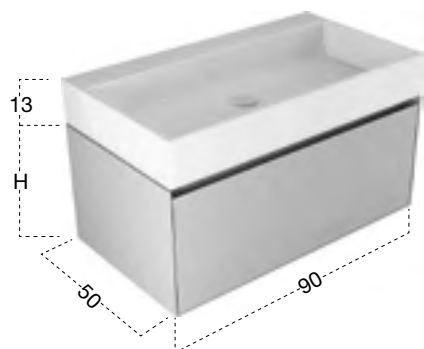

H	P	L	art.
13	50	90	<b>GESTO90</b>

Lavabo rettangolare sopraiano o da parete in Ceramilux lucido o opaco completo di piletta con scarico libero e raccordo per sifone.

*Rectangular top mount or wall mount glossy or matt Ceramilux sink complete with drain pipe fitting and open plug.*

H	P	L	art.
37,5	50	90	<b>GESTO12590</b>
50	50	90	<b>GESTO13590</b>

Porta lavabo con 1 cassetto Art. SLIM, abbinabile solo con lavabo Art. GESTO90.

*Sink unit with a Art. SLIM drawer to be combined with sink Art. GESTO90.*



H	P	L	art.
13	50	126	<b>GESTO126</b>

Lavabo rettangolare sopraiano o da parete in Ceramilux lucido o opaco completo di piletta con scarico libero e raccordo per sifone.

*Rectangular top mount or wall mount glossy or matt Ceramilux sink complete with drain pipe fitting and open plug.*

H	P	L	art.
37,5	50	126	<b>GESTO125126</b>
50	50	126	<b>GESTO135126</b>

Porta lavabo con 1 cassetto Art. SLIM, abbinabile solo con lavabo Art. GESTO126.

*Sink unit with a Art. SLIM drawer to be combined with sink Art. GESTO126.*







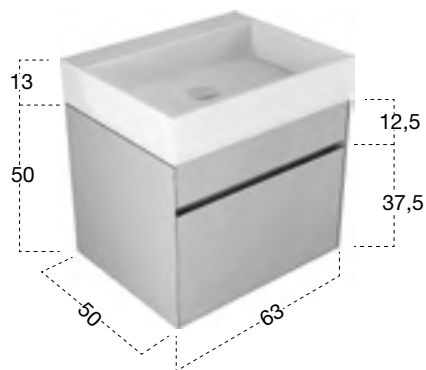

H	P	L	<b>art.</b>
13	50	63	<b>GESTO63</b>

Lavabo rettangolare sopra piano o da parete in Ceramilux lucido o opaco completo di piletta con scarico libero e raccordo per sifone.

*Rectangular top mount or wall mount glossy or matt Ceramilux sink complete with drain pipe fitting and open plug.*

H	P	L	<b>art.</b>
50	50	63	<b>GESTO33563</b>

Porta lavabo con 2 cassetti Art. SLIM di cui 1 sagomato internamente per sifone, abbinabile solo con lavabo Art. GESTO63.

*Sink unit with 2 drawers Art. SLIM, one of which internally shaped for siphon, to be combined with sink Art. GESTO63.*



H	P	L	<b>art.</b>
13	50	90	<b>GESTO90</b>

Lavabo rettangolare sopra piano o da parete in Ceramilux lucido o opaco completo di piletta con scarico libero e raccordo per sifone.

*Rectangular top mount or wall mount glossy or matt Ceramilux sink complete with drain pipe fitting and open plug.*

H	P	L	<b>art.</b>
50	50	90	<b>GESTO33590</b>

Porta lavabo con 2 cassetti Art. SLIM di cui 1 sagomato internamente per sifone, abbinabile solo con lavabo Art. GESTO90.

*Sink unit with 2 drawers Art. SLIM, one of which internally shaped for siphon, to be combined with sink Art. GESTO90.*



H	P	L	<b>art.</b>
13	50	126	<b>GESTO126</b>

Lavabo rettangolare sopra piano o da parete in Ceramilux lucido o opaco completo di piletta con scarico libero e raccordo per sifone.

*Rectangular top mount or wall mount glossy or matt Ceramilux sink complete with drain pipe fitting and open plug.*

H	P	L	<b>art.</b>
50	50	126	<b>GESTO335126</b>

Porta lavabo con 2 cassetti Art. SLIM di cui 1 sagomato internamente per sifone, abbinabile solo con lavabo Art. GESTO126.

*Sink unit with 2 drawers Art. SLIM, one of which internally shaped for siphon, to be combined with sink Art. GESTO126.*





art. ALA72

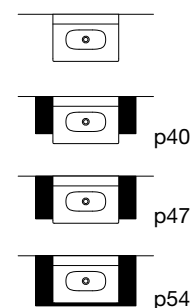
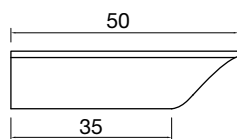
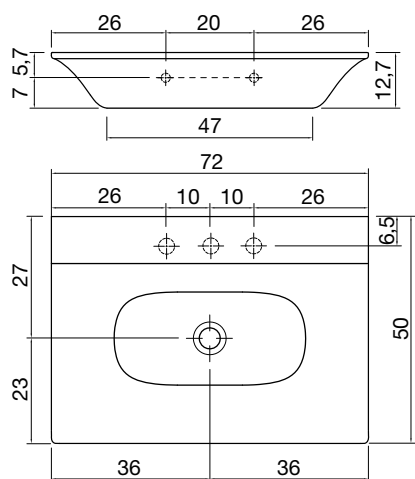

Lavabo rettangolare sopra piano o da parete in Ceramilux, completo di piletta con scarico libero e raccordo per sifone.

Rectangular top mount or wall mount Ceramilux sink, complete with drain pipe fitting and open plug.







art. CORNER

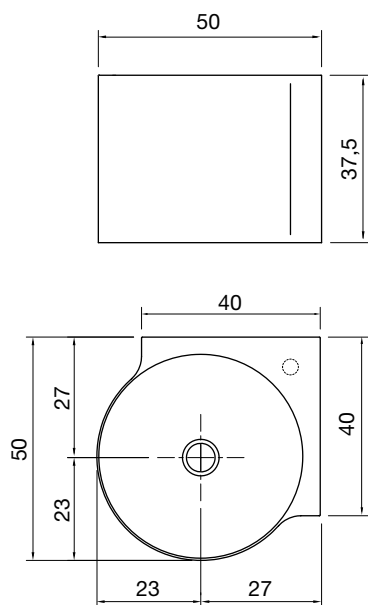

Lavabo angolare sopra piano o da parete in Ceramilux, completo di piletta con scarico libero e raccordo per sifone.

*Ceramilux top or wall mounted corner sink with drain pipe fitting and open plug.*







**BOLO**







# BOLO



**BOLO54**  
54 x 40 x 12,5 cm



**BOLO45**  
Ø 45 cm x 12,5 cm



**BOLO63**  
63 x 40 x 12,5 cm



**BOLO40**  
40 x 40 x 12,5 cm

# BOLO



art. BOLO40



p40



p47



p54

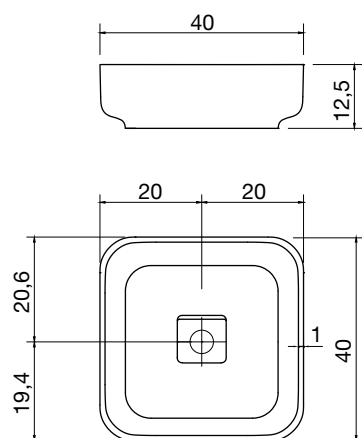

Lavabo quadrato sopra piano in Ceramilux completo di piletta con scarico libero e raccordo per sifone.

*Square top mount Ceramilux sink complete with drain pipe fitting and open plug.*



# BOLO



art. BOLO54



p40



p47



p54

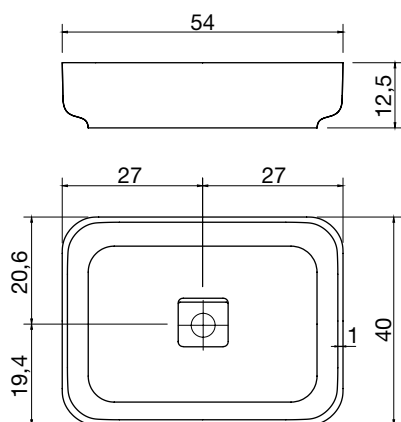

Lavabo rettangolare sopra piano in Ceramilux completo di piletta con scarico libero e raccordo per sifone.

*Rectangular top mount Ceramilux sink complete with drain pipe fitting and open plug.*

# BOLO



art. BOLO45



p40



p47



p54

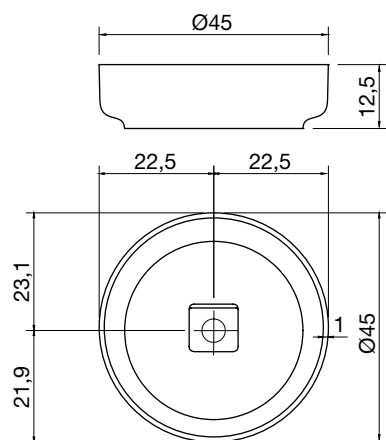

Lavabo tondo sopra piano in Ceramilux completo di piletta con scarico libero e raccordo per sifone.

Round top mount Ceramilux sink complete with drain pipe fitting and open plug.

# BOLO



art. BOLO63

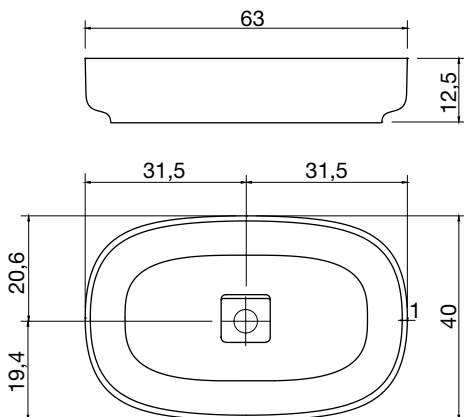

Lavabo ovale sopra piano in Ceramilux completo di piletta con scarico libero e raccordo per sifone.

Oval top mount Ceramilux sink complete with drain pipe fitting and open plug.



BOLO













art. SERVOTONDO



p40



p47



p54

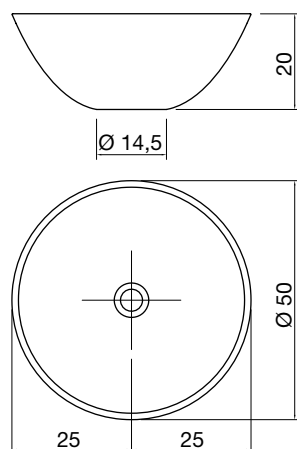

Lavabo tondo sopra piano in Ceramilux, completo di piletta con scarico libero e raccordo per sifone.

Round top mount Ceramilux sink complete with drain pipe fitting and open plug.









art. SERVORETTO50

art. SERVORETTO63

SERVORETTO50

SERVORETTO63

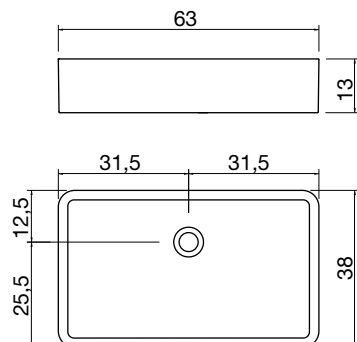
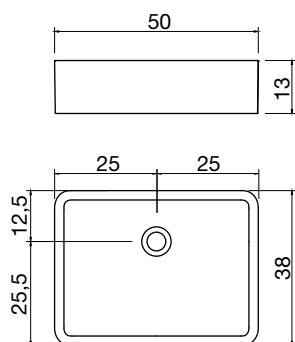

Lavabo rettangolare sopra piano o sottopiano in Ceramilux, completo di piletta con scarico libero e raccordo per sifone.

Rectangular top mount or undermount Ceramilux sink complete with drain pipe fitting and open plug.



# SERVORETTO



art. SERVORETTO50

art. SERVORETTO63

SERVORETTO50

SERVORETTO63

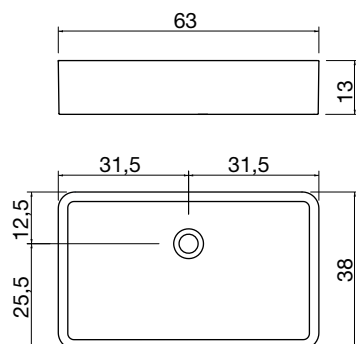
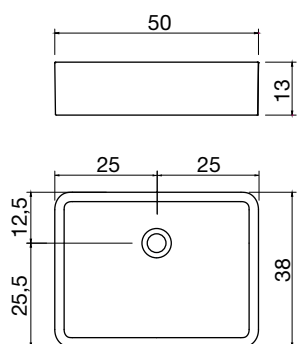
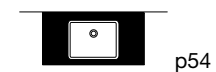

Lavabo rettangolare sopra piano o sottopiano in Ceramilux, completo di piletta con scarico libero e raccordo per sifone.

Rectangular top mount or undermount Ceramilux sink complete with drain pipe fitting and open plug.



art. PIPER1



p54

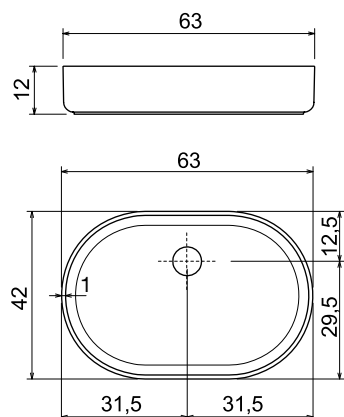

Lavabo ovale sopra piano o sottopiano in Ceramilux completo di piletta con scarico libero e raccordo per sifone.

Oval top or undermount Ceramilux sink, complete with drain pipe fitting and open plug.







# PIPER



art. PIPER1

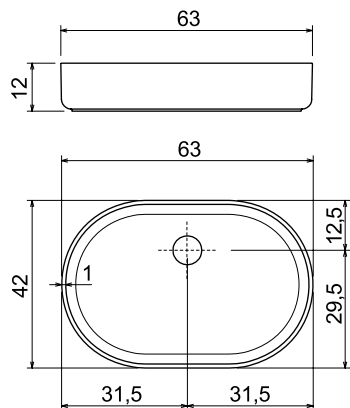
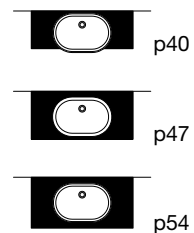

Lavabo ovale sopra piano o sottopiano in Ceramilux completo di piletta con scarico libero e raccordo per sifone.

Oval top or undermount Ceramilux sink, complete with drain pipe fitting and open plug.





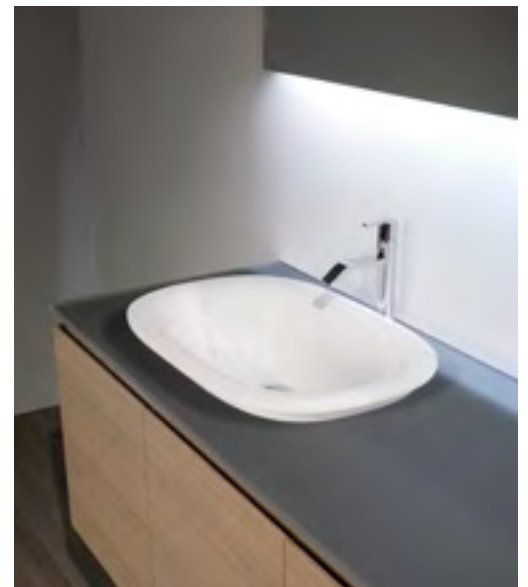
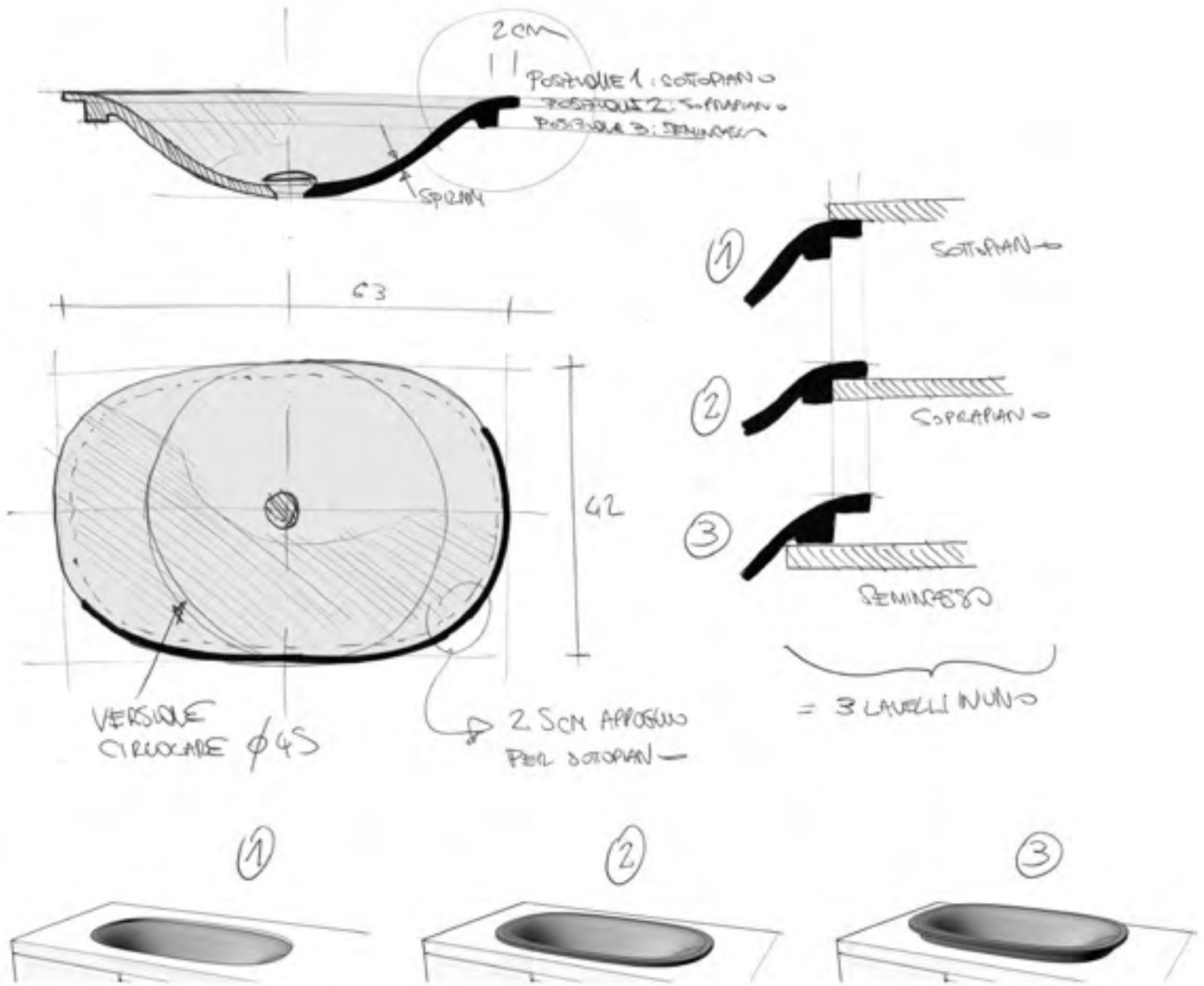





# TRIOVALE



art. TRIOVALE

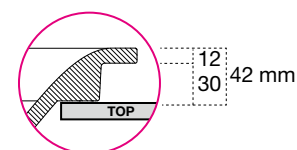
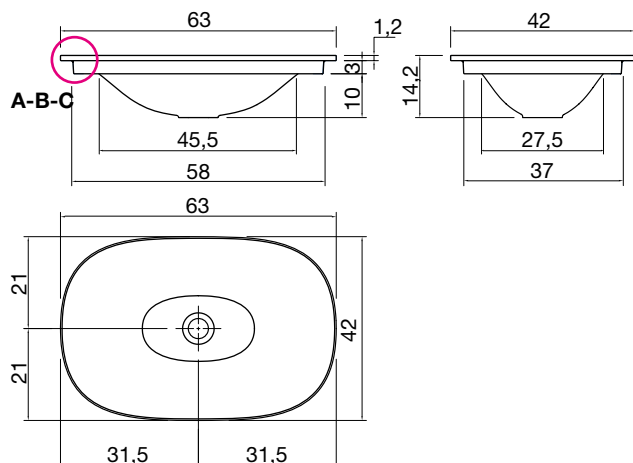
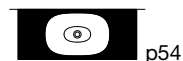

**A**  
**SOPRAPIANO - Encased**

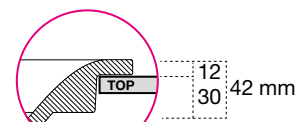

**B**  
**FILOPIANO - Flat edged**

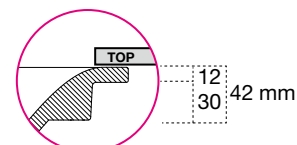

**C**  
**SOTTOPIANO - Undermount**

Lavabo ovale sopra piano ad incasso, filopiano ad incasso o sottopiano in Ceramilux, completo di piletta con scarico libero e raccordo per sifone.

Oval Ceramilux sink which can be encased, flat edged or undermounted complete with drain pipe fitting and open plug.

TRIOVALE









# TRIOTONDO



art. TRIOTONDO

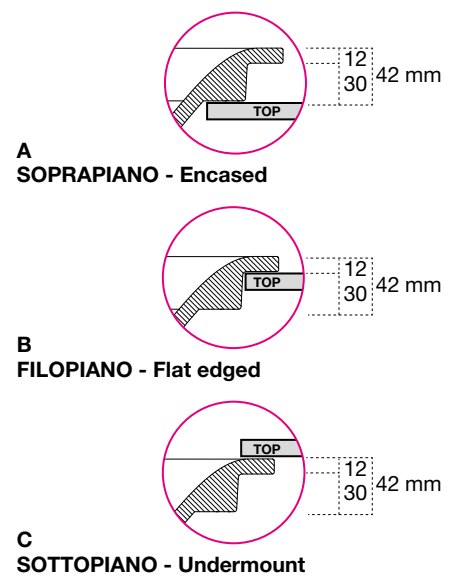
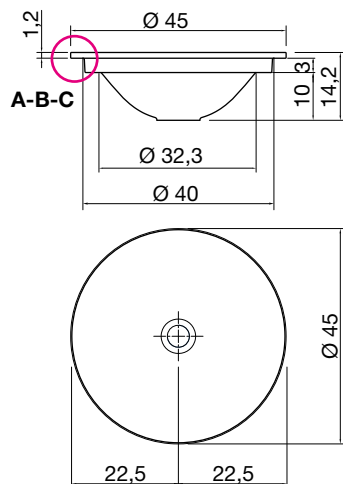

Lavabo tondo sopra piano ad incasso, filopiano ad incasso o sottopiano in Ceramilux, completo di piletta con scarico libero e raccordo per sifone.

Round Ceramilux sink which can be encased, flat edged or undermounted complete with drain pipe fitting and open plug.



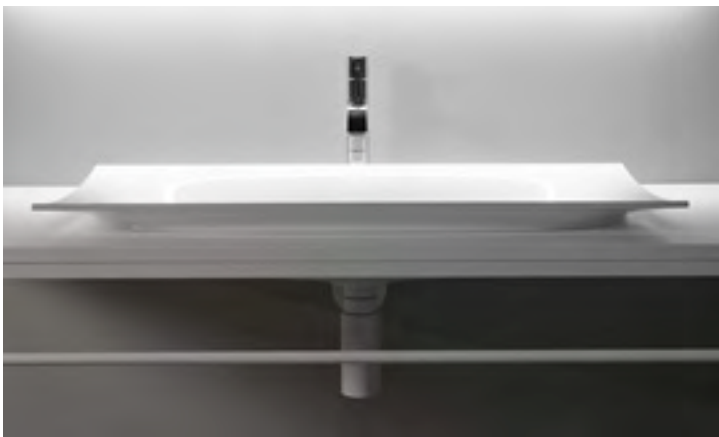
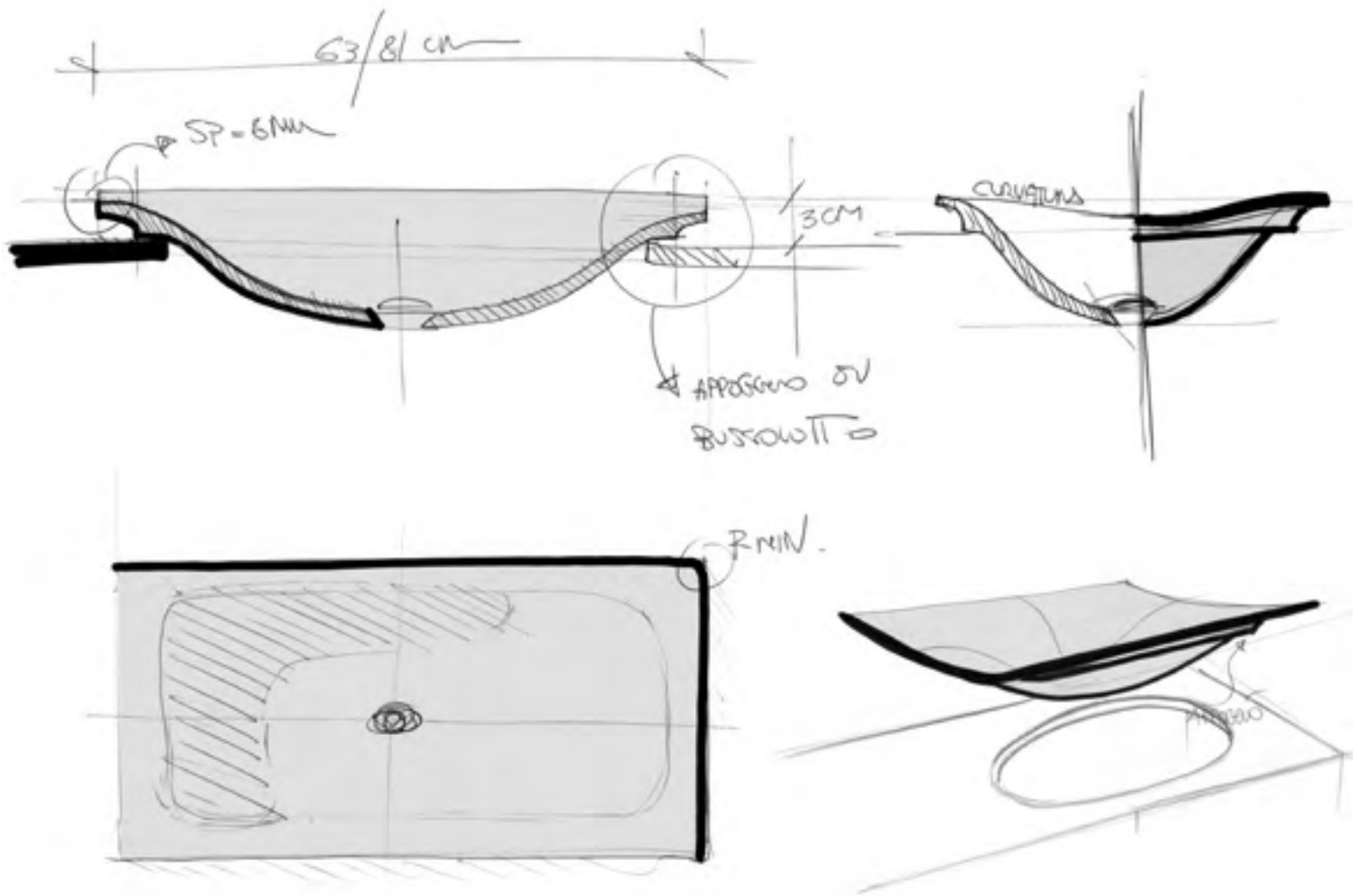



# FOGLIO



art. FOGLIO63

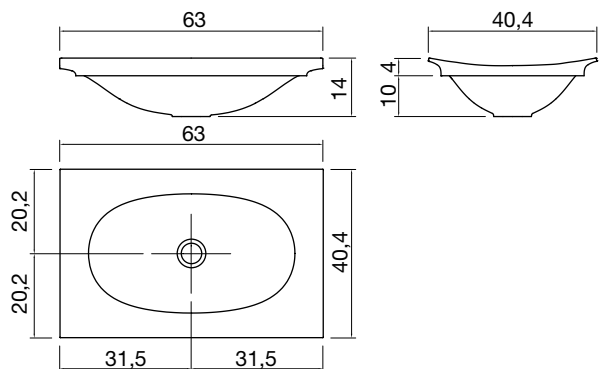

Lavabo rettangolare soprapiano ad incasso in Ceramilux, completo di piletta con scarico libero e raccordo per sifone.

*Rectangular encased Ceramilux sink, complete with drain pipe fitting and open plug.*





art. FOGLIO81

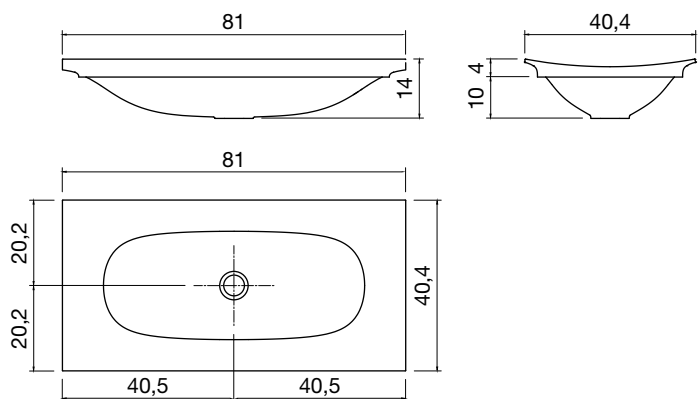

Lavabo rettangolare sopra piano ad incasso in Ceramilux, completo di piletta con scarico libero e raccordo per sifone.

Rectangular encased Ceramilux sink, complete with drain pipe fitting and open plug.





art. BULBO



p47



p54

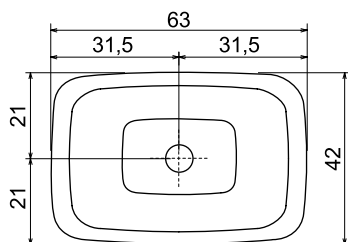
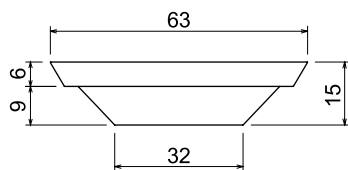

Lavabo rettangolare sopra piano a incasso in Ceramilux completo di piletta con scarico libero e raccordo per sifone.

*Rectangular encased Ceramilux sink, complete with drain pipe fitting and open plug.*





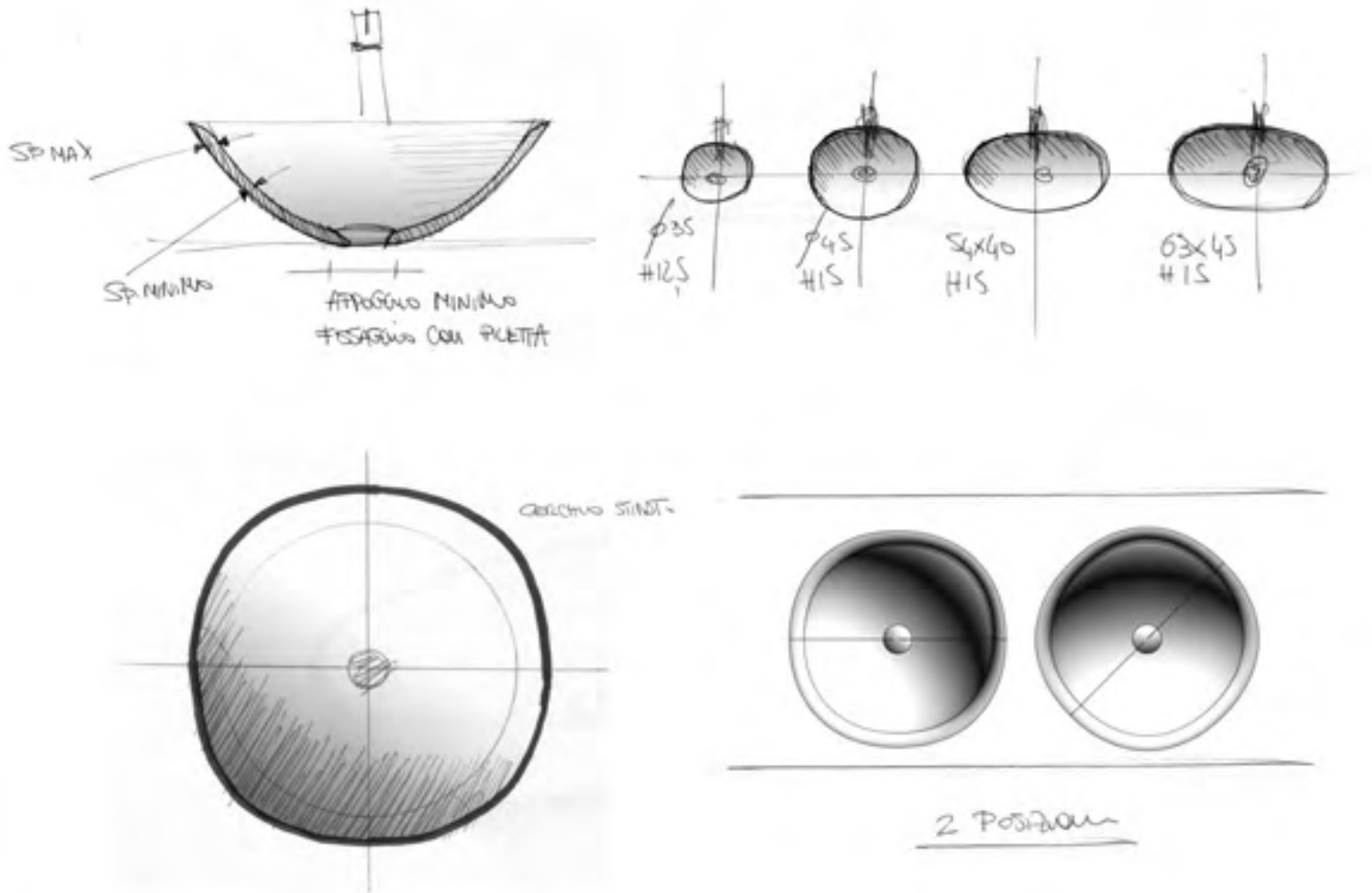







# SERVO



art. SERVO35

art. SERVO45

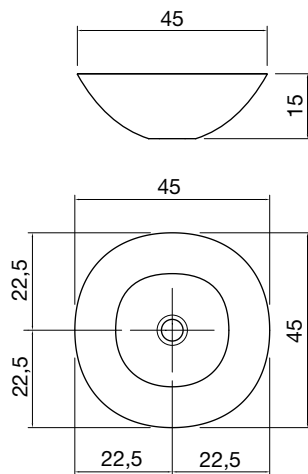
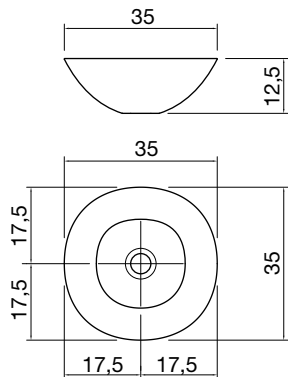

SERVO35

SERVO45



p40



p47



p54

Lavabo tondo sopra piano in Ceramilux, completo di piletta con scarico libero e raccordo per sifone.

Round top mount Ceramilux sink, complete with drain pipe fitting and open plug.

# SERVO



art. SERVO54



p40



p47



p54

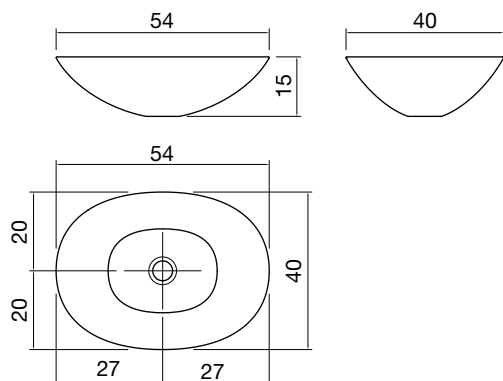

Lavabo ovale sopra piano in Ceramilux, completo di piletta con scarico libero e raccordo per sifone.

Oval top mount Ceramilux sink, complete with drain pipe fitting and open plug.

# SERVO



art. SERVO63

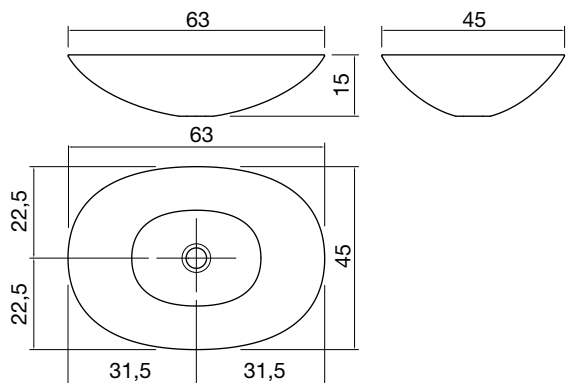

Lavabo ovale sopra piano in Ceramilux, completo di piletta con scarico libero e raccordo per sifone.

Oval top mount Ceramilux sink, complete with drain pipe fitting and open plug.





art. CANYON



p54

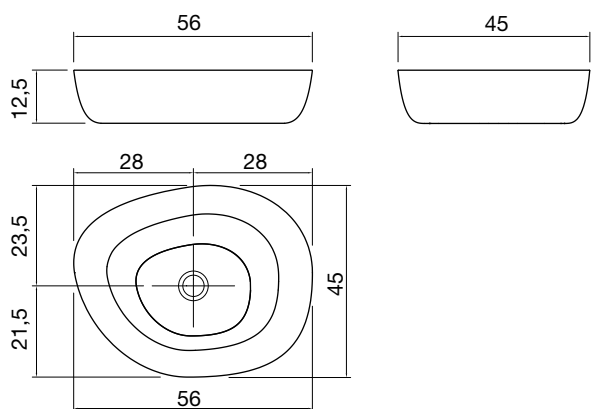

Lavabo tondo sopra piano in Ceramilux, completo di piletta con scarico libero e raccordo per sifone.

*Round top mount Ceramilux sink, complete with drain pipe fitting and open plug.*



art. DUNE



p54

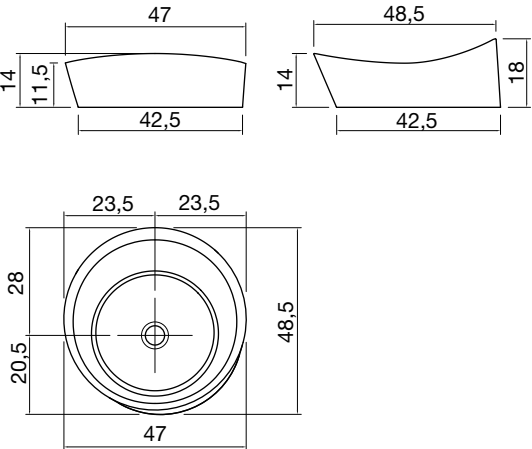

Lavabo tondo sopra piano in Ceramilux, completo di piletta con scarico libero e raccordo per sifone.

Round top mount Ceramilux sink, complete with drain pipe fitting and open plug.







art. **VERSO**

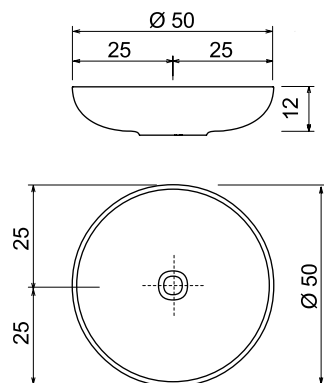
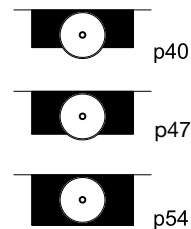

Lavabo tondo sopra piano in Flumood completo di piletta con scarico libero e raccordo per sifone.

*Round top mount Flumood sink complete with drain pipe fitting and open plug.*





art. CATINO



p54

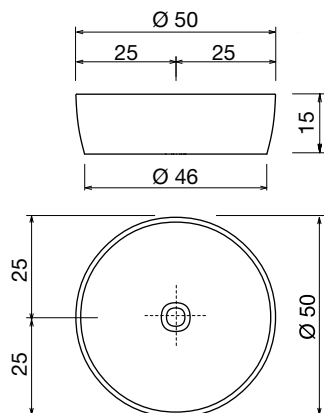

Lavabo tondo sopra piano in Flumood completo di piletta con scarico libero e raccordo per sifone.

*Round top mount Flumood sink complete with drain pipe fitting and open plug.*







art. AGO3



p40



p47



p54

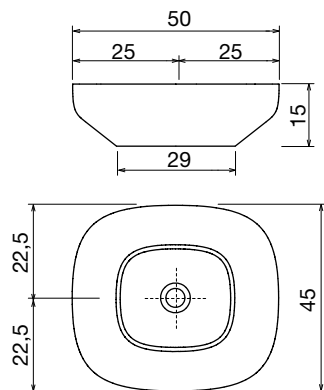

Lavabo ovale sopra piano in Flumood completo di piletta con scarico libero e raccordo per sifone.

Oval top mount Flumood sink complete with drain pipe fitting and open plug.









art. COVO60

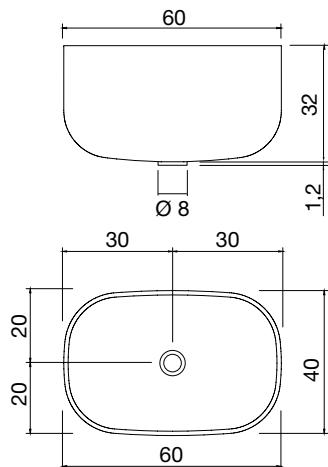
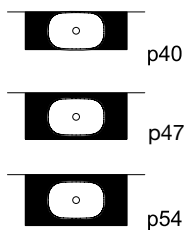

Lavabo rettangolare sopra piano in Corian completo di piletta con scarico libero e raccordo per sifone.

*Rectangular top mount Corian sink complete with drain pipe fitting and open plug.*





art. URNA

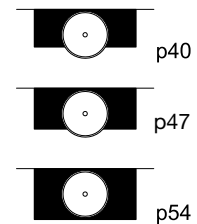
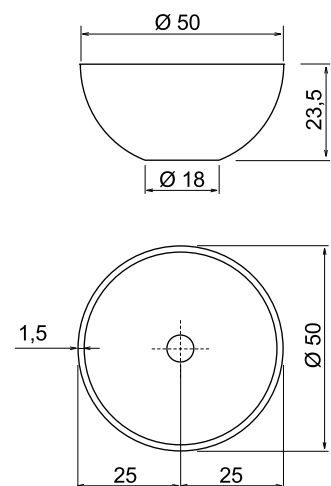

Lavabo tondo sopra piano in Cristalplant biobased completo di piletta con scarico libero e raccordo per sifone.

Round top mount biobased Cristalplant sink complete with drain pipe fitting and open plug.







art. SOLIDEA

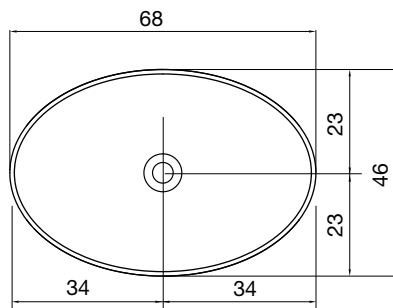
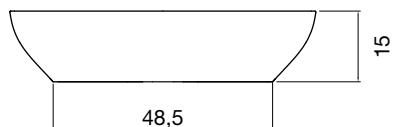
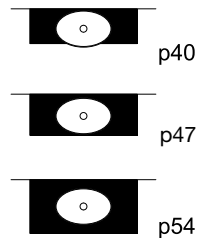

Lavabo ovale sopra piano in Cristalplant biobased completo di piletta con scarico libero e raccordo per sifone.

*Oval top mount biobased Cristalplant sink complete with drain pipe fitting and open plug.*









art. BLOKKO2

art. BLOKKO10



p54

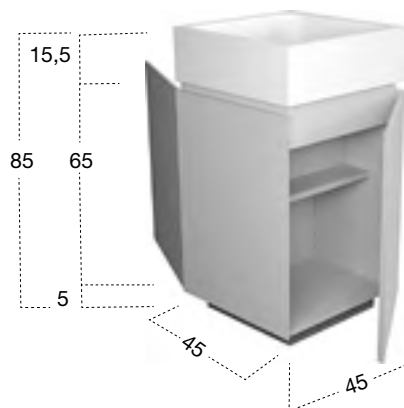
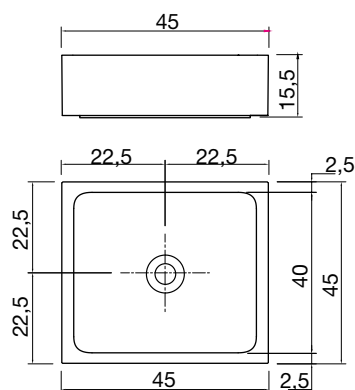
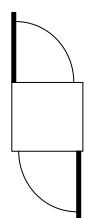

art.  
**BLOKKO2**

Lavabo quadro sopra piano in Cristalplant biobased, completo di piletta con scarico libero e raccordo per sifone.

*Square biobased Cristalplant top mount sink complete with drain pipe fitting and open plug.*

art.  
**BLOKKO10**

Centro stanza con 2 ante, 1 posteriore e 1 anteriore dx o sx e 1 ripiano interno in legno, completo di zoccolo nero goffrato, e lavabo in Cristalplant biobased.

*Freestanding cabinet with 2 doors, front and back right or left and one internal wooden shelf, complete with plinth lacquered embossed black and biobased Cristalplant sink.*



art. BLOKKO

art. BLOKKO11



p54

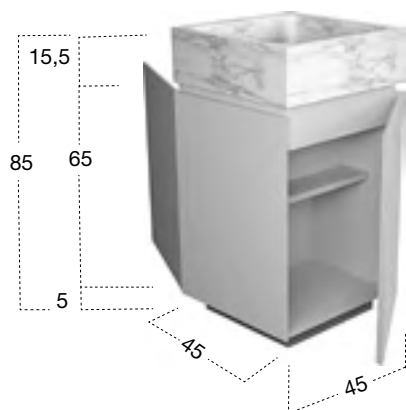
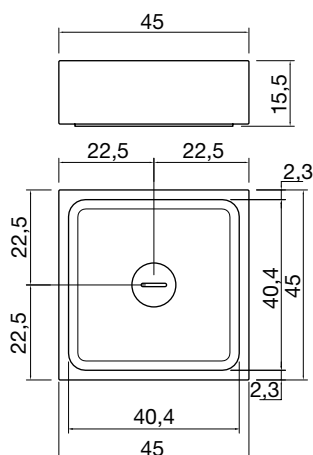
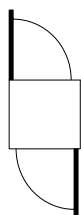

art.  
**BLOKKO**  
Marmo di Carrara

Lavabo quadro sopra piano in pietra, completo di piletta con scarico libero e raccordo per sifone.

*Square top mount stone sink, complete with drain pipe fitting and open plug.*

art.  
**BLOKKO11**

Centro stanza con 2 ante, 1 posteriore e 1 anteriore dx o sx e 1 ripiano interno in legno, completo di zoccolo nero goffrato, e lavabo in Marmo di Carrara.

*Freestanding cabinet with 2 doors, front and back right or left and one internal wooden shelf, complete with plinth lacquered embossed black and Carrara Marble sink.*



art. BULL



p54

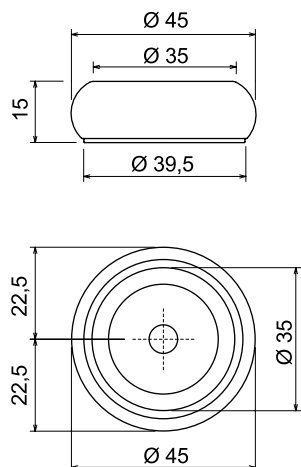

**Pietra Sinai**

Lavabo tondo sopra piano in pietra, completo di piletta con scarico libero e raccordo per sifone.

*Round top mount stone sink complete with drain pipe fitting and open plug.*





Pietra Vesuvio





Pietra Luna

art. PILA11



p54

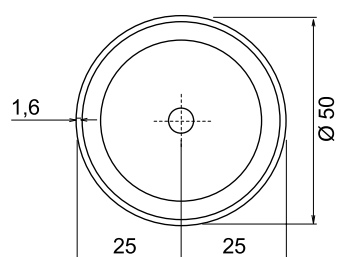
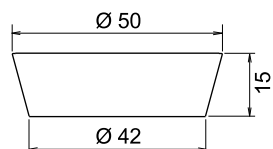

**Pietra Luna / Pietra Vesuvio / Nero Marquina**

Lavabo tondo sopra piano in pietra completo di piletta con scarico libero e raccordo per sifone.

*Round top mount stone sink complete with drain pipe fitting and open plug.*







# SLOT



art. SLOT21

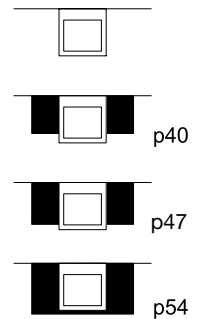
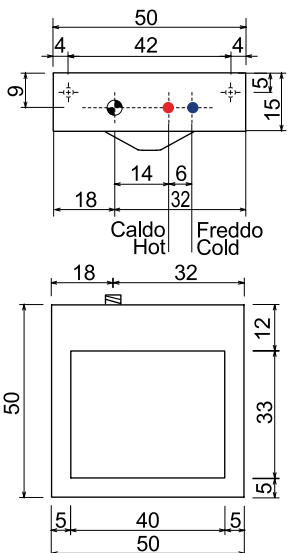

Lavabo quadro sopra piano o da parete in Corian, con sifone incorporato.

Square top or wall mount Corian sink, with incorporated trap.

# SLOT



art. SLOT22

art. SLOT23

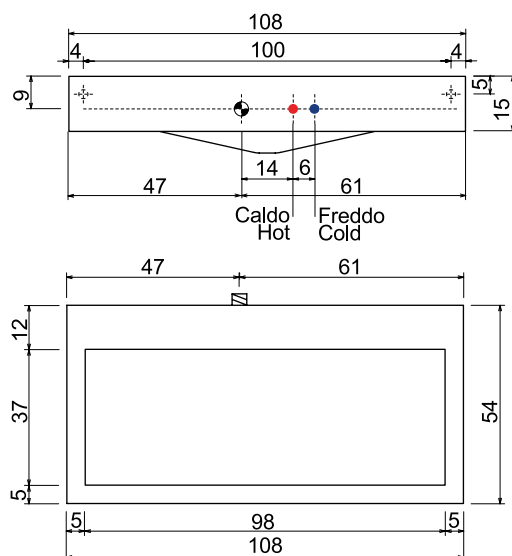
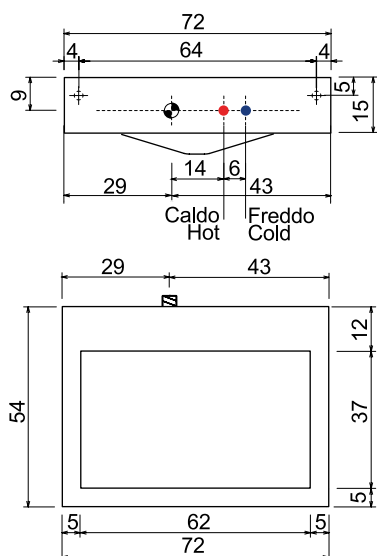

SLOT22

SLOT23

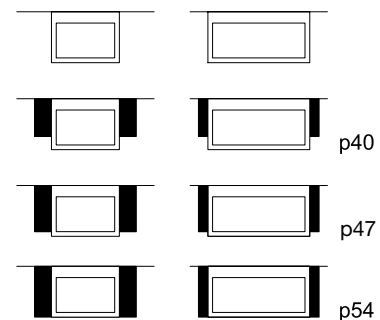

Lavabo rettangolare sopra piano o da parete in Corian, con sifone incorporato.

Rectangular top or wall mount Corian sink, with incorporated trap.







art. BARREL3

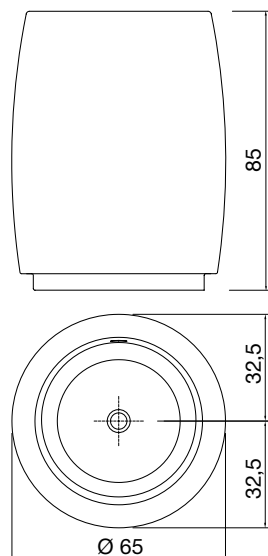

Lavabo da terra in Cristalplant biobased con scarico a pavimento, completo di pileta con scarico a pressione klik-clak, sifone e tubo flessibile.

*Freestanding biobased Cristalplant sink with floor drainage complete with pressure plug, siphon and flexible hose.*









# TUBA



art. TUBA3

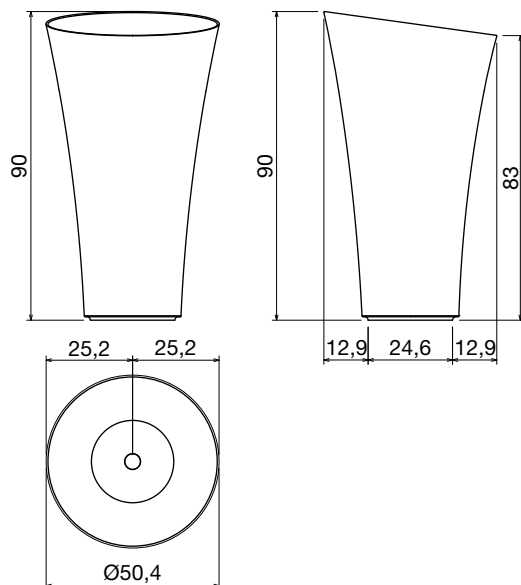

Lavabo da terra in Cristalplant biobased con scarico a pavimento, completo di piletta con scarico libero, sifone e tubo flessibile.  
**N.B.** Su richiesta possibilità di verniciatura esterna.

*Freestanding biobased Cristalplant sink, complete with drain pipe fitting and open plug, trap and flexible hose.  
**P.S.** External lacquering upon request.*





**TENDER** design Carlo Colombo



art. TENDER

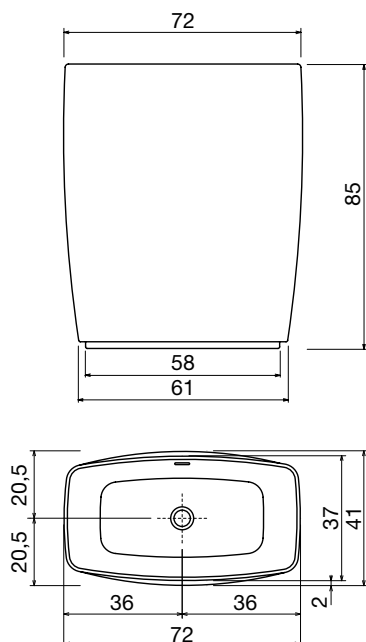

Lavabo da terra in Cristalplant biobased con scarico a pavimento, completo di piletta con scarico a pressione klik-clak, sifone e tubo flessibile.

**N.B.** Su richiesta possibilità di verniciatura esterna.

*Freestanding biobased Cristalplant sink with floor drainage complete with pressure plug, siphon and flexible hose.*

**P.S.** External lacquering upon request.









art. TALAMO3

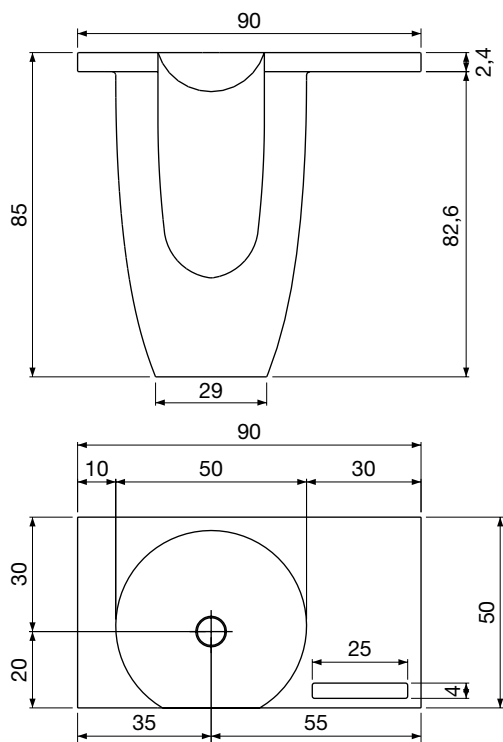

Lavabo da terra in Cristalplant biobased con scarico a pavimento completo di piletta con scarico libero, sifone e tubo flessibile.

Freestanding biobased Cristalplant biobased sink with floor drainage complete with open plug, siphon and flexible hose.







art. KUBIC

art. FOLD

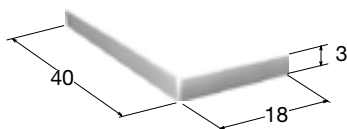
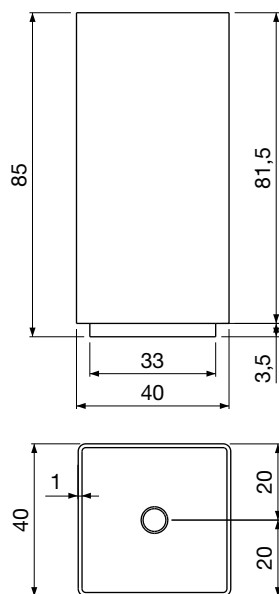

art.  
**KUBIC**

Lavabo quadro da terra in Corian con scarico a pavimento completo di piletta con scarico libero, sifone e tubo flessibile.

*Square freestanding Corian sink with floor drainage complete with open plug, siphon and flexible hose.*

art.  
**FOLDLU**  
**FOLDSA**

Portasalviette in acciaio inox AISI 304.

*Towel holder in satin stainless steel AISI 304.*







art. EGO

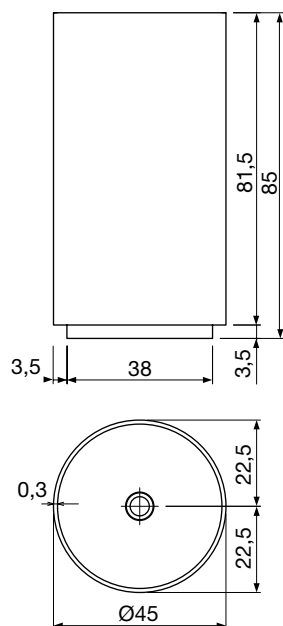

Lavabo cilindrico da terra in Corian con scarico a pavimento completo di piletta con scarico libero, sifone e tubo flessibile.

*Cylindrical freestanding Corian sink with floor drainage complete with drain pipe fitting and open plug, trap and flexible hose.*







art. MR.SPLASH

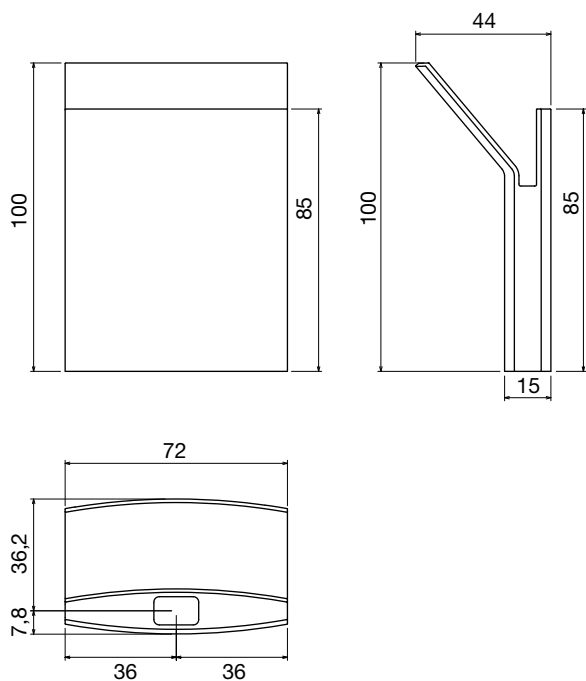

Lavabo da terra in Cristalplant biobased con scarico a pavimento, completo di piletta con scarico libero, sifone e tubo flessibile.

*Freestanding biobased Cristalplant sink with floor drainage complete with open plug, siphon and flexible hose.*







art. BARREL

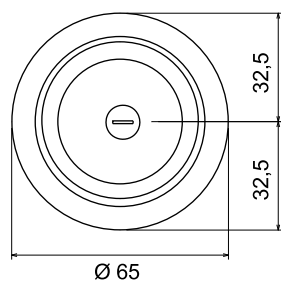
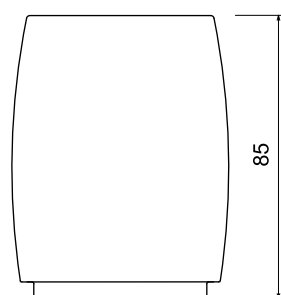

**Pietra Sinai / Nero Marquinia**

Lavabo da terra in pietra con scarico a pavimento, completo di piletta con scarico libero, sifone e tubo flessibile.  
Peso lavabo: 320 kg ca.

*Freestanding stone sink complete with drain pipe fitting and open plug, trap and flexible hose.  
Sink weight: 320 kg approx.*







art. TENDERSG

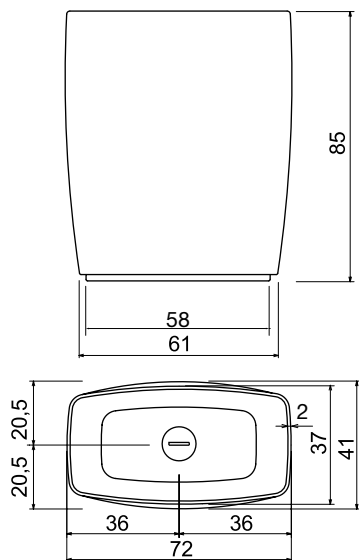

**Pietra Stone Gray**

Lavabo da terra in pietra con scarico a pavimento completo di piletta con scarico libero, sifone e tubo flessibile.  
Peso lavabo: 300 kg.

*Freestanding stone sink complete with drain pipe fitting and open plug, trap and flexible hose.  
Sink weight: 300 kg.*









art. DIERESI

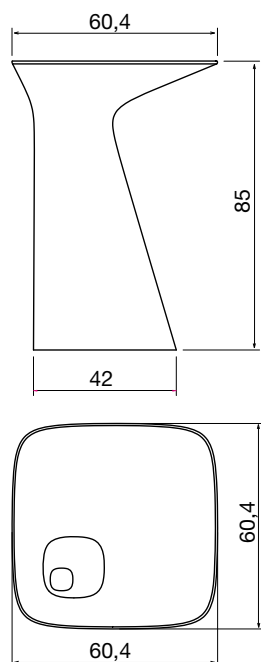

**Marmo di Carrara**

Lavabo da terra in pietra con scarico a pavimento, completo di piletta con scarico libero, sifone e tubo flessibile.  
Peso lavabo: 233 kg.

*Freestanding stone sink with floor drainage complete with open plug, siphon and flexible hose.  
Sink weight: 233 kg.*







art. PIPA

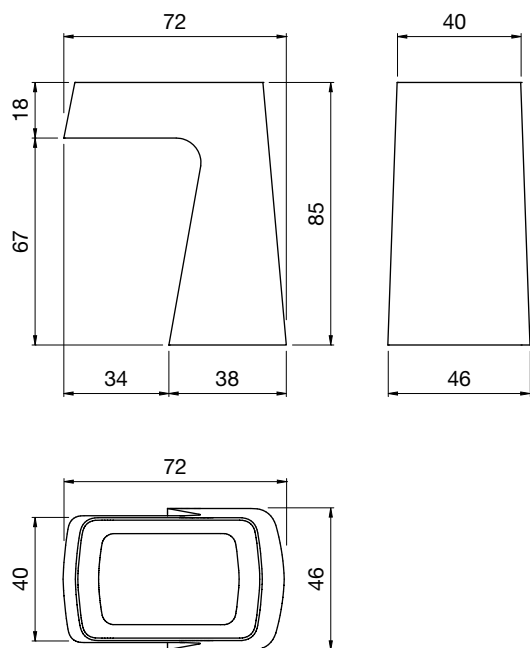

**Marmo di Carrara / Stone Grey**

Lavabo da terra in pietra con scarico a pavimento, completo di piletta con scarico libero, sifone e tubo flessibile.  
Peso lavabo: 233 kg ca.

*Freestanding stone sink complete with drain pipe fitting and open plug, trap and flexible hose.  
Sink weight: 233 kg approx.*







art. TALAMO1

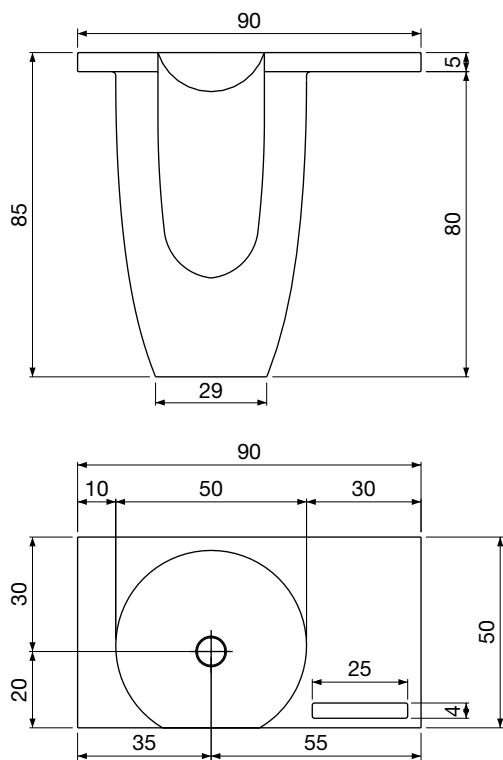

**Pietra Apricena**

Lavabo da terra in pietra con scarico a pavimento, completo di piletta con scarico libero, sifone e tubo flessibile.  
Peso lavabo: 250 kg

*Freestanding stone sink complete with drain pipe fitting and open plug, trap and flexible hose.  
Sink weight: 250 kg*









art. PILA16

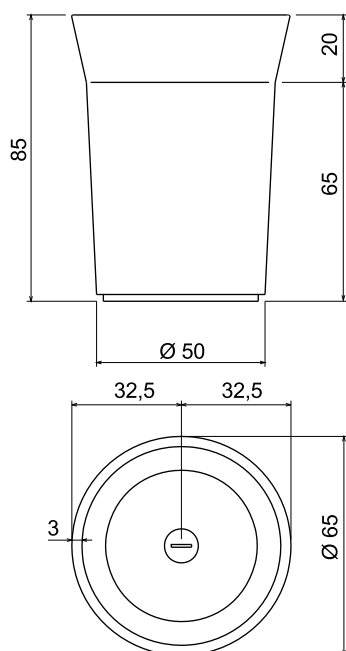

**Pietra Vesuvio**

Lavabo da terra in pietra con scarico a pavimento, completo di piletta con scarico libero, sifone e tubo flessibile.  
Peso lavabo: 240 kg.

*Freestanding stone sink complete with drain pipe fitting and open plug, trap and flexible hose.  
Sink weight: 240 kg.*

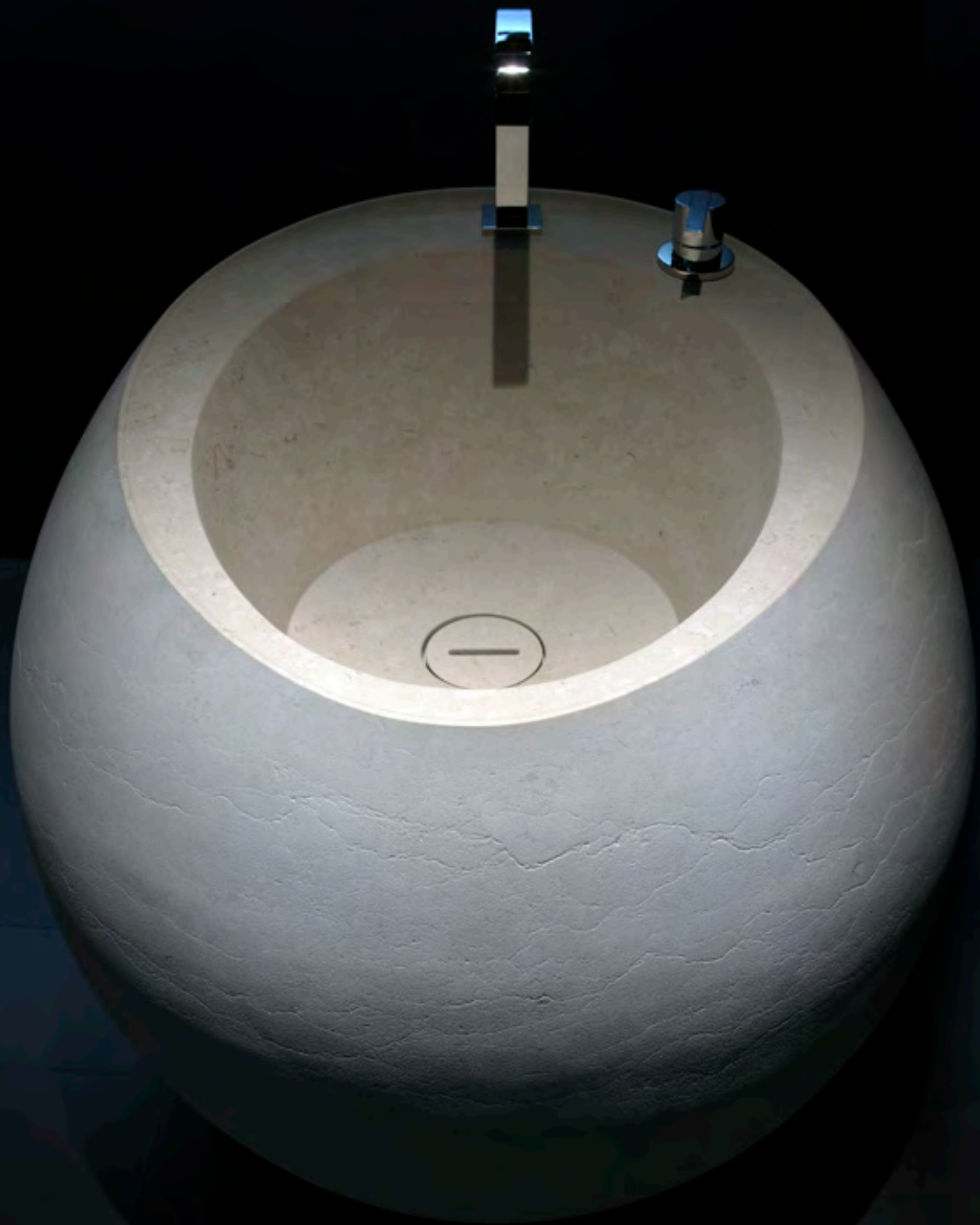



art. OPIUM

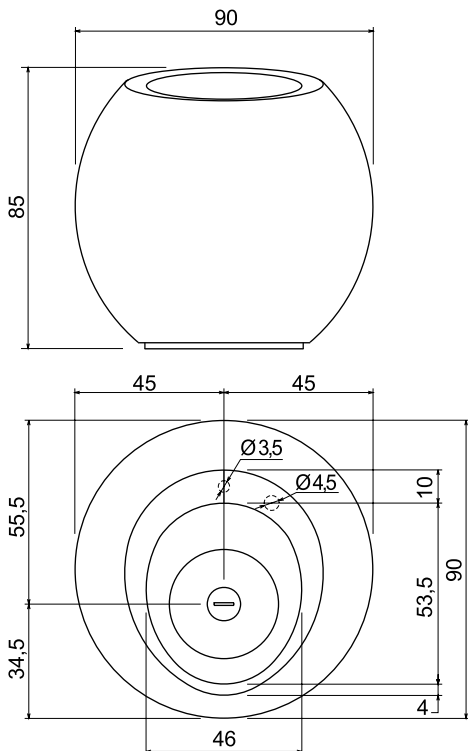

**Pietra Luna**

Lavabo da terra in pietra con scarico a pavimento, completo di piletta con scarico libero, sifone e tubo flessibile.

Peso lavabo: 780 kg.

**N.B.** Per l'ispezione, si consiglia di realizzare un pozzetto esterno (vedere schede tecniche).

*Freestanding stone sink complete with drain pipe fitting and open plug, trap and flexible hose.*

*Sink weight: 780 kg.*

**P.S.** We advise an exterior inspection window (see technical drawings).





**VASCHE / TUBS**









vasche  
tubs

art. **SUITE248** L 192 P 90 H 78 cm / peso vasca tub weight 80 kg / capacità capacity 248 L

art. **SUITE310** L 192 P 90 H 78 cm / peso vasca tub weight 80 kg / capacità capacity 310 L

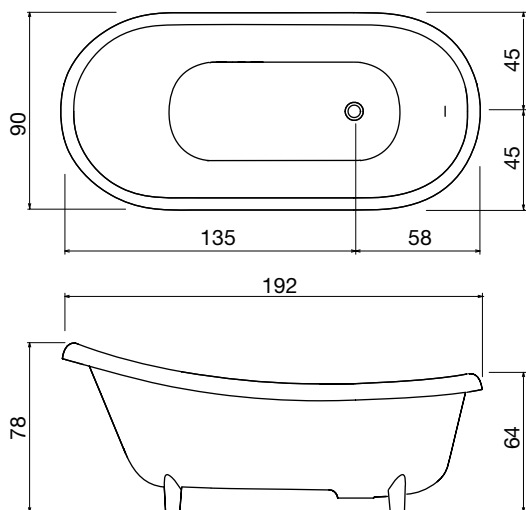

art. **TB933**

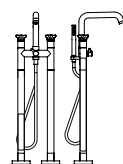

Vasca da bagno ovale in Cristalplant biobased con piedini, completa di piletta con sistema di scarico a pressione klik- clak, sifone e tubo flessibile.

Oval biobased Cristalplant bathtub with feet, complete with drain with pressure plug, siphon and flexible tube.

**EDONIA** design Mario Ferrarini





vasche  
tubs





# EDONIA



vasche  
tubs

art. EDONIA L 172 P 76 H 60 cm / peso vasca tub weight 125 kg / capacità capacity 272 L

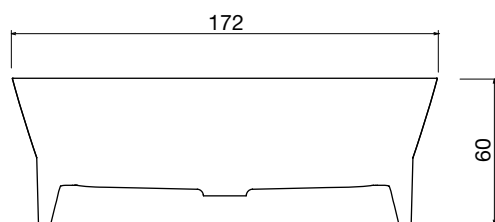
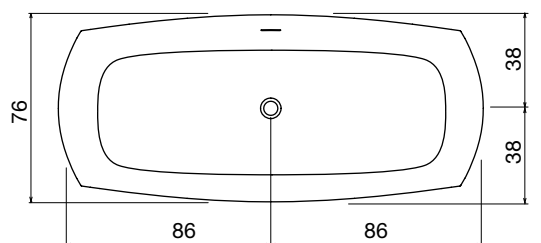

art. TB933

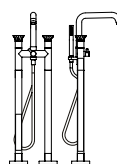

Vasca da bagno rettangolare in Cristalplant biobased con piedini, completa di piletta con sistema di scarico a pressione klik- clak, sifone e tubo flessibile.

*Rectangular biobased Cristalplant bathtub with feet, complete with drain with pressure plug, siphon and flexible tube.*









# WANDA



vasche  
tubs

art. WANDA L 178 P 84 H 77,2 cm / peso vasca tub weight 120 kg / capacità capacity 384 L

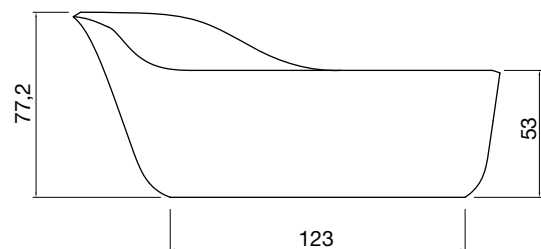
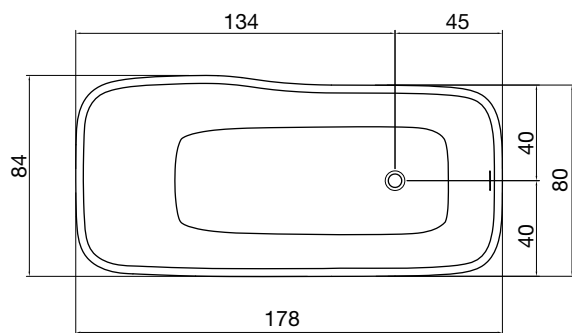

art. AY903LU

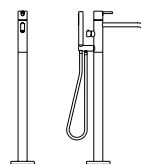

Vasca da bagno ovale in Ceramilux con schienale, completa di piletta con sistema di scarico a pressione klik-clak, sifone e tubo flessibile.

Oval Ceramilux bathtub with back rest complete with drain and pressure plug, siphon and flexible hose.













**art. AGO4** L 175 P 80 H 50 cm / peso vasca tub weight 87 kg / capacità capacity 345 L

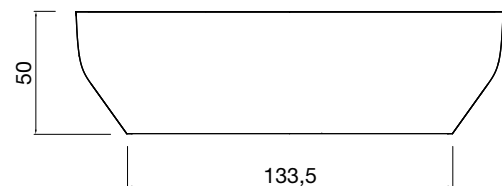
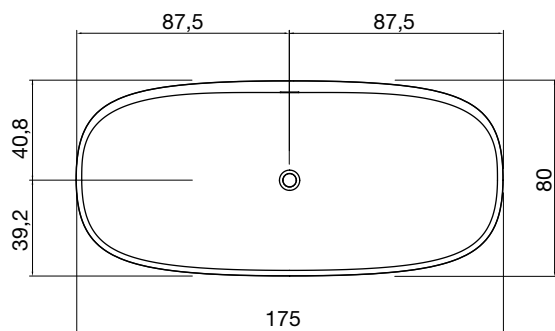

**art. AY903LU**

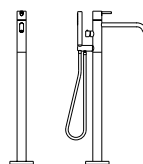

Vasca da bagno ovale in Ceramilux opaco, completa di piletta con sistema di scarico a pressione klik-clak, sifone e tubo flessibile.

*Oval matt Ceramilux bathtub complete with drain and pressure plug, siphon and flexible hose.*

# BAiA

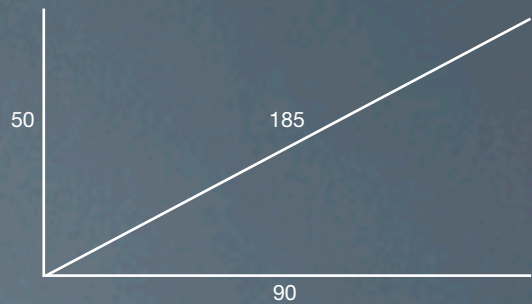

# BAiASMALL



vasche  
tubs









vasche  
tubs

art. **BAiA L** 185 P 90 H 50 cm / peso vasca tub weight 90 kg / capacità capacity 400 L

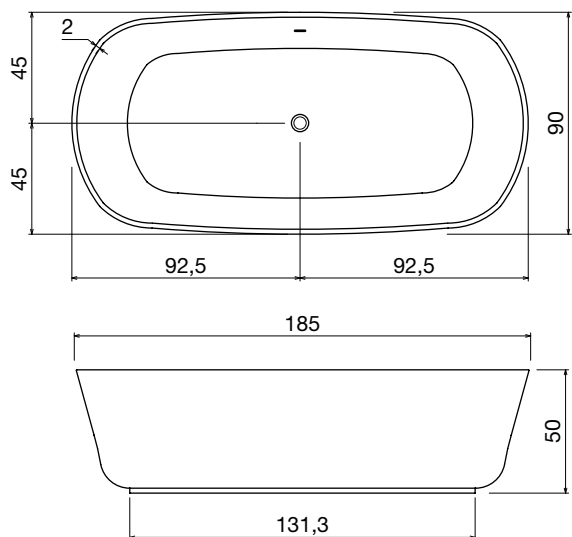

art. **AY903SA**

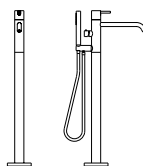

Vasca da bagno ovale in Cristalplant biobased, completa di piletta con sistema di scarico a pressione klik-clak, sifone e tubo flessibile.

*Oval biobased Cristalplant bathtub complete with drain pipe fitting and pressure plug, siphon and flexible hose.*







**BAiA SMALL** design Carlo Colombo



vasche  
tubs

art. **BAiAS L** 170 P 70 H 53 cm / peso vasca tub weight 78 kg / capacità capacity 247 L

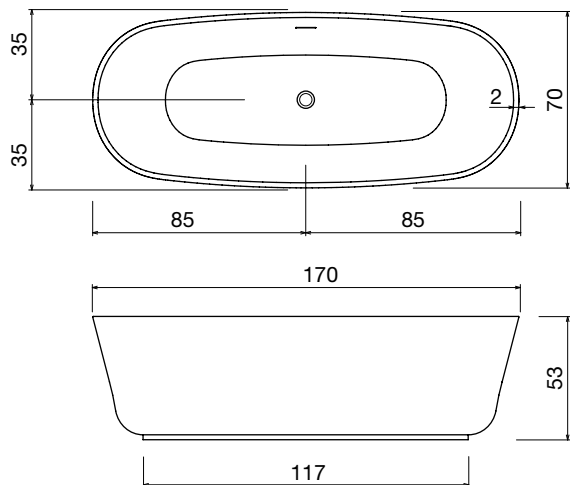

art. **AY903LU**

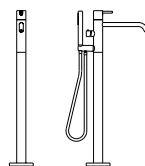

Vasca da bagno ovale in Cristalplant biobased completa di piletta con sistema di scarico a pressione klik-clak, sifone e tubo flessibile.

*Oval biobased Cristalplant bathtub complete with drain pipe fitting and pressure plug, siphon and flexible hose.*

même  
de  
angle  
roit



**BLACK**

**WHITE**

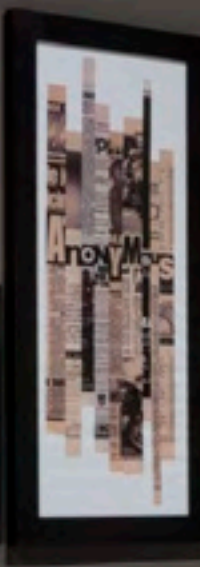



vasche  
tubs

art. **FUNNY WEST** L 151 P 80 H 60 cm / peso vasca *tub weight* 95 kg / capacità *capacity* 292 L

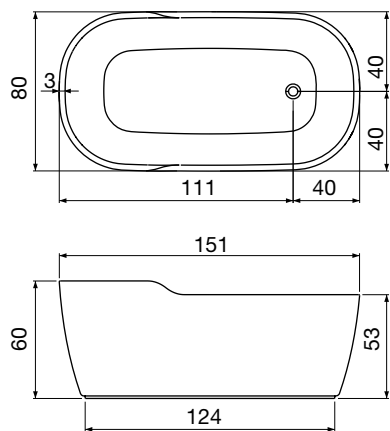

art. **AY903SA**

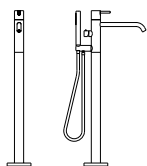

Vasca da bagno ovale con schienale in Cristalplant biobased, completa di piletta con sistema di scarico a pressione klik-clak sifone e tubo flessibile.

*Oval biobased Cristalplant bathtub with back rest complete with drain and pressure plug, siphon and flexible hose.*





poème  
de  
l'angle  
droit

WH



art. **SOLIDEA1** L 190 P 130 H 50 cm / peso vasca tub weight 141 kg / capacità capacity 920 L

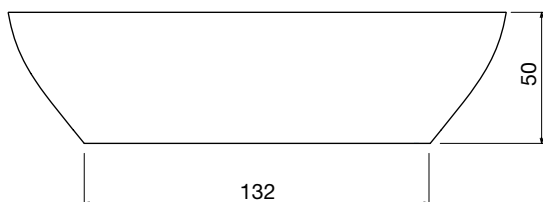
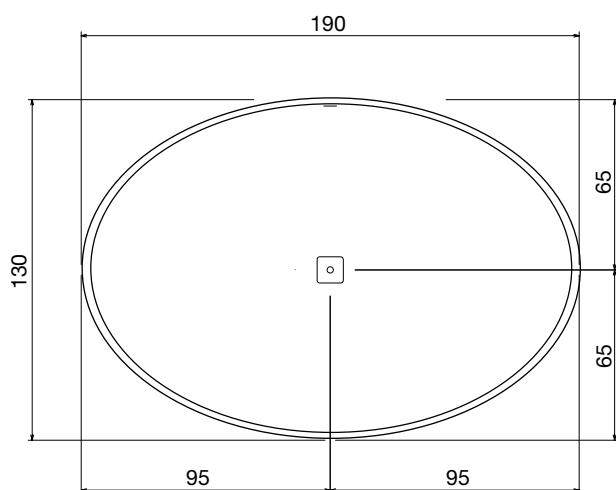

art. **AY903LU**

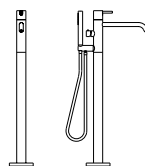

Vasca da bagno ovale in Cristalplant biobased, completa di piletta con sistema di scarico a pressione klik-clak, sifone e tubo flessibile.

*Oval biobased Cristalplant bathtub complete with drain pipe fitting and pressure plug, siphon and flexible hose.*









art. **DUNE1** L 172 P 168 H 64,5 cm / peso vasca tub weight 191 kg / capacità capacity 430 L

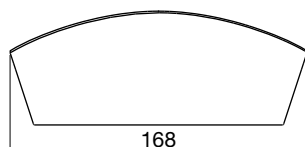
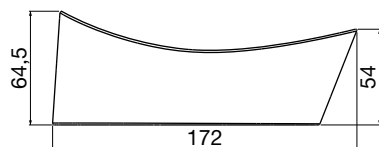
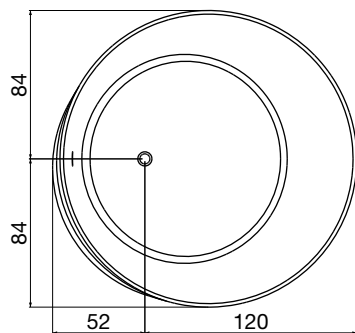

art. **AY903SA**

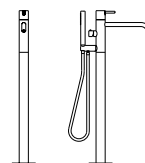

Vasca da bagno tonda in Cristalplant, completa di piletta con sistema di scarico a pressione klik-clak, sifone e tubo flessibile.

Round Cristalplant bathtub complete with drain pipe fitting and pressure plug, siphon and flexible hose.





# DUNE



vasche  
tubs

art. **DUNE2** L 172 P 168 H 64,5 cm / peso vasca tub weight 142 kg / capacità capacity 430 L

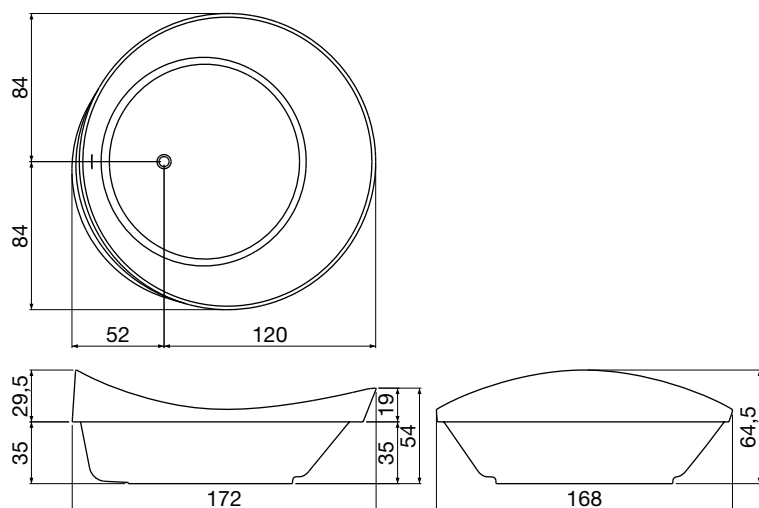

Vasca da bagno tonda a semincasso in Cristalplant, completa di piletta con sistema di scarico a pressione klik-clak, sifone e tubo flessibile.

*Semi-encased round Cristalplant bathtub complete with drain pipe fitting and pressure plug, siphon and flexible hose.*







art. **SARTO15** L 190 P 100 H 50 cm / peso vasca tub weight 130 kg / capacità capacity 290 L

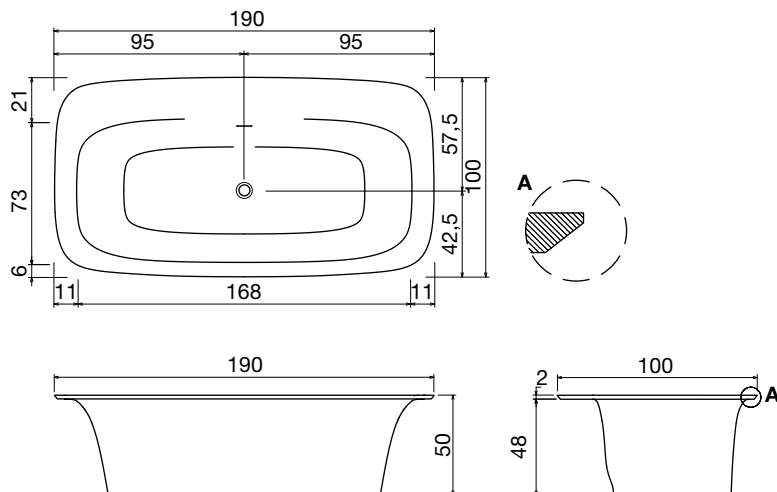

Vasca da bagno ovale freestanding o da incasso in Cristalplant, con bordo per rubinetteria sul retro completa di piletta con scarico a pressione clik-clak, sifone e tubo flessibile.  
**N.B.** Su richiesta possibilità di verniciatura esterna.

*Oval Cristalplant freestanding or encased bathtub with back rim for tap mounting, complete with drain and pressure plug, siphon and flexible hose.*  
**P.S.** External lacquering upon request.



## SARTORIALE



art. SARTO14 L 190 P 100 H 50 cm / peso vasca tub weight 136 kg / capacità capacity 290 L

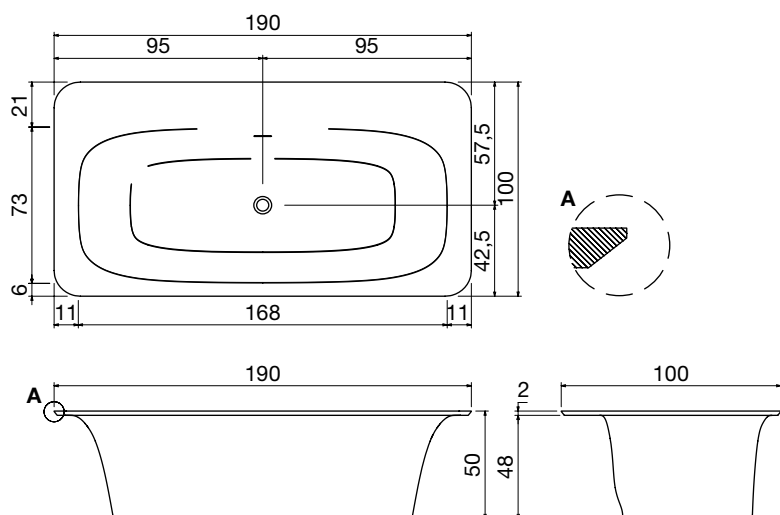

Vasca da bagno rettangolare freestanding o da incasso in Cristalplant con bordo per rubinetteria sul retro e quattro angoli stondati, completa di piletta con scarico a pressione clik-clak, sifone e tubo flessibile.

Rectangular Cristalplant freestanding or encased bathtub with back rim for tap mounting and 4 rounded corners, complete with drain and pressure plug, siphon and flexible hose.



# SARTORIALE



vasche  
tubs

art. SARTO36 L 180 P 100 H 50 cm / peso vasca tub weight 152 kg / capacità capacity 290 L

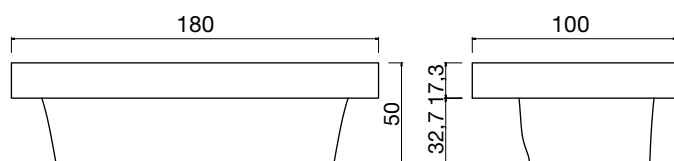
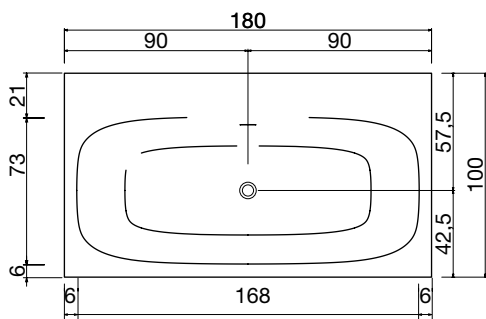

art. BK701



Vasca da bagno rettangolare a semincasso in Cristalplant, con bordo per rubinetteria sul retro, completa di piletta con scarico a pressione klik-clak, sifone e tubo flessibile.

Semi-encased rectangular Cristalplant bathtub with back rim for tap mounting, complete with drain and pressure plug, siphon and flexible hose.

## SARTORIALE



art. SARTO47 L 180 P 85 H 50 cm / peso vasca tub weight 183 kg / capacità capacity 290 L

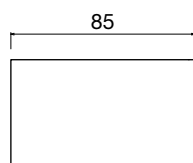
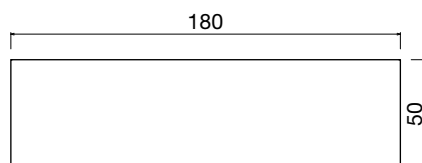
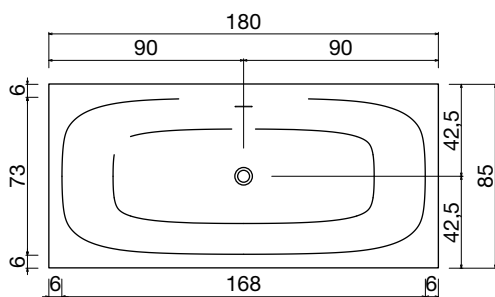

art. BK903N

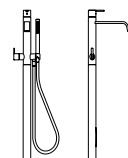

Vasca da bagno rettangolare freestanding in Cristalplant completa di piletta con sistema di scarico a pressione clik-clak, sifone e tubo flessibile.

*Rectangular Cristalplant freestanding bathtub, complete with drain and pressure plug, siphon and flexible hose.*

# SARTORIALE



vasche  
tubs

art. SARTO17 L 190 P 100 H 50 cm / peso vasca tub weight 203 kg / capacità capacity 290 L

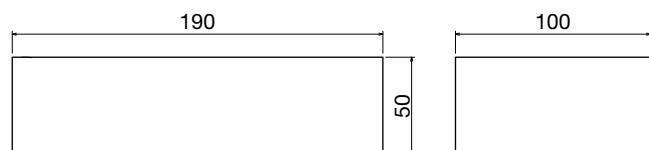
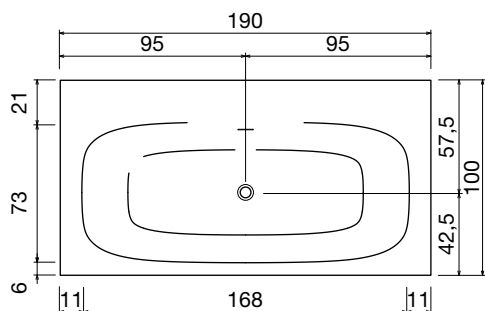

art. BK701



Vasca da bagno rettangolare freestanding in Cristalplant, con bordo per rubinetteria sul retro, completa di piletta con scarico a pressione klik-clak, sifone e tubo flessibile.

Rectangular Cristalplant freestanding bathtub with back rim for tap mounting, complete with drain and pressure plug, siphon and flexible hose.





# SARTORIALE



vasche  
tubs

art. SARTO53 L 180 P 100 H 50 cm / peso vasca tub weight 240 kg / capacità capacity 290 L

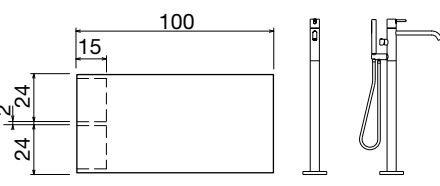
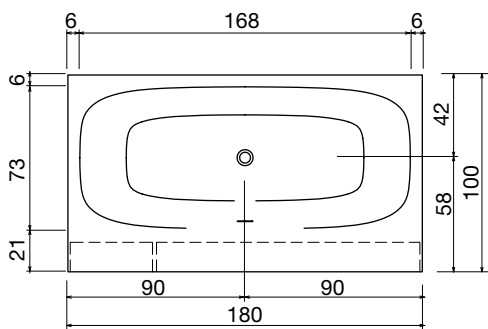

art. AY903SA

Vasca da bagno rettangolare in Cristalplant, con vani a giorno frontali dx o sx, completa di piedini regolabili e piletta con scarico a pressione klik-clak.

*Rectangular Cristalplant bathtub with front, right or left open compartments complete with regulating feet and pressure drain.*





# SARTORIALE



vasche  
tubs

art. SARTO153 L 180 P 100 H 50 cm / peso vasca tub weight 260 kg / capacità capacity 290 L

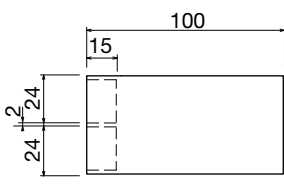
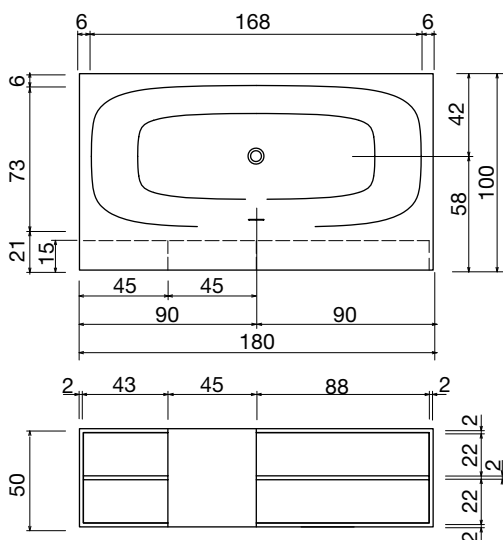

art. BK701

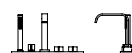

Vasca da bagno rettangolare in Cristalplant con vani a giorno frontali e alloggio per rubinetteria dx o sx, completa di piedini regolabili e piletta con scarico a pressione click-clak.

Rectangular Cristalplant bathtub with front open compartments and right or left tap border complete with regulating feet and pressure drain.





# SARTORIALE



vasche  
tubs

art. SARTO MAXI3 L 197 P 137 H 55 cm / peso vasca tub weight 150 kg / capacità capacity 511 L

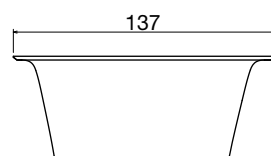
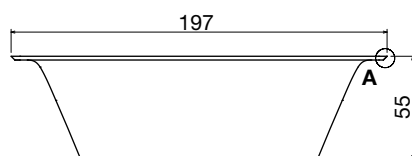
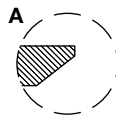
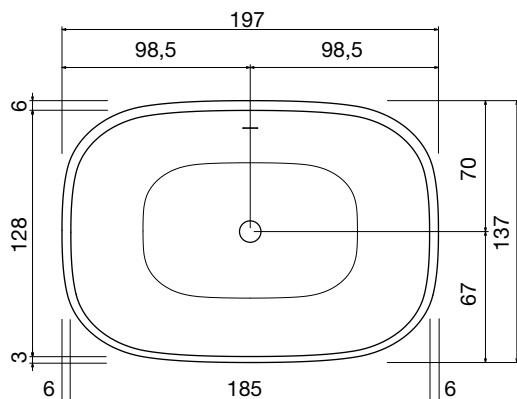

art. AY903SA

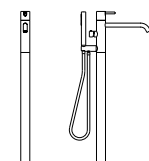

Vasca da bagno rettangolare freestanding o da incasso in Cristalplant, completa di piletta con scarico a pressione klik-clak, sifone e tubo flessibile.

Rectangular Cristalplant freestanding or encased bathtub, complete with drain and pressure plug, siphon and flexible hose.





# SARTORIALE



vasche  
tubs

art. SARTO MAXI2 L 200 P 140 H 55 cm / peso vasca tub weight 157 kg / capacità capacity 511 L

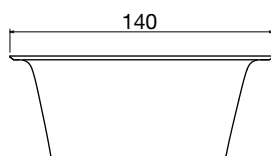
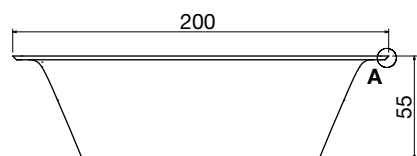
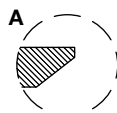
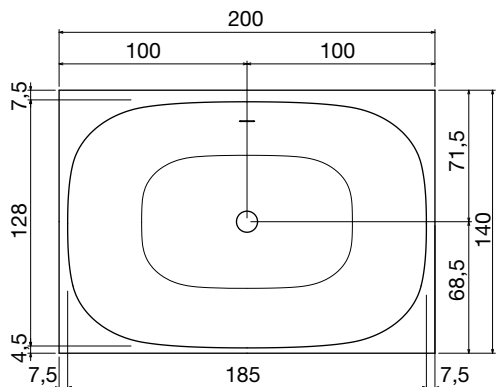

art. BK903N

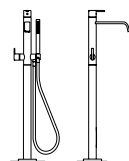

Vasca da bagno rettangolare freestanding o da incasso in Cristalplant completa di piletta con scarico a pressione clik-clak, sifone e tubo flessibile.

*Rectangular Cristalplant freestanding or encased bathtub, complete with drain and pressure plug, siphon and flexible hose.*

# SARTORIALE

art. SARTO15



**SARTO15** H 50 P 100 L 190

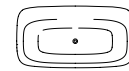
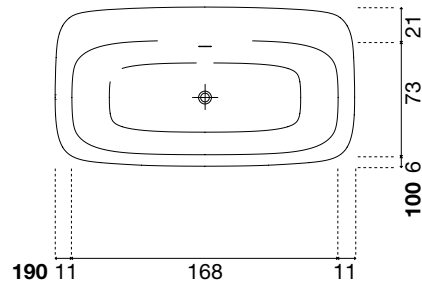

art. SARTO40/20



**SARTO40** H 50 P 85 H L 180  
**SARTO20** H 50 P 85 H L 180

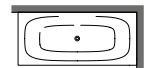
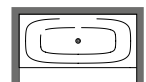
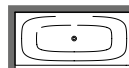
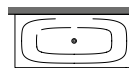
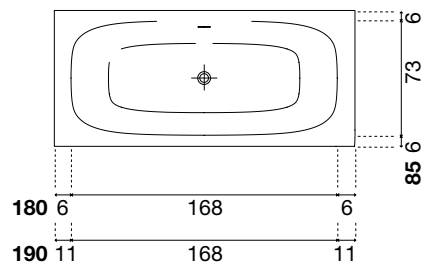

art. SARTO44/24



**SARTO44** H 50 P 85 L 180  
**SARTO24** H 50 P 85 L 190

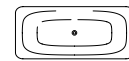
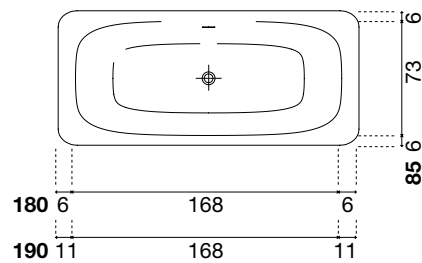

art. SARTO30/10



**SARTO30** H 50 P 100 L 180  
**SARTO10** H 50 P 100 L 190

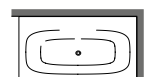
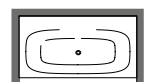
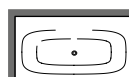
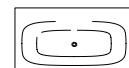
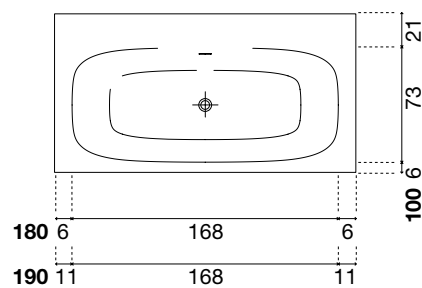



# SARTORIALE

art. SARTO34/14



SARTO34 H 50 P 100 L 180  
SARTO14 H 50 P 100 L 190

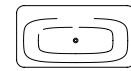
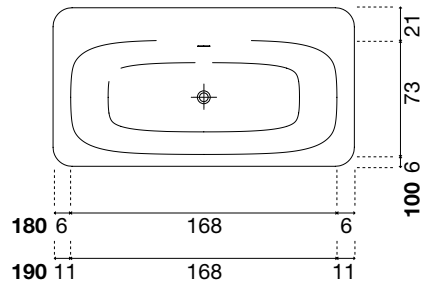

art. SARTO46



SARTO46 H 50 P 85 L 180

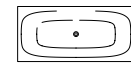
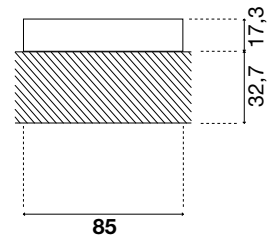
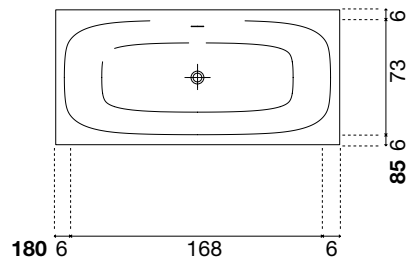

art. SARTO36



SARTO36 H 50 P 100 L 180

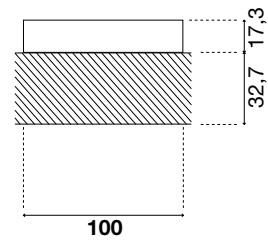
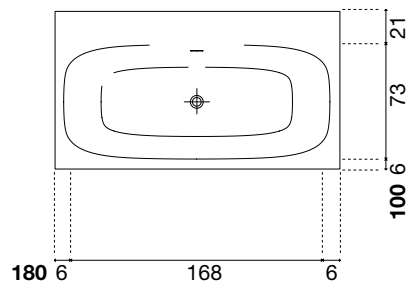

art. SARTO47/27



SARTO47 H 50 P 85 L 180  
SARTO27 H 50 P 85 L 190

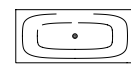
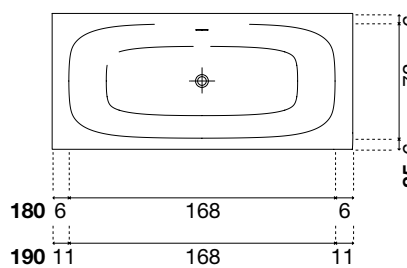

# SARTORIALE

art. SARTO37/17



**SARTO37** H 50 P 100 L 180  
**SARTO17** H 50 P 100 L 190

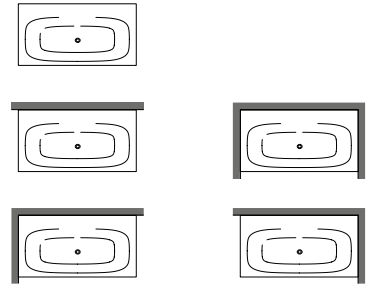
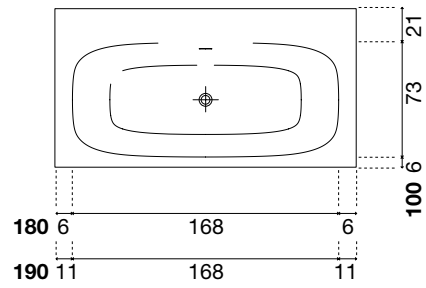

art. SARTO MAXI3



**SARTO MAXI3** H 55 P 137 L 197

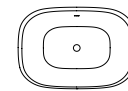
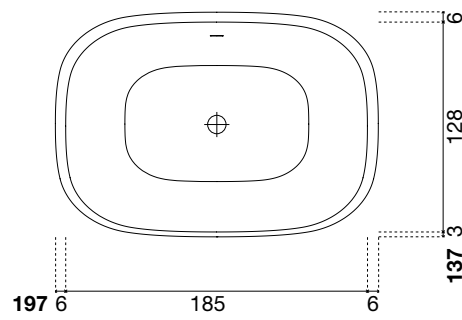

art. SARTO MAXI2



**SARTO MAXI2** H 55 P 140 L 200

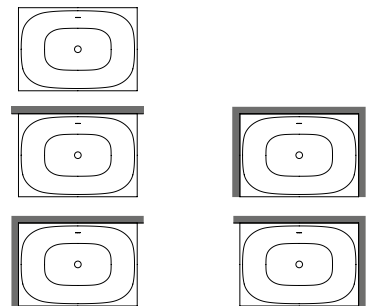
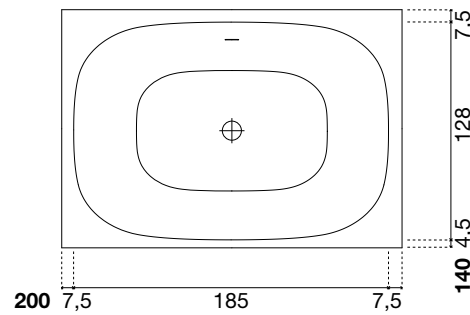

art. SARTO MAXI4



**SARTO MAXI4** H 55 P 140 L 200

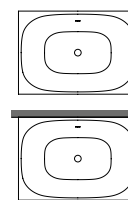
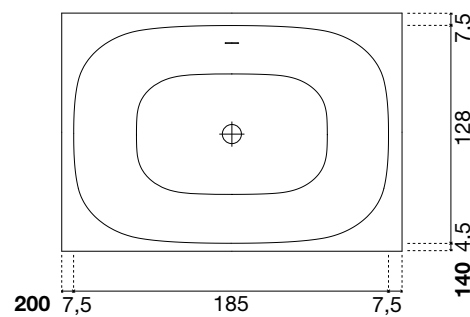

art. SARTO53

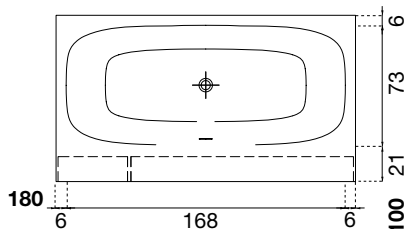

art. SARTO53 H 50 P 100 L 180

art. SARTO153

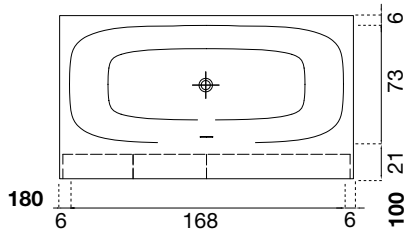

art. SARTO153 L 180 P 100 H 50

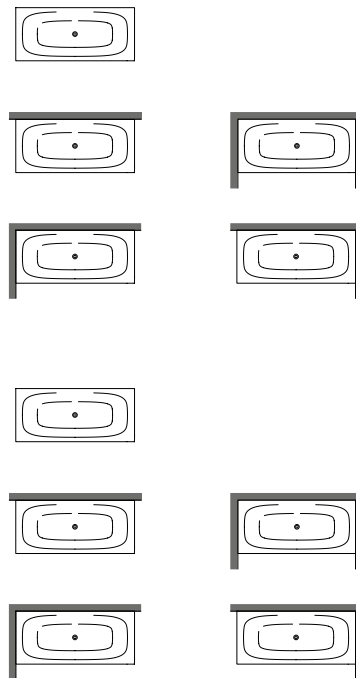

vasche  
tubs

### POSIZIONAMENTO RUBINETTERIA / TAP POSITION

Vista dall'alto e laterale del posizionamento del rubinetto sul bordo da 21 cm lato lungo vasca opzioni A-B degli art. BK701, AY701SA e AY701LU.  
 Top and side view of tap position on border 21 cm. long side options A-B of art. BK701, AY701SA and AY701LU.

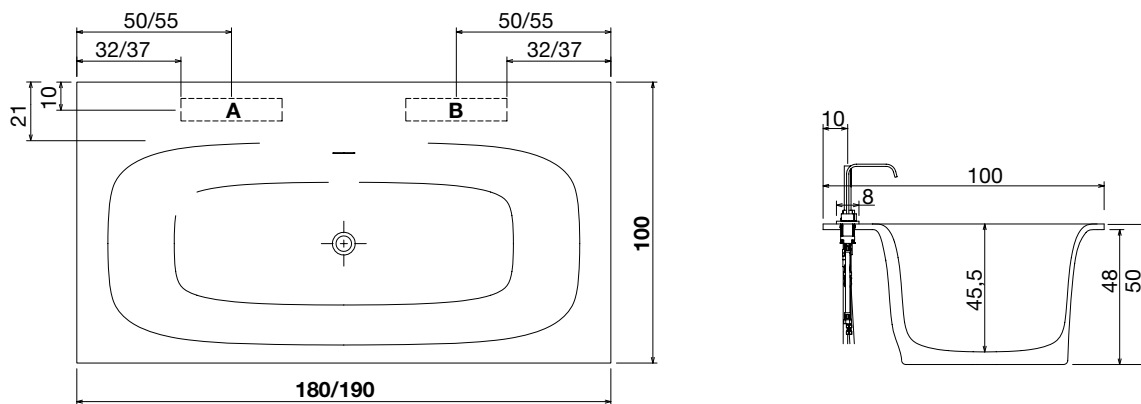

art. BK701

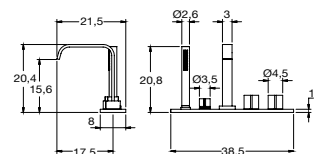

art. AY701SA  
art. AY701LU

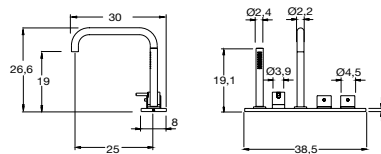

art. BK903N

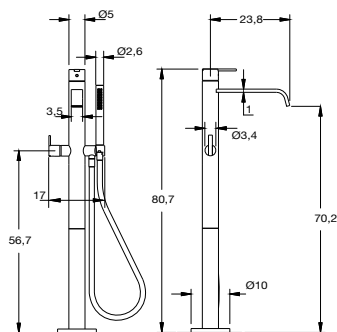

art. AY903SA  
art. AY903LU

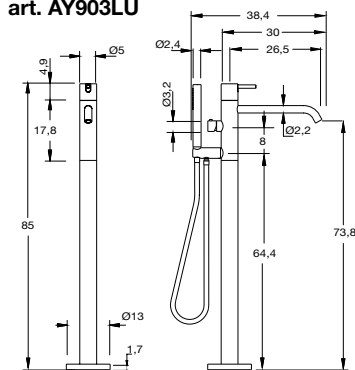

art. TB933

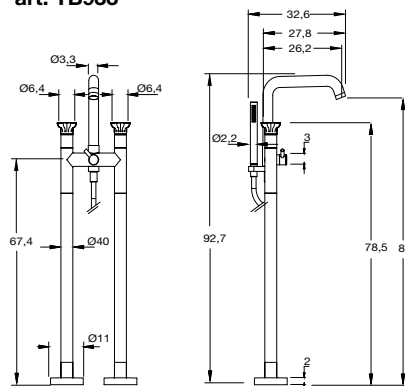





Realizzazione di **vasche a misura** con uno, due, tre lati fuorisquadra; resta invariata la dimensione dell'invaso.

*Production of **bathtubs to measure** with one, two, or three sides unlevelled; the measurements of the tub remain unvaried.*



# BIBLIO



art. **BIBLIO20** L 170 P 80 H 53,5 cm / peso vasca tub weight 75 kg / capacità capacity 288 L  
 art. **BIBLIO21** L 180 P 90 H 53,5 cm / peso vasca tub weight 90 kg / capacità capacity 362 L

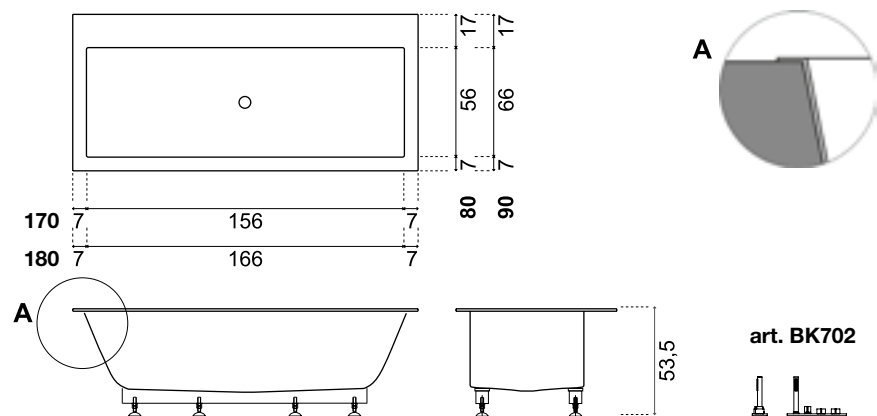

Vasca da bagno rettangolare da incasso in Corian, con bordo per rubinetteria sul retro, completa di piedini regolabili e piletta con scarico a pressione klik-clak.

Encased rectangular Corian bathtub with back rim for tap mounting, complete with regulating feet and drain with pressure plug.

# BIBLIO



art. **BIBLIO10** L 170 P 70 H 53,5 cm / peso vasca *tub weight* 81 kg / capacità *capacity* 288 L  
 art. **BIBLIO11** L 180 P 80 H 53,5 cm / peso vasca *tub weight* 82 kg / capacità *capacity* 362 L

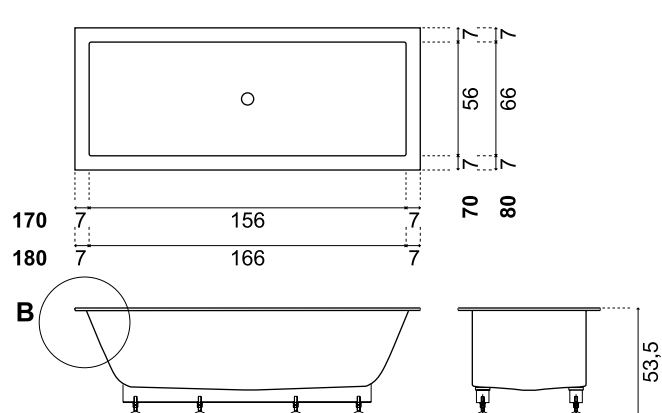

Vasca da bagno rettangolare da incasso in Corian, completa di piedini regolabili e piletta con scarico a pressione klik-clak.

*Encased rectangular Corian bathtub, complete with regulating feet and drain with pressure plug.*



# BIBLIO



vasche  
tubs

art. **BIBLIO30** L 180 P 80 H 53,5 cm / peso vasca tub weight 92 kg / capacità capacity 288 L  
 art. **BIBLIO31** L 190 P 90 H 53,5 cm / peso vasca tub weight 95 kg / capacità capacity 362 L

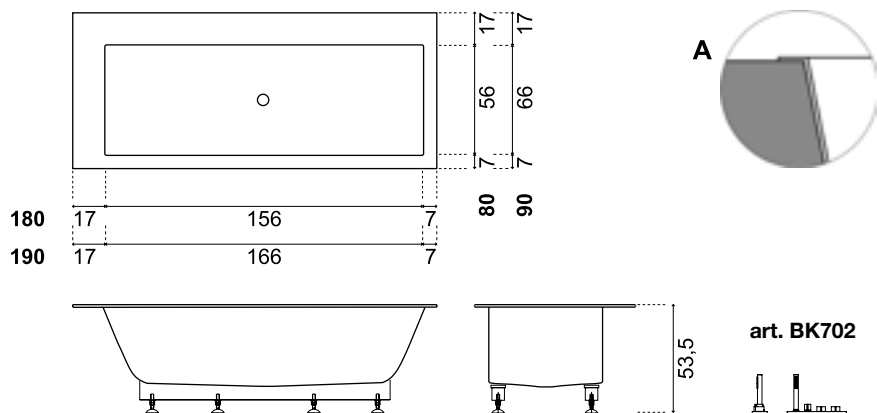

Vasca da bagno rettangolare da incasso in Corian, con bordo per rubinetteria sul retro e laterale dx o sx, completa di piedini regolabili e piletta con scarico a pressione klik-clak.

*Encased rectangular Corian bathtub with back and right or left side rim for tap mounting, complete with regulating feet and drain with pressure plug.*



# BIBLIO



vasche  
tubs

art. **BIBLIO80** L 180 P 80 H 53,5 cm / peso vasca tub weight 105 kg / capacità capacity 288 L  
 art. **BIBLIO81** L 190 P 90 H 53,5 cm / peso vasca tub weight 121 kg / capacità capacity 362 L

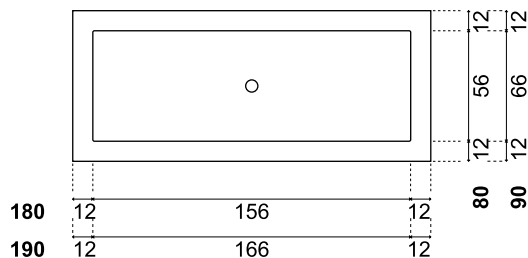

art. **BRIDGE**

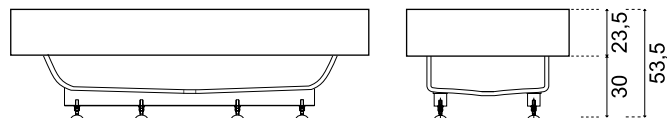
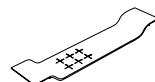

art. **BK702**



Vasca da bagno rettangolare a incasso in Corian, completa di piedini regolabili e piletta con scarico a pressione clik-clak.

*Encased rectangular Corian bathtub, complete with regulating feet and drain with pressure plug.*





# BIBLIO



vasche  
tubs

art. **BIBLIO70** L 180 P 80 H 53,5 cm / peso vasca tub weight 118 kg / capacità capacity 288 L  
 art. **BIBLIO71** L 190 P 90 H 53,5 cm / peso vasca tub weight 131 kg / capacità capacity 362 L

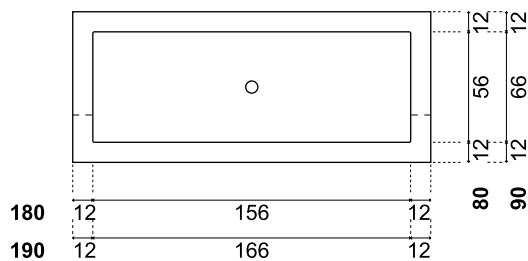

art. **BRIDGE**

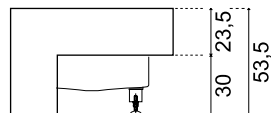

art. **BK701**



Vasca da bagno rettangolare a semincasso frontale in Corian, completa di piedini regolabili e piletta con scarico a pressione klik-clak.

*Semi-encased rectangular Corian bathtub complete with regulating feet and drain with pressure plug.*







# BIBLIO

vasche  
tubs



art. **BIBLIO62** L 180 P 90 H 53,5 cm / peso vasca tub weight 158 kg / capacità capacity 288 L  
 art. **BIBLIO63** L 190 P 100 H 53,5 cm / peso vasca tub weight 167 kg / capacità capacity 362 L

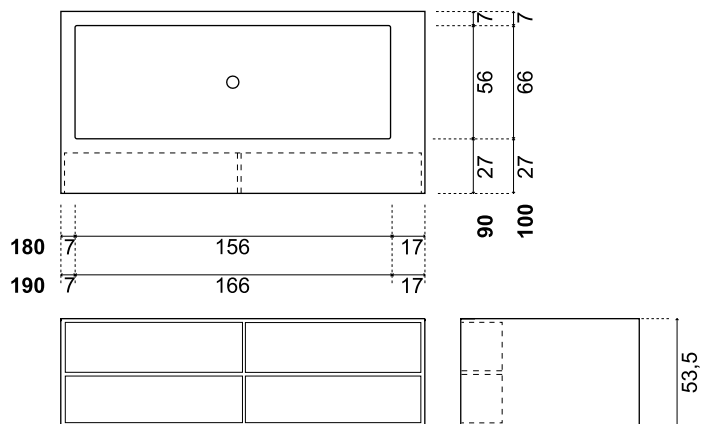

Vasca da bagno rettangolare in Corian con vani a giorno frontali e bordo per rubinetteria laterale dx o sx, completa di piedini regolabili e piletta con scarico a pressione klik-clak.

*Rectangular Corian bathtub with front open shelves and right or left side rim for tap mounting, complete with regulating feet and drain with pressure plug.*



# BIBLIO



vasche  
tubs

art. **BIBLIO52** L 170 P 90 H 53,5 cm / peso vasca tub weight 128 kg / capacità capacity 288 L  
 art. **BIBLIO53** L 180 P 100 H 53,5 cm / peso vasca tub weight 133 kg / capacità capacity 362 L

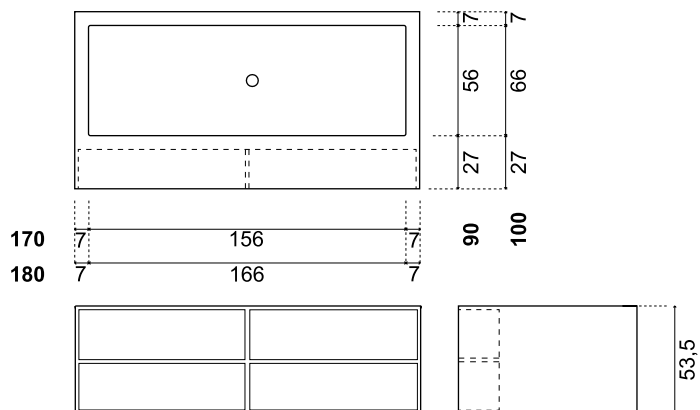

art. **BK903N**

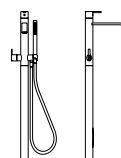

Vasca da bagno rettangolare in Corian, con vani a giorno frontali, completa di piedini regolabili e piletta con scarico a pressione klik-clak.

*Rectangular Corian bathtub with front open shelves, complete with regulating feet and drain with pressure plug.*





# BIBLIO

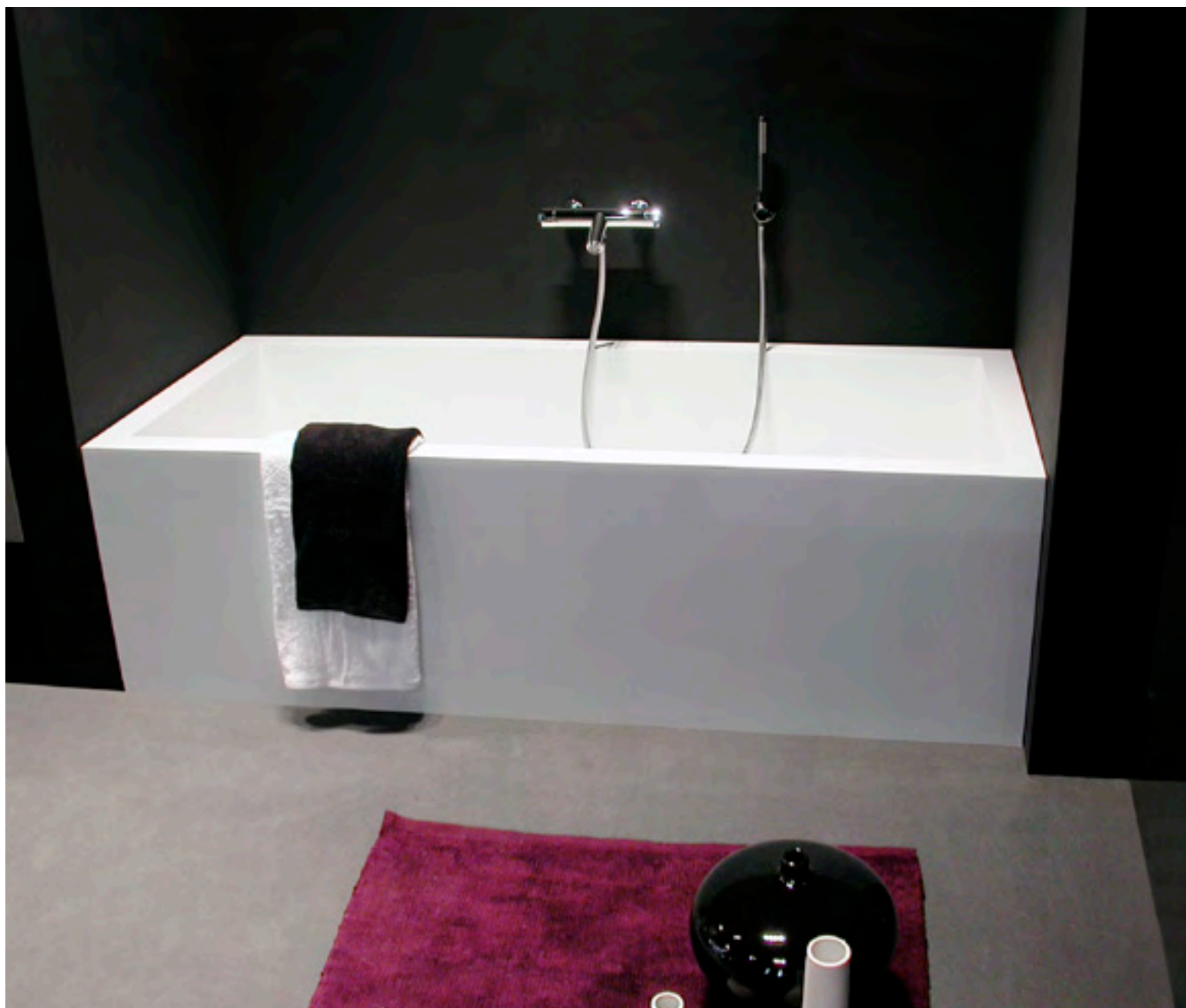

vasche  
tubs

art. **BIBLIO12** L 170 P 70 H 53,5 cm / peso vasca tub weight 101 kg / capacità capacity 288 L  
 art. **BIBLIO13** L 180 P 80 H 53,5 cm / peso vasca tub weight 142 kg / capacità capacity 362 L

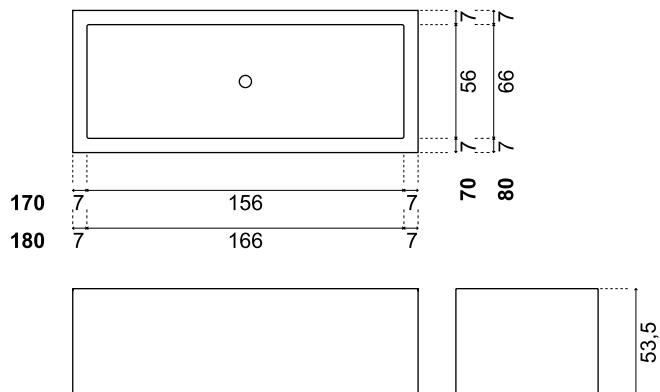

Vasca da bagno rettangolare in Corian, completa di piedini regolabili e piletta con scarico a pressione clik-clak.

Rectangular Corian bathtub, complete with regulating feet and drain with pressure plug.





# BIBLIO



vasche  
tubs

art. **BIBLIO22** L 170 P 80 H 53,5 cm / peso vasca tub weight 152 kg / capacità capacity 288 L  
 art. **BIBLIO23** L 180 P 90 H 53,5 cm / peso vasca tub weight 160 kg / capacità capacity 362 L

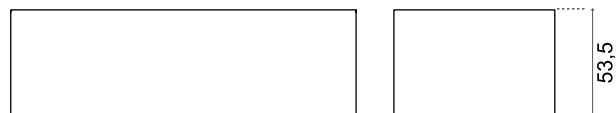
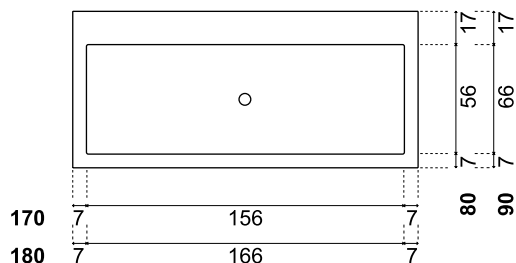

art. **BRIDGE**



art. **BK702**

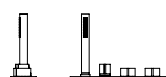

Vasca da bagno rettangolare in Corian, con bordo per rubinetteria sul retro, completa di piedini regolabili e piletta con scarico a pressione klik-clak.

*Rectangular Corian bathtub with back rim for tap mounting, complete with regulating feet and drain with pressure plug.*





# BIBLIO



vasche  
tubs

art. **BIBLIO64** L 180 P 90 H 53,5 cm / peso vasca tub weight 122 kg / capacità capacity 288 L  
 art. **BIBLIO65** L 190 P 100 H 53,5 cm / peso vasca tub weight 133 kg / capacità capacity 362 L

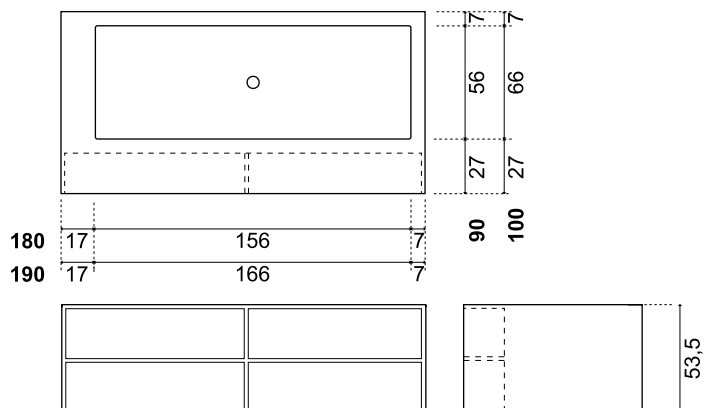

art. **BK702**



Vasca da bagno rettangolare in Corian, con vani a giorno frontali e bordo per rubinetteria dx o sx, rivestita su 4 lati con pannelli in multistrato impiallacciati in essenza di legno, completa di piedini regolabili e piletta con scarico a pressione clik-clak.

*Rectangular Corian bathtub with front open shelves and right or left side rim for tap mounting, covered on 4 sides with plywood panels veneered with wood essence complete with regulating feet and drain with pressure plug.*



# BIBLIO



art. **BIBLIO42** L 190 P 80 H 53,5 cm / peso vasca *tub weight* 129 kg / capacità *capacity* 288 L  
 art. **BIBLIO43** L 200 P 90 H 53,5 cm / peso vasca *tub weight* 138 kg / capacità *capacity* 362 L

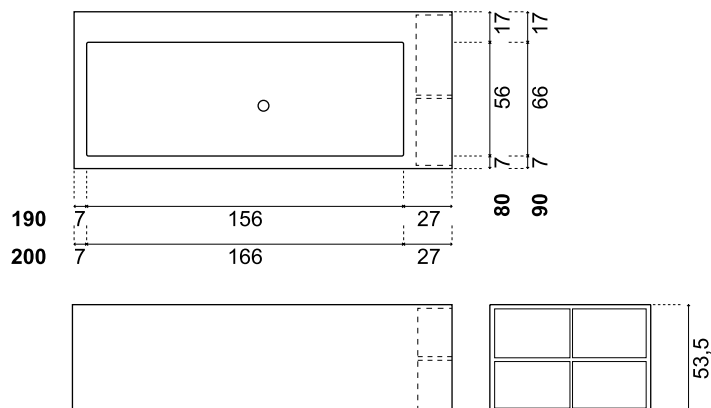

art. **BK903N**

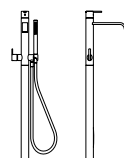

Vasca da bagno rettangolare in Corian, con bordo per rubinetteria sul retro e vani a giorno laterali dx o sx, completa di piedini regolabili e piletta con scarico a pressione klik-clak.

*Rectangular Corian bathtub with back rim for tap mounting and right or left side open shelves, complete with regulating feet and drain with pressure plug.*

# BIBLIO



vasche  
tubs

art. **BIBLIO44** L 190 P 80 H 53,5 cm / peso vasca tub weight 135 kg / capacità capacity 288 L  
 art. **BIBLIO45** L 200 P 90 H 53,5 cm / peso vasca tub weight 152 kg / capacità capacity 362 L

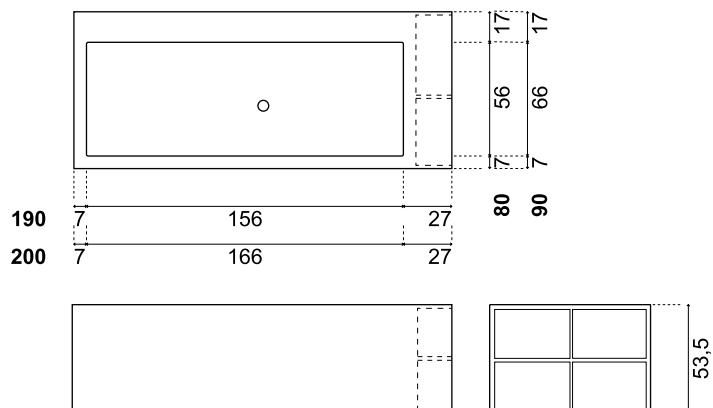

art. **BRIDGE**

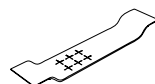

Vasca da bagno rettangolare in Corian, con bordo per rubinetteria sul retro e vani a giorno laterali dx o sx, rivestita su 4 lati con pannelli in multistrato impiallacciati in essenza di legno, completa di piedini regolabili e piletta con scarico a pressione clik-clak.

art. **BK702**



Rectangular Corian bathtub with back rim for tap mounting and right or left side open shelves, covered on 4 sides with plywood panels veneered with wood essence complete with regulating feet and drain with pressure plug.







# BIBLIO



vasche  
tubs

art. **BIBLIO103** L 200 P 100 H 53,5 cm / peso vasca tub weight 121 kg / capacità capacity 362 L

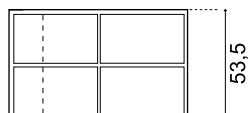
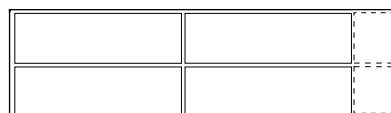
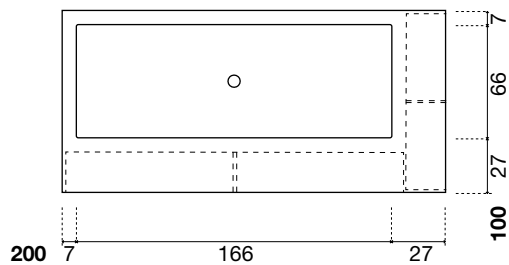

art. **AY903LU**

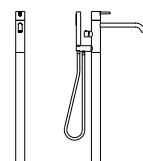

Vasca da bagno rettangolare in Corian con vani a giorno frontali e laterali, completa di piedini regolabili e piletta con scarico a pressione clik-clak.

*Rectangular Corian bathtub with front and lateral open shelves, complete with regulating feet and drain with pressure plug.*



# BIBLIO



vasche  
tubs

art. **BIBLIOXL** L 186 P 160 H 53,5 cm / peso vasca *tub weight* 153 kg / capacità *capacity* 767 L

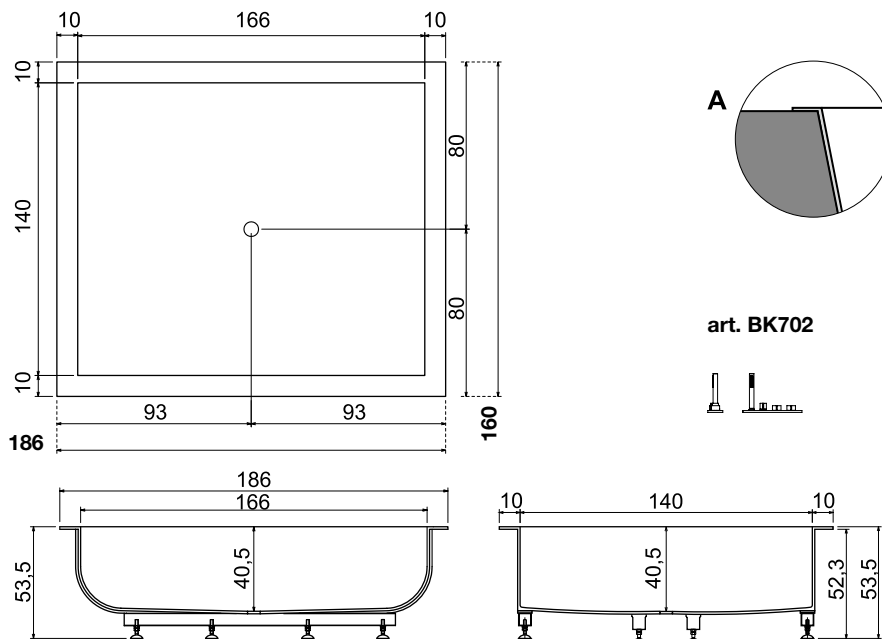

Vasca da bagno rettangolare da incasso in Corian, completa di piedini regolabili e piletta con scarico a pressione klik-clak.

*Encased rectangular Corian bathtub, complete with regulating feet and drain with pressure plug.*



# BIBLIO

art. BIBLIO10/11/12/13/14/15

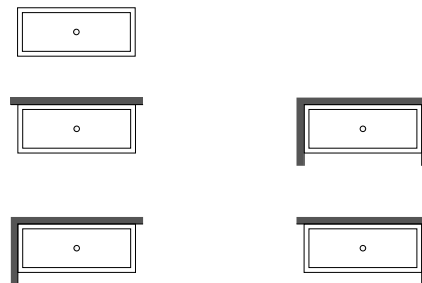
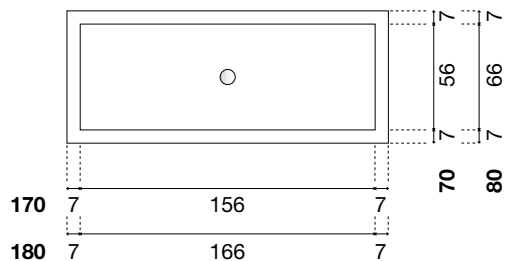

**BIBLIO10** H 53,5 P 70 L 170 cm  
**BIBLIO11** H 53,5 P 80 L 180 cm

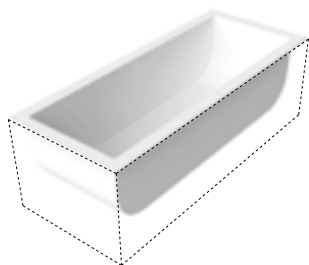

**BIBLIO12** H 53,5 P 70 L 170 cm  
**BIBLIO13** H 53,5 P 70 L 180 cm

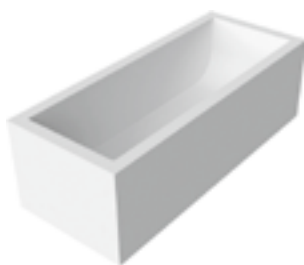

**BIBLIO14** H 53,5 P 70 L 170 cm  
**BIBLIO15** H 53,5 P 80 L 180 cm

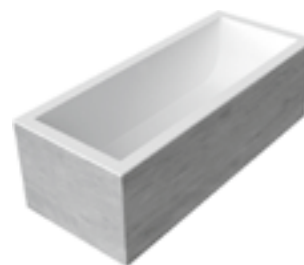

art. BIBLIO20/21/22/23/24/25

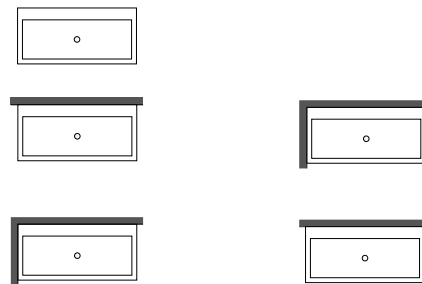
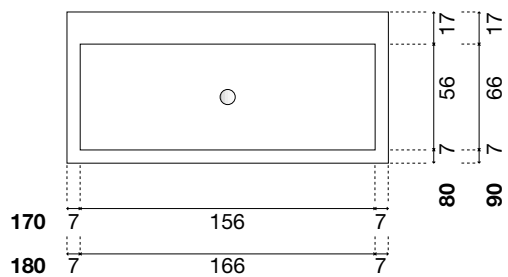

**BIBLIO20** H 53,5 P 80 L 170 cm  
**BIBLIO21** H 53,5 P 90 L 180 cm

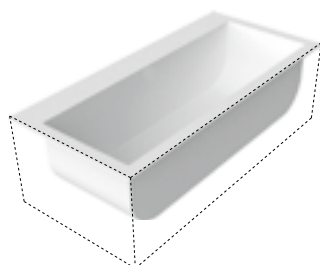

**BIBLIO22** H 53,5 P 80 L 170 cm  
**BIBLIO23** H 53,5 P 90 L 180 cm

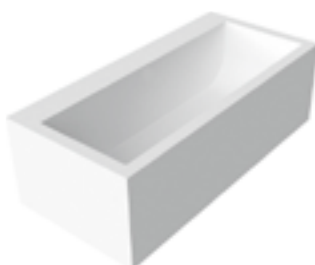

**BIBLIO24** H 53,5 P 80 L 170 cm  
**BIBLIO25** H 53,5 P 90 L 180 cm

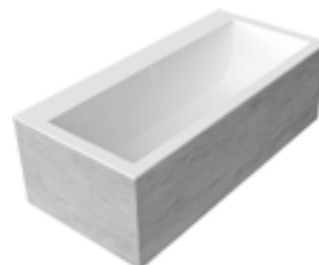

# BIBLIO

art. BIBLIO30/31/32/33/34/35

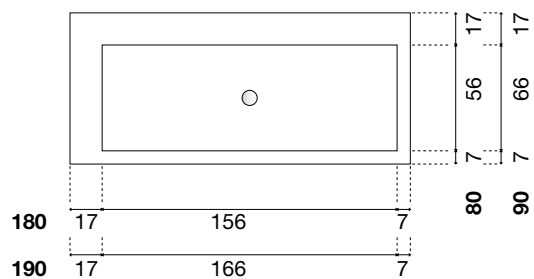

**BIBLIO30** H 53,5 P 80 L 180 cm  
**BIBLIO31** H 53,5 P 90 L 190 cm

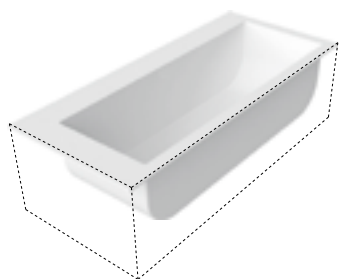

**BIBLIO32** H 53,5 P 80 L 180 cm  
**BIBLIO33** H 53,5 P 90 L 190 cm

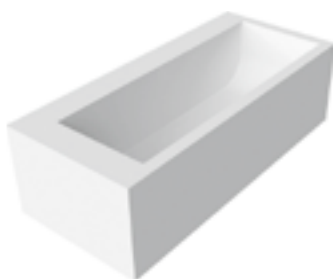

**BIBLIO34** H 53,5 P 80 L 180 cm  
**BIBLIO35** H 53,5 P 90 L 190 cm

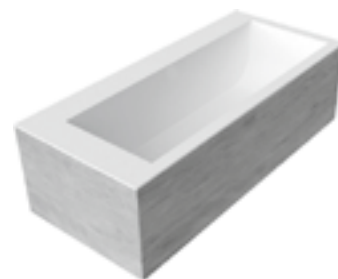

vasche  
tubs

art. BIBLIO42/43/44/45

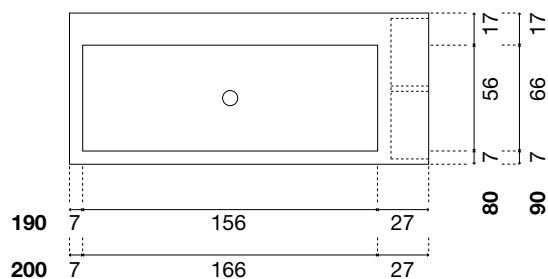

**BIBLIO42** H 53,5 P 80 L 190 cm  
**BIBLIO43** H 53,5 P 90 L 200 cm

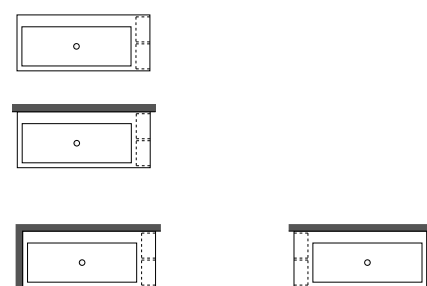
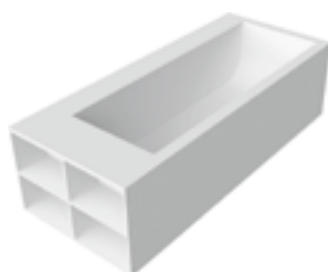

**BIBLIO44** H 53,5 P 80 L 190 cm  
**BIBLIO45** H 53,5 P 90 L 200 cm

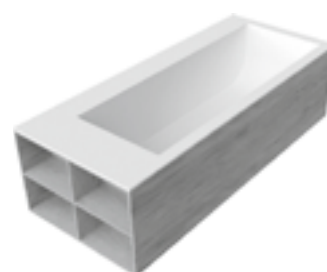

# BIBLIO

art. BIBLIO52/53/54/55

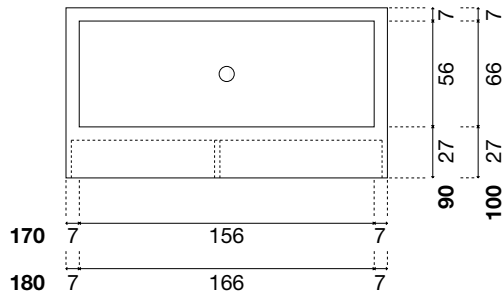

**BIBLIO52** H 53,5 P 90 L 170 cm  
**BIBLIO53** H 53,5 P 100 L 180 cm

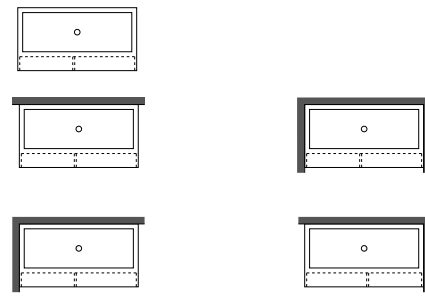

**BIBLIO54** H 53,5 P 90 L 170 cm  
**BIBLIO55** H 53,5 P 100 L 180 cm

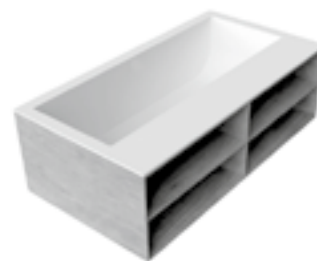

art. BIBLIO60/61/62/63/64/65

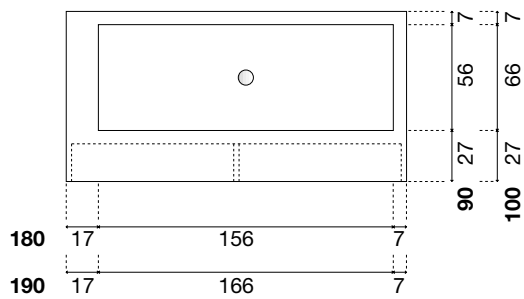

**BIBLIO60** H 53,5 P 90 L 180 cm  
**BIBLIO61** H 53,5 P 100 L 190 cm

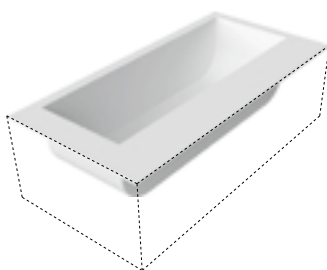

**BIBLIO62** H 53,5 P 90 L 180 cm  
**BIBLIO63** H 53,5 P 100 L 190 cm

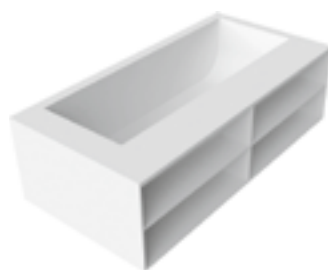

**BIBLIO64** H 53,5 P 90 L 180 cm  
**BIBLIO65** H 53,5 P 100 L 190 cm

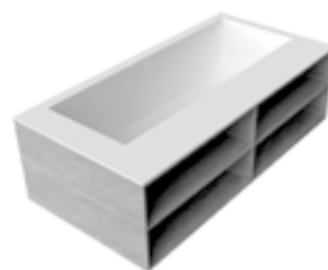



# BIBLIO

art. BIBLIO70/71

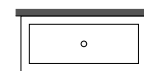
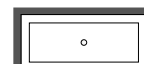
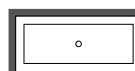
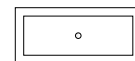
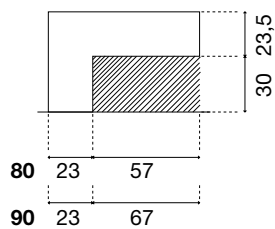
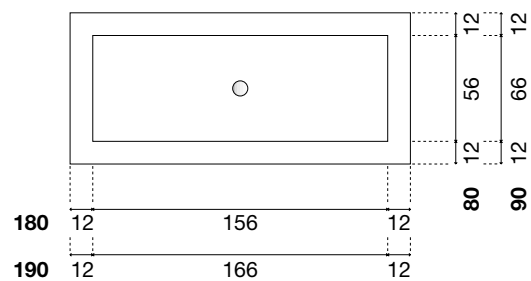

**BIBLIO70** H 53,5 P 80 L 180 cm

**BIBLIO71** H 53,5 P 90 L 190 cm

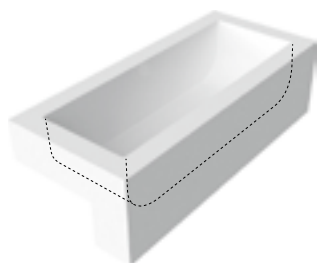

art. BIBLIO80/81

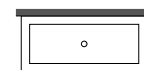
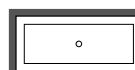
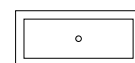
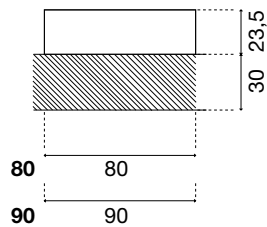
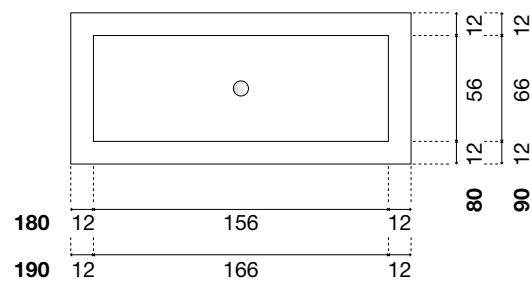

**BIBLIO80** H 53,5 P 80 L 180 cm

**BIBLIO81** H 53,5 P 90 L 190 cm

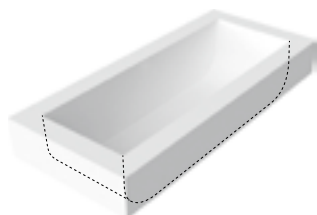

# BIBLIO

art. BIBLIO103

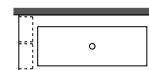
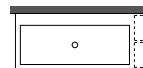
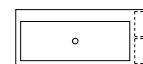
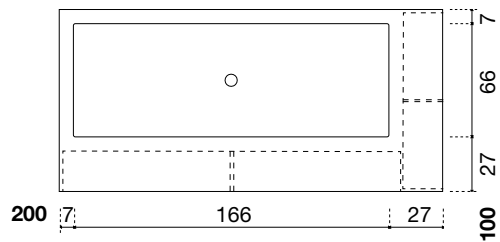

**BIBLIO103** H 53,5 P 100 L 200 cm



art. BIBLIOXL

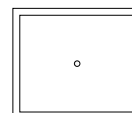
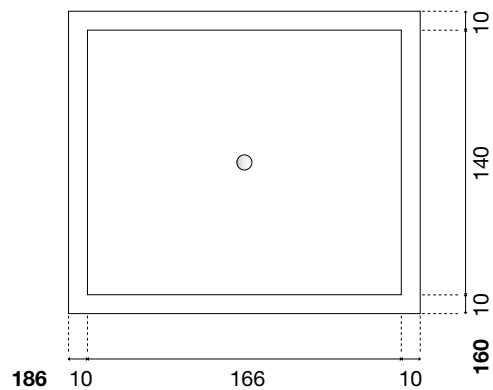

**BIBLIOXL** H 53,5 P 160 L 186 cm



# BIBLIO

## POSIZIONAMENTO RUBINETTERIA / TAP POSITION

Vista dall'alto del posizionamento del rubinetto sul bordo da 17 cm lato lungo vasca opzioni **A-B-C** degli art. **BK701, BK702, AY701SA, AY701LU, AY702SA e AY702LU.**

*Top view of tap position on border 17 cm long side options **A-B-C** of art. **BK701, BK702, AY701SA, AY701LU, AY702SA and AY702LU.***

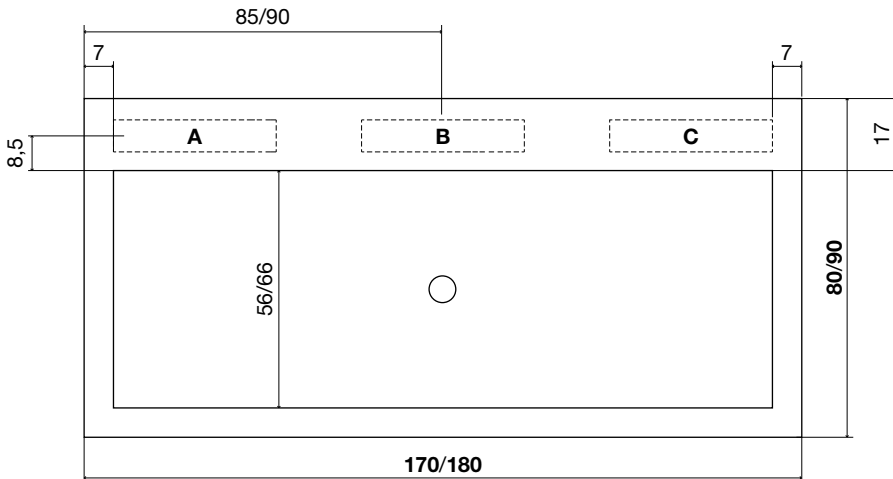

Vista dall'alto e laterale del posizionamento del rubinetto sul bordo da 17 cm lato corto vasca degli art. **BK701, BK702, AY701SA, AY701LU, AY702SA e AY702LU.**

*Top and side view of tap position on center of border 17 cm short side of art. **BK701, BK702, AY701SA, AY701LU, AY702SA and AY702LU.***

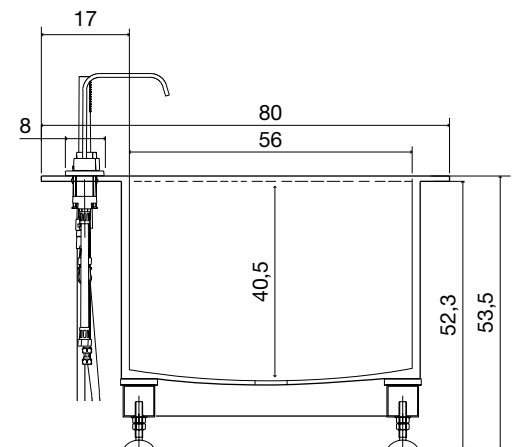
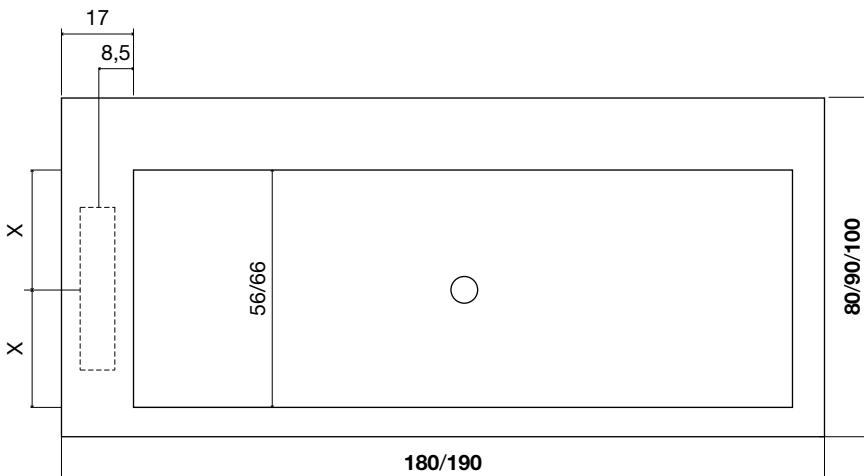



# BIBLIO

art. BK701

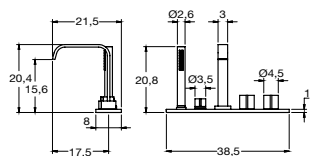

art. AY701SA  
art. AY701LU

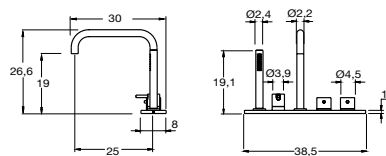

art. BK702

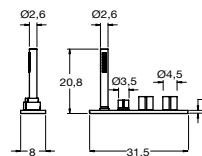

art. AY702SA  
art. AY702LU

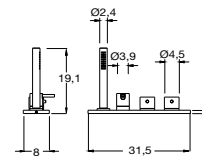

art. BK903

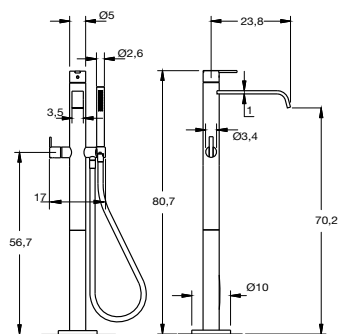

art. AY903SA  
art. AY903LU

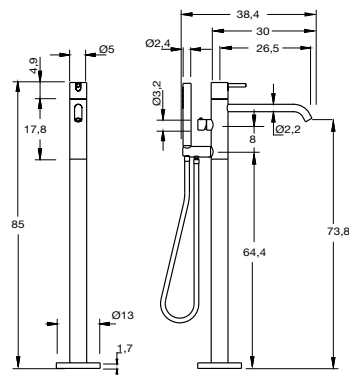

art. TB933

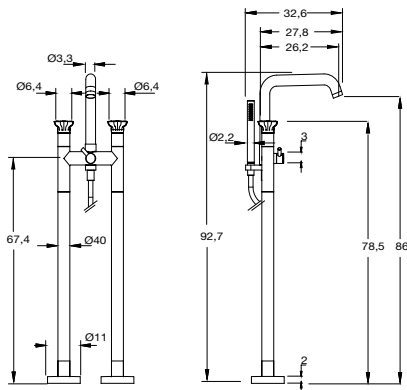

Tutti i modelli **art. BIBLIO** sono corredati di un sistema di scarico illustrato di seguito, completo di troppopieno nascosto che funziona mediante l'utilizzo del principio dei vasi comunicanti (A), sifone (D), e piletta con scarico a pressione "klik-clak", che può svolgere anche la funzione di erogazione (B), da attivare solo in abbinamento ai rubinetti **art. BK702, AY702SA, AY702LU** o a qualsiasi rubinetto bordo vasca sprovvisto di bocca di erogazione.

All models of the **art. BIBLIO** bath tub come with a drainage system as illustrated below complete with a hidden overflow which functions utilizing the connection tubes (A), trap (D) and pressure plug which can also be used as a spout (B), to activate only in conjunction with **art. BK702, AY702SA, AY702LU** or any bath rim mounting set without a bath spout according to instructions given below.

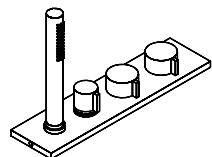
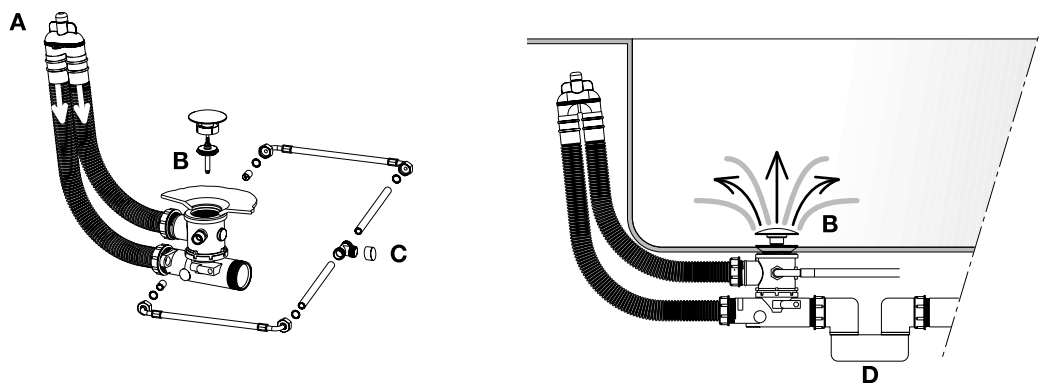

Con **art. BK702 / AY702SA / AY702LU**

Per rendere attivo il sistema di erogazione direttamente dalla piletta di scarico (B), togliere il tappo "C" e collegare al carico dell'acqua.

With **art. BK702 / AY702SA / AY702LU**

Remove cap "C" and connect to water outlet to activate directly from drain (B).

# BIBLIO

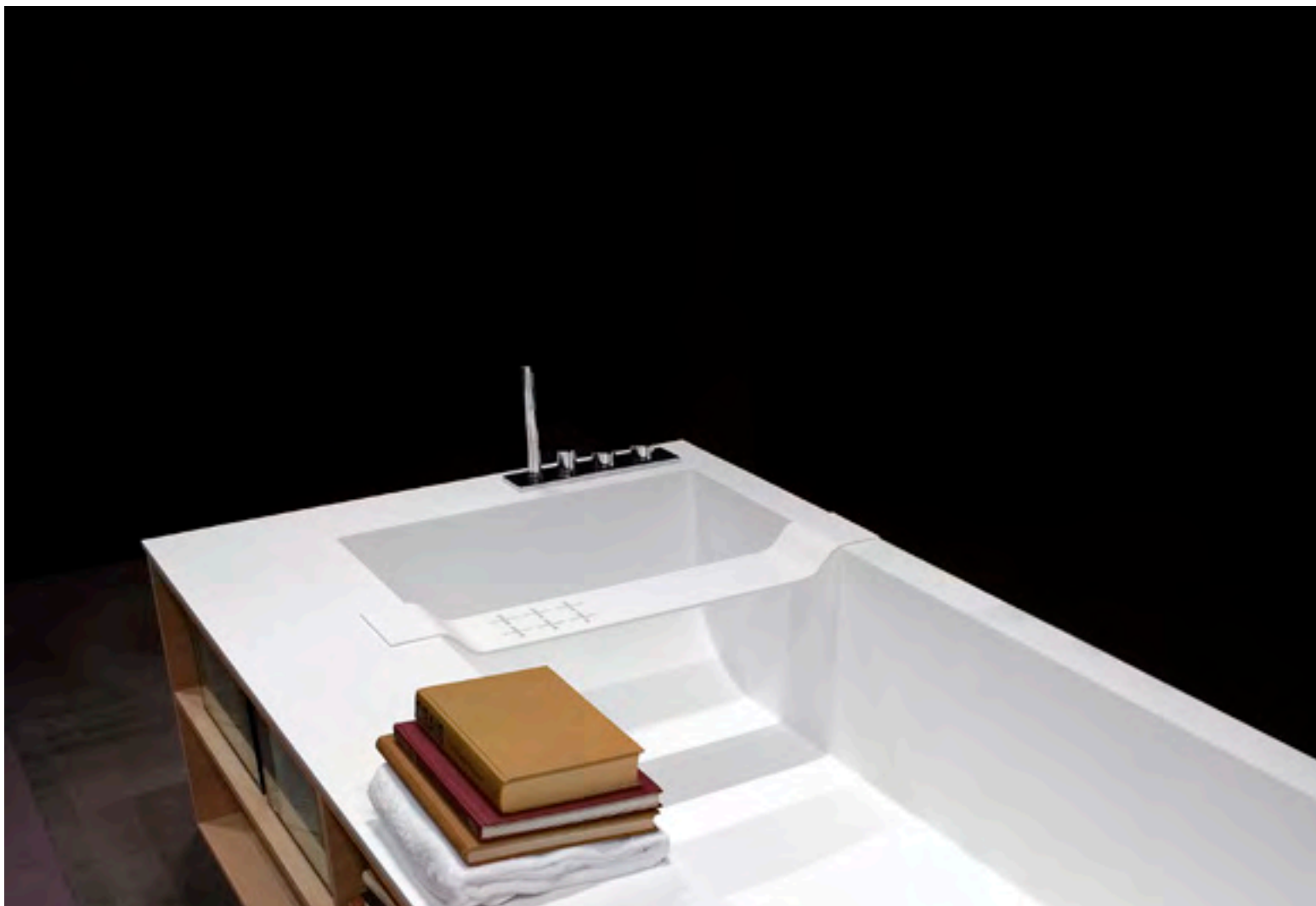

vasche  
tubs

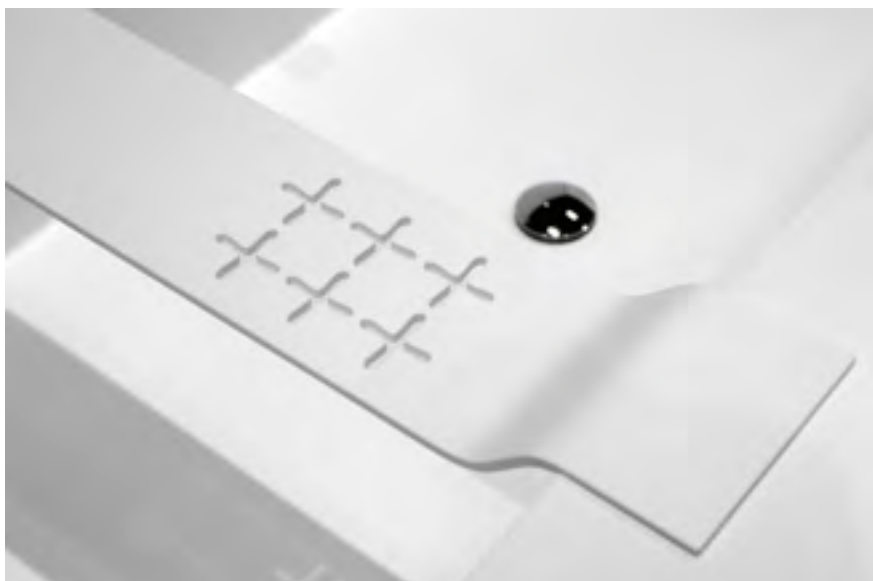

art. **BRIDGE10** L 70 P 14 H 4,6 cm

art. **BRIDGE11** L 80 P 14 H 4,6 cm

Tavoletta sagomata in Corian portaoggetti, per vasca da bagno  
Art. BIBLIO.

Corian soap tray for bathtub Art. *BIBLIO*.

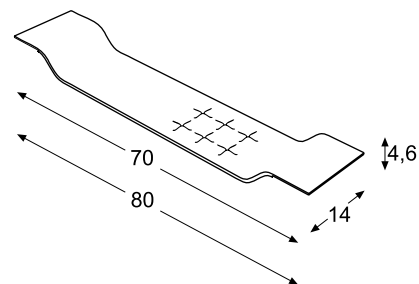







art. **DIMORA42** L 144 P 144 H 54,2 cm / peso vasca tub weight 260 kg / capacità capacity 250 L + art. **COVO46**

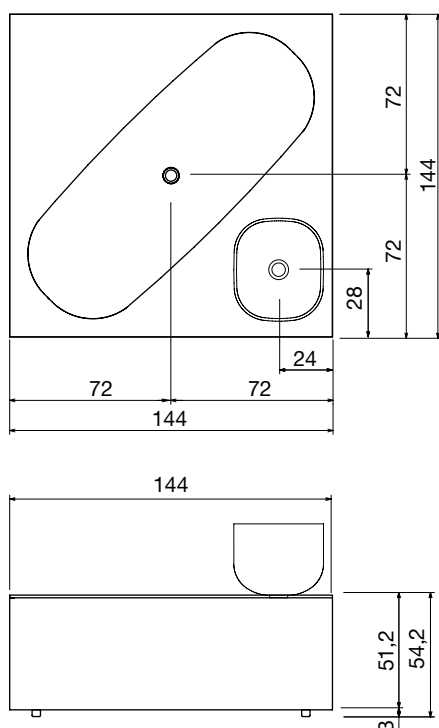

art. **BK702**

**art. DIMORA42**

Vasca da bagno rettangolare in Corian, rivestita su 4 lati con pannelli in diversi materiali, completa di piedini regolabili e piletta con scarico a pressione klik-clak.

*Corian rectangular bathtub, covered on 4 sides with panels in various materials complete with regulating feet, drain and pressure plug.*

**art. COVO46**

Lavabo sopra piano in Corian completo di piletta con scarico libero e raccordo per sifone, abbinabile con vasca Art. DIMORA42.

*Top mount Corian sink complete with drain pipe fitting and open plug combinable with bathtub Art. DIMORA42.*



# DIMORA



vasche  
tubs

art. DIMORA52 L 170 P 125 H 54,2 cm / peso vasca tub weight 214 kg / capacità capacity 250 L

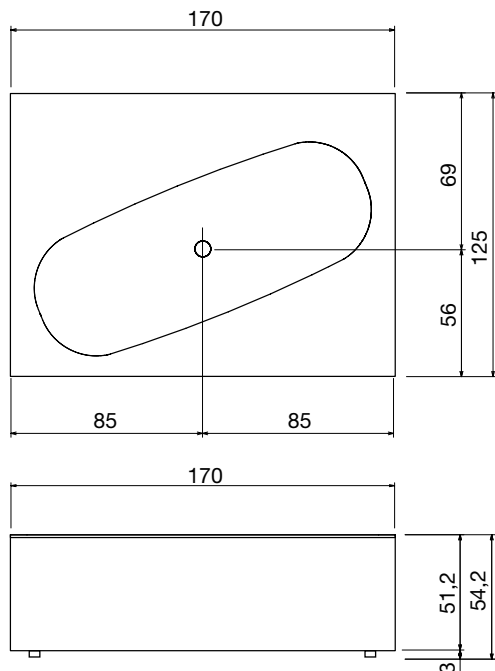

Vasca da bagno rettangolare in Corian, rivestita su 4 lati con pannelli in diversi materiali, completa di piedini regolabili e piletta con scarico a pressione klik-clak.

*Corian rectangular bathtub, covered on 4 sides with panels in various materials complete with regulating feet, drain and pressure plug.*





# DIMORA



vasche  
tubs

art. DIMORA32 L 180 P 80 H 54,2 cm / peso vasca tub weight 178 kg / capacità capacity 250 L

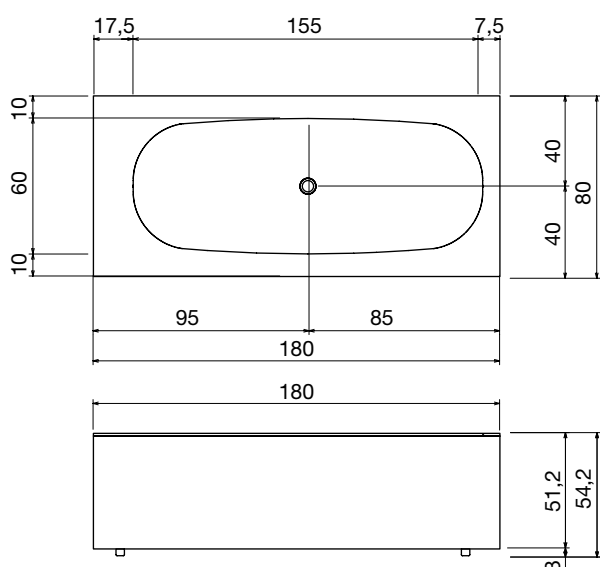

art. AY702LU

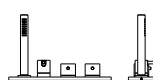

Vasca da bagno rettangolare in Corian, con bordo rubinetteria laterale dx o sx, rivestita su 4 lati con pannelli in diversi materiali, completa di piedini regolabili e piletta con scarico a pressione klik-clak.

Corian rectangular bathtub with left or right side rim for tap mounting, covered on 4 sides with panels in various materials complete with regulating feet, drain and pressure plug.







# DIMORA



vasche  
tubs

art. DIMORA12 L 120 P 80 H 54,2 cm / peso vasca tub weight 150 kg / capacità capacity 200 L

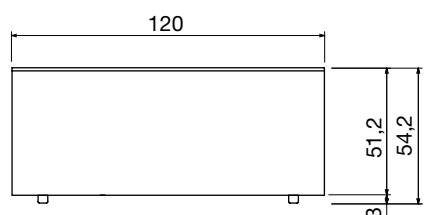
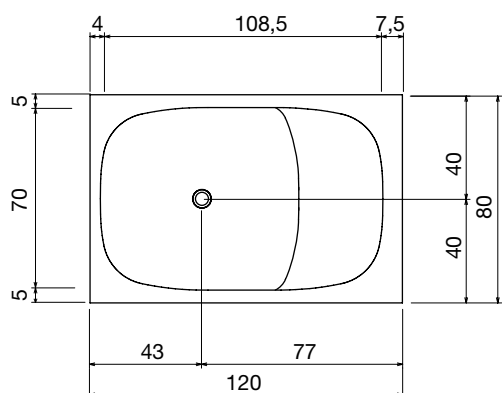

art. AY150SA

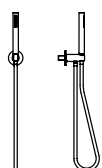

art. AY654RSA

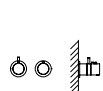

art. SBALZO

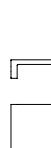

Vasca da bagno rettangolare in Corian, rivestita su 4 lati con pannelli in diversi materiali, completa di piedini regolabili e piletta con scarico a pressione klik-clak.

Corian rectangular bathtub, covered on 4 sides with panels in various materials complete with regulating feet, drain and pressure plug.



# DIMORA



vasche  
tubs

art. DIMORA22 L 170 P 80 H 54,2 cm / peso vasca tub weight 176 kg / capacità capacity 250 L

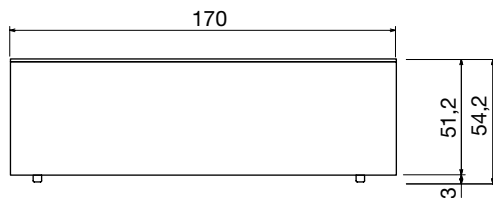
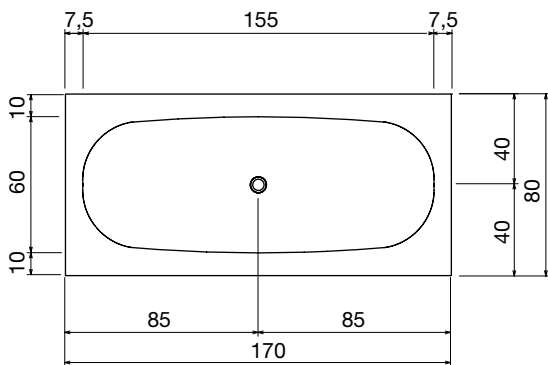

art. AY150SA

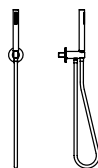

art. AY654RSA



art. SBALZO



Vasca da bagno rettangolare in Corian, rivestita su 4 lati con pannelli in diversi materiali, completa di piedini regolabili e piletta con scarico a pressione klik-clak.

Corian rectangular bathtub, covered on 4 sides with panels in various materials complete with regulating feet, drain and pressure plug.



# DIMORA

art. DIMORA10-11-12

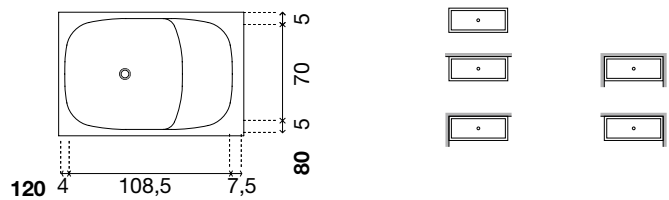

DIMORA20-21-22

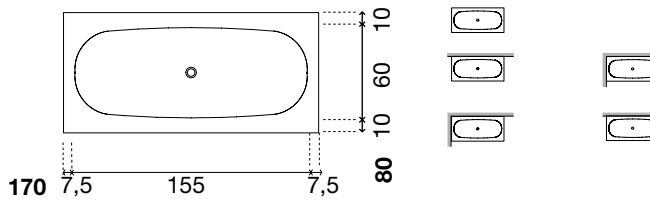

**DIMORA11** L 120 P 80 H 54,2 cm   **DIMORA10** L 120 P 80 H 54,2 cm   **DIMORA12** L 120 P 80 H 54,2 cm   **DIMORA21** L 170 P 80 H 54,2 cm   **DIMORA20** L 170 P 80 H 54,2 cm   **DIMORA22** L 170 P 80 H 54,2 cm



Art. DIMORA30-31-32

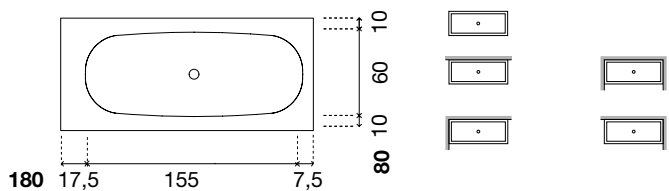

Art. DIMORA40-41-42

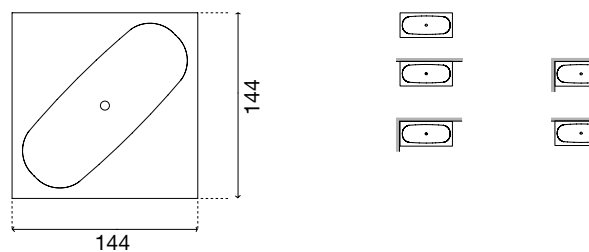

**DIMORA31** L 180 P 80 H 54,2 cm   **DIMORA30** L 180 P 80 H 54,2 cm   **DIMORA32** L 180 P 80 H 54,2 cm   **DIMORA41** L 144 P 144 H 54,2 cm   **DIMORA40** L 144 P 144 H 54,2 cm   **DIMORA42** L 144 P 144 H 54,2 cm



Art. DIMORA50-51-52

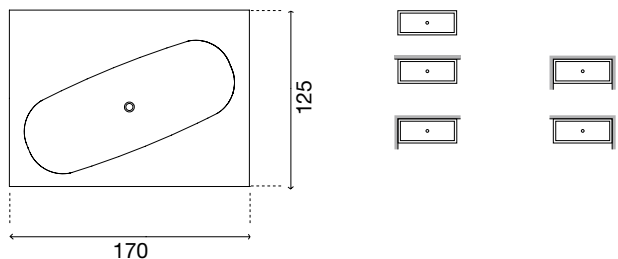

**DIMORA51** L 170 P 125 H 54,2 cm   **DIMORA50** L 170 P 125 H 54,2 cm   **DIMORA52** L 170 P 125 H 54,2 cm

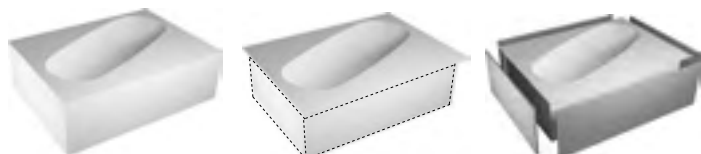











vasche  
tubs





# SOLIDEA



vasche  
tubs

art. SOLIDEA190 L 190 P 130 H 55 cm / peso vasca tub weight 900 kg / capacità capacity 550 L  
 art. SOLIDEA210 L 210 P 130 H 55 cm / peso vasca tub weight 950 kg / capacità capacity 620 L

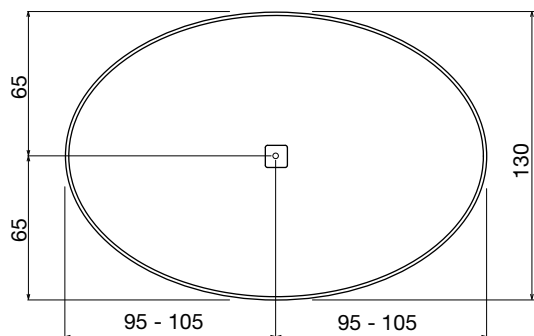

art. AY903LU

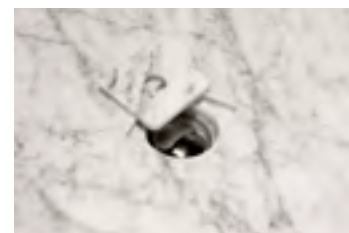
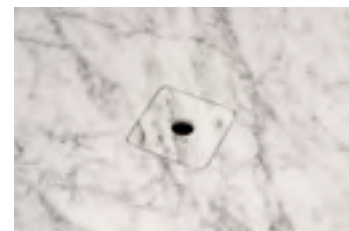
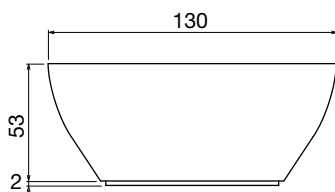
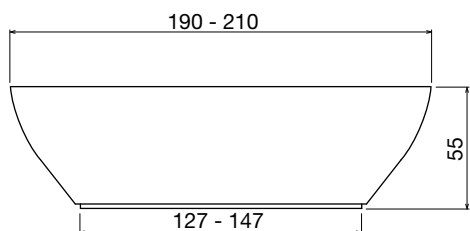
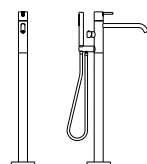

## Marmo di Carrara / Stone Grey / Nero Marquina

Vasca da bagno ovale in pietra, completa di piletta con sistema di scarico a pressione click-clack, sifone e tubo flessibile.  
**N.B.** Per l'ispezione, si consiglia di realizzare un pozzetto esterno (vedere schede tecniche).

*Oval stone bathtub complete with drain and pressure plug, siphon and flexible hose.*

**P.S.** We advise an exterior inspection window (see technical drawings).







art. BAiA L 185 P 90 H 50 cm / peso vasca tub weight 800 kg / capacità capacity 400

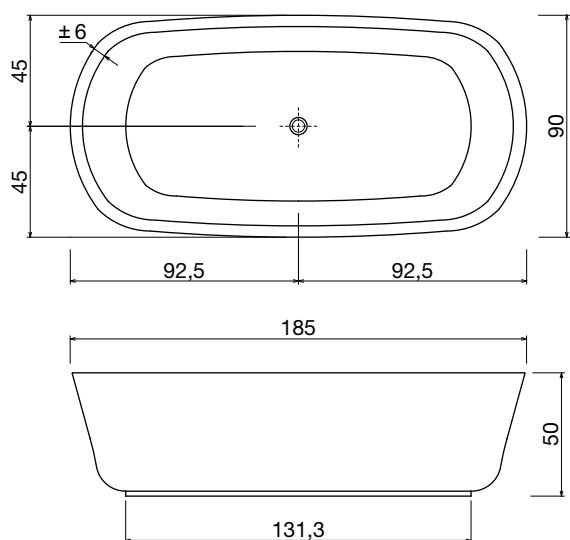

**Pietra Luna / Stone Grey**

art. BK903N

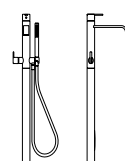

Vasca da bagno ovale in pietra, completa di piletta con sistema di scarico a pressione click-clack, sifone e tubo flessibile.  
**N.B.** Per l'ispezione, si consiglia di realizzare un pozzetto esterno (vedere schede tecniche).

*Oval stone bathtub complete with drain and pressure plug, siphon and flexible hose.*  
**P.S.** We advise an exterior inspection window (see technical drawings).







# VASCABARCA/BARCAVASCA design Anne e Patrick Poirier



vasche  
tubs

art. VASCABARCA/BARCAVASCA L 260 P 140 H 56 cm / peso vasca tub weight 1.600 kg / capacità capacity 400 L

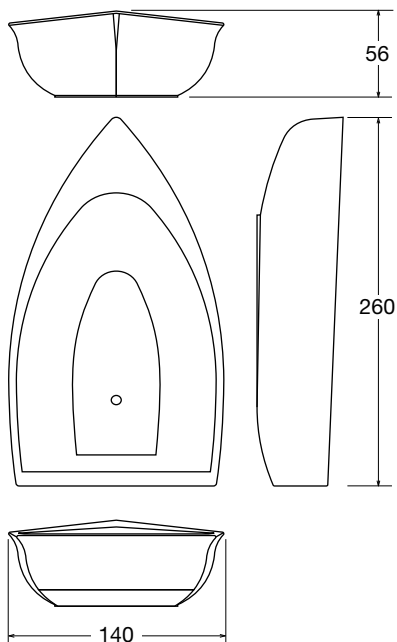

## EDIZIONE LIMITATA / LIMITED EDITION

Vasca da bagno in Pietra Stone Grey, completa di piletta con sistema di scarico a pressione click-clack, sifone e tubo flessibile.  
**N.B.** Per l'ispezione, si consiglia di realizzare un pozzetto esterno (vedere schede tecniche).

*Stone bathtub in "Stone Grey" complete with drain and pressure plug, sphon and flexible hose.*

**P.S.** We advise an exterior inspection window (see technical drawings).

Di quest'opera saranno realizzati 10 esemplari in pietra, firmati e numerati in numeri romani dagli artisti; il committente potrà, se vorrà, personalizzare la propria vascabarca con un nome a sua scelta che sarà inciso a poppa.

*Of this masterpiece only 10 pieces will be made out of stone, signed and numbered with roman numbers from the artists; the buyer can choose, if wishes, to personalize their own vascabarca with a name which can be carved at stern.*





**PIATTI E BOX DOCCIA**  
**TRAYS AND SHOWER ENCLOSURES**

piatti e box doccia  
trays and shower enclosures







piatti e box doccia  
trays and shower enclosures







piatti e box doccia  
trays and shower enclosures





piatti e box doccia  
trays and shower enclosures







piatti e box doccia  
trays and shower enclosures



BILICO







piatti e box doccia  
trays and shower enclosures



# BILICO

art. BILICO1N

Box doccia dx o sx in vetro temperato spess. 8 mm per piatti doccia Art. ZEROLUX\_ST, Art. ZEROMATT\_ST, Art. ZEROLUX\_XL, Art. ZEROMATT\_ML, Art. ZEROSTONE\_ML, Art. 00\_XL e Art. 00\_ST tra pareti in nicchia, completo di perno e barra di sostegno.

Right or left shower enclosure in 8 mm tempered glass for shower tray Art. ZEROLUX\_ST, Art. ZEROMATT\_ST, Art. ZEROLUX\_XL, Art. ZEROMATT\_ML, Art. ZEROSTONE\_ML, Art. 00\_XL and Art. 00\_ST within a recessed area, complete with pin and supporting bar.

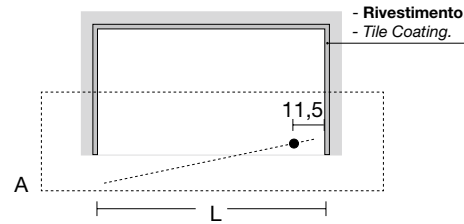
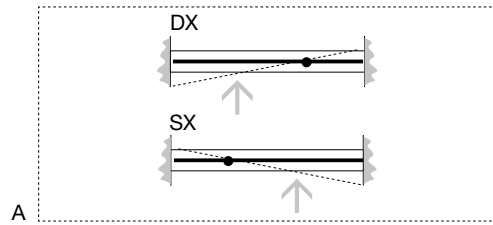

	da/a - from/to
H	L
198,3	67/77
	78/90

art. BILICO5N

Box doccia dx o sx in vetro temperato spess. 8 mm per piatti doccia Art. ZEROLUX\_ST, Art. ZEROMATT\_ST, Art. ZEROLUX\_XL, Art. ZEROMATT\_ML, Art. ZEROSTONE\_ML, Art. 00\_XL e Art. 00\_ST tra pareti in nicchia, completo di perno centrale e barra di sostegno.

Right or left shower enclosure in 8 mm tempered glass for shower tray Art. ZEROLUX\_ST, Art. ZEROMATT\_ST, Art. ZEROLUX\_XL, Art. ZEROMATT\_ML, Art. ZEROSTONE\_ML, Art. 00\_XL and Art. 00\_ST within a recessed area, complete with center pin and supporting bar.

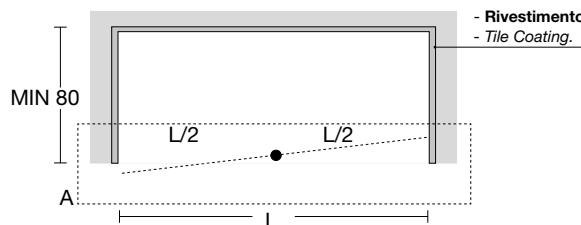
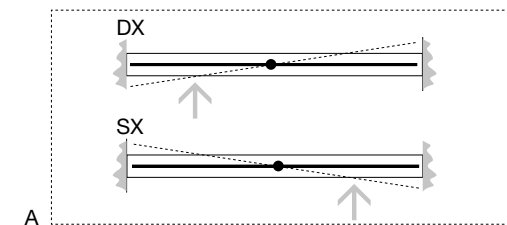
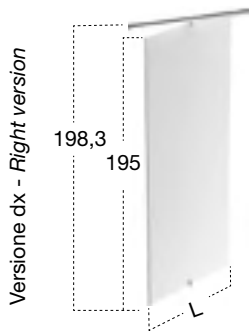

	da/a - from/to
H	L
198,3	117/137

piatti e box doccia  
trays and shower enclosures



# BILICO

## art. BILICO3N

Box doccia dx o sx in vetro temperato spess. 8 mm per piatt doccia Art. ZEROMATT\_MLD, Art. ZEROSTONE\_MLD, Art. ZEROLUX\_ST, Art. ZEROMATT\_ST, Art. ZEROLUX\_XL, Art. ZEROMATT\_ML, Art. ZEROSTONE\_ML, Art. 00\_XL e Art. 00\_ST tra pareti in nicchia, completo di perno, barra di sostegno e profilo a parete in acciaio inox satinato AISI 304.

*Right or left shower enclosure in 8 mm tempered glass for shower tray Art. ZEROMATT\_MLD, Art. ZEROSTONE\_MLD, Art. ZEROLUX\_ST, Art. ZEROMATT\_ST, Art. ZEROLUX\_XL, Art. ZEROMATT\_ML, Art. ZEROSTONE\_ML, Art. 00\_XL and Art. 00\_ST within a recessed area, complete with pin, supporting bar and satin stainless steel wall profile AISI 304.*

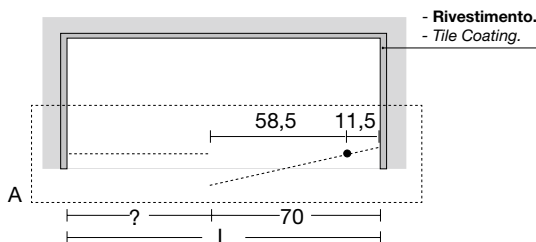
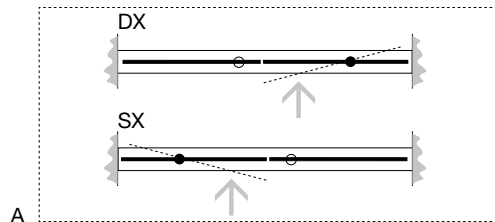
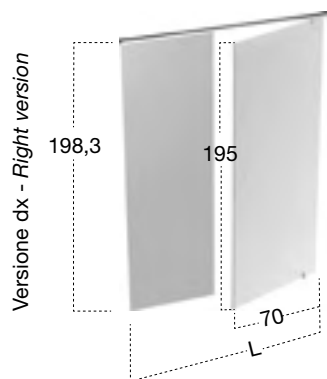

da/a - from/to	
H	L
198,3	91/117
	118/137
	138/157
	158/177
	178/197

## art. BILICO7N

Box doccia dx o sx in vetro temperato spess. 8 mm per piatt doccia Art. 00\_XL, Art. 00\_ST, Art. ZEROLUX\_XL, Art. ZEROLUX\_ST, Art. ZEROMATT\_ST, Art. ZEROMATT\_ML, Art. ZEROMATT\_MLD, Art. ZEROSTONE\_ML e Art. ZEROSTONE\_MLD tra pareti in nicchia, completo di perno, barra di sostegno e profili a parete in acciaio inox satinato AISI 304.

*Right or left shower enclosure in 8 mm tempered glass for shower tray Art. 00\_XL, Art. 00\_ST, Art. ZEROLUX\_XL, Art. ZEROLUX\_ST, Art. ZEROMATT\_ST, Art. ZEROMATT\_ML, Art. ZEROMATT\_MLD, Art. ZEROSTONE\_ML and Art. ZEROSTONE\_MLD within a recessed area, complete with center pin, supporting bar and wall profiles in satin stainless steel AISI 304.*

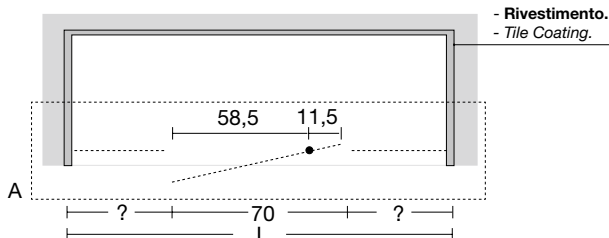
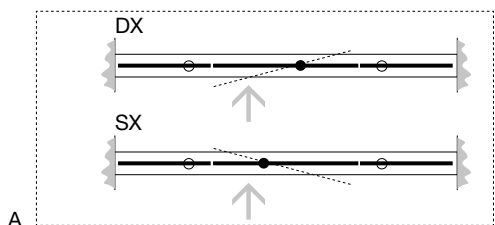
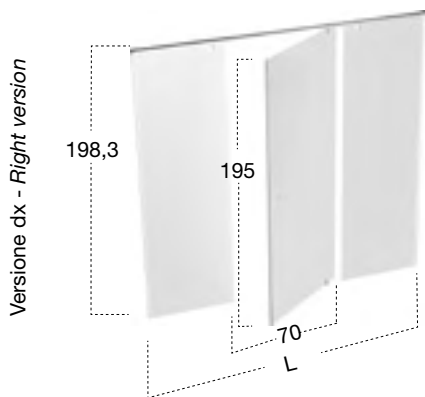

da/a - from/to	
H	L
198,3	157/177
	178/197

# BILICO

art. **BILICO80AL** P 67/77  
 art. **BILICO90AL** P 78/89

Box doccia dx o sx in vetro temperato spess. 8 mm per piatti doccia Art. ZEROLUX\_ST, Art. ZEROMATT\_ST, Art. ZEROLUX\_XL, Art. ZEROMATT\_ML, Art. ZEROSTONE\_ML, Art. 00\_XL e Art. 00\_ST tra pareti in angolo, completo di perno, barra di sostegno e profilo a parete in acciaio inox satinato AISI 304.

Right or left shower enclosure in 8 mm tempered glass for shower tray Art. ZEROLUX\_ST, Art. ZEROMATT\_ST, Art. ZEROLUX\_XL, Art. ZEROMATT\_ML, Art. ZEROSTONE\_ML, Art. 00\_XL and Art. 00\_ST within a recessed area, complete with pin, supporting bar and wall profile in satin stainless steel AISI 304.

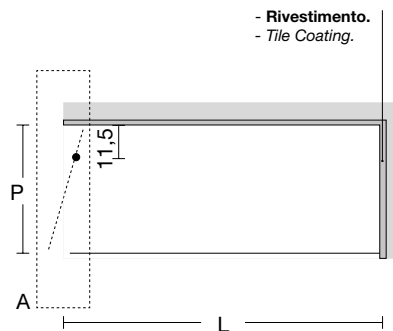
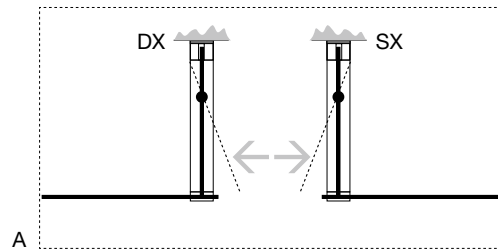
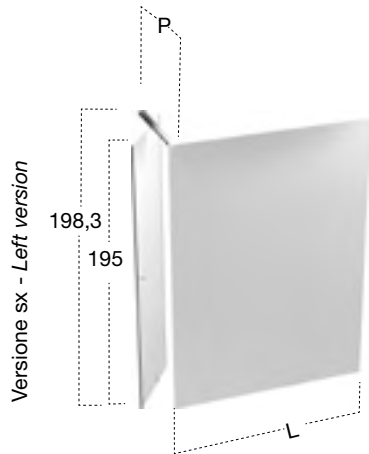

P	da/a - from/to
67/77	L 89/119 120/139
78/89	89/119 120/139

art. **BILICO80AF** P 67/77  
 art. **BILICO90AF** P 78/89

Box doccia dx o sx in vetro temperato spess. 8 mm per piatti doccia Art. ZEROLUX\_ST, Art. ZEROMATT\_ST, Art. ZEROLUX\_XL, Art. ZEROMATT\_ML, Art. ZEROSTONE\_ML, Art. 00\_XL e Art. 00\_ST tra pareti in angolo, completo di perno, barra di sostegno e profilo a parete in acciaio inox satinato AISI 304.

Right or left shower enclosure in 8 mm tempered glass for shower tray Art. ZEROLUX\_ST, Art. ZEROMATT\_ST, Art. ZEROLUX\_XL, Art. ZEROMATT\_ML, Art. ZEROSTONE\_ML, Art. 00\_XL e Art. 00\_ST within a corner, complete with pin, supporting bar and wall profile in satin stainless steel AISI 304.

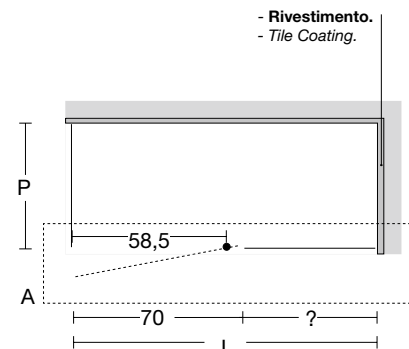
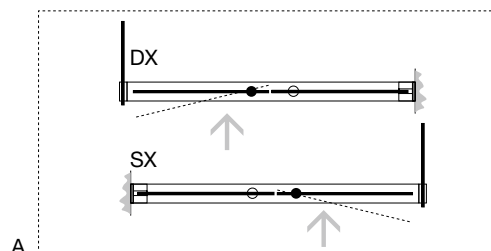
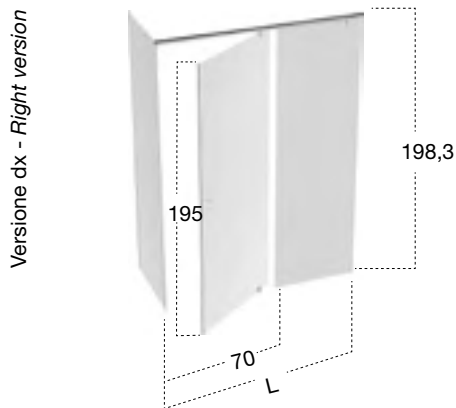

P	da/a - from/to
67/77	L 89/119 120/139 140/159 160/179 180/199
78/89	89/119 120/139 140/159 160/179 180/199

piatti e box doccia  
trays and shower enclosures





# ZEROLUX - ZEROMATT design AL Studio

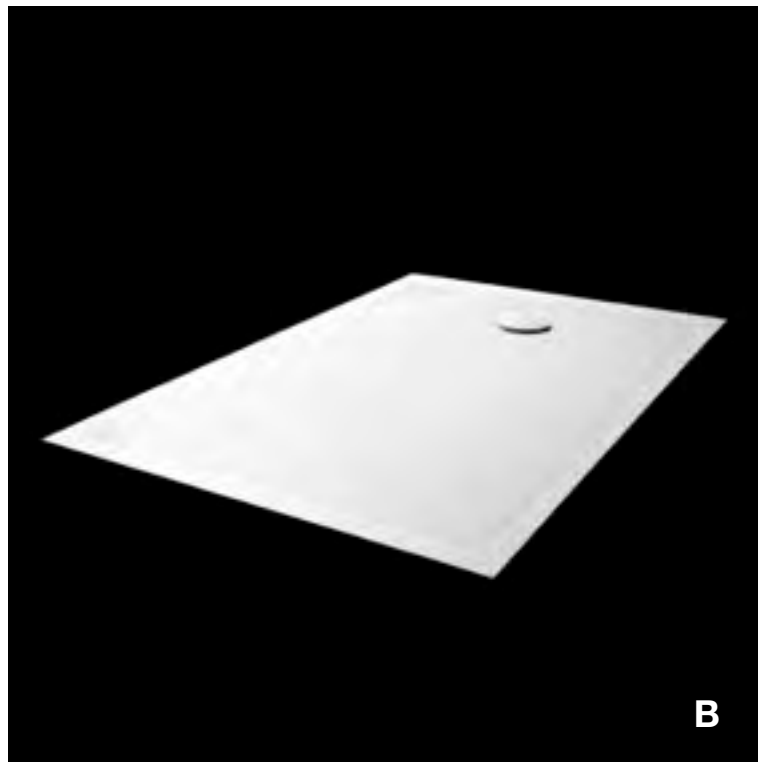
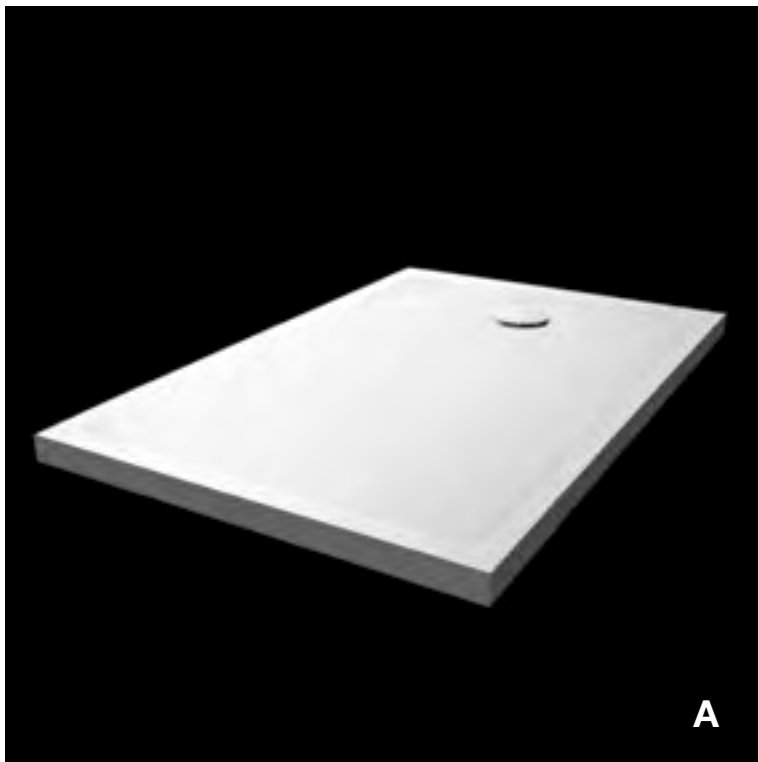

art. **ZEROLUX\_ST**      finitura lucida - glossy finish  
 art. **ZEROMATT\_ST**      finitura opaca - matt finish

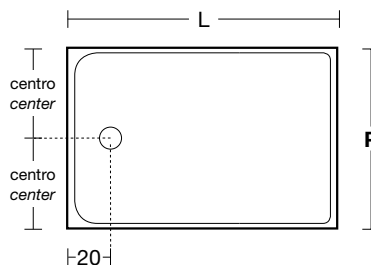
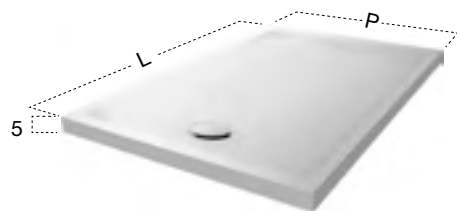

H	P	L	ART.
5	80	80	<b>ZEROLUX_ST8080 / ZEROMATT_ST8080</b>
		100	<b>ZEROLUX_ST80100 / ZEROMATT_ST80100</b>
		120	<b>ZEROLUX_ST80120 / ZEROMATT_ST80120</b>
		140	<b>ZEROLUX_ST80140 / ZEROMATT_ST80140</b>
		160	<b>ZEROLUX_ST80160 / ZEROMATT_ST80160</b>
90	90	90	<b>ZEROLUX_ST9090 / ZEROMATT_ST9090</b>
		100	<b>ZEROLUX_ST90100 / ZEROMATT_ST90100</b>
		120	<b>ZEROLUX_ST90120 / ZEROMATT_ST90120</b>
		140	<b>ZEROLUX_ST90140 / ZEROMATT_ST90140</b>
		160	<b>ZEROLUX_ST90160 / ZEROMATT_ST90160</b>

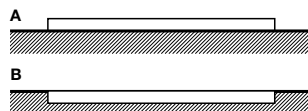

Piatto doccia rettangolare da appoggio (A) o da incasso (B) in Ceramilux in finitura lucida o opaca, completo di sifone e piletta con scarico libero.

Rectangular top mount (A) or encased (B) shower tray in Ceramilux in glossy or matt finish, complete with siphon and open drain.

piatti e box doccia  
trays and shower enclosures



# ZEROLUX



- art. ZEROLUX\_XL80    P 80 L 81/160
- art. ZEROLUX\_XL90    P 90 L 91/160
- art. ZEROLUX\_XL180    P 80 L 161/250
- art. ZEROLUX\_XL190    P 90 L 161/250

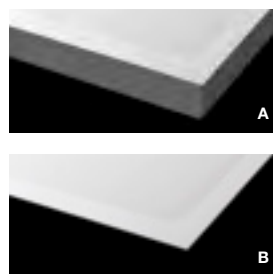
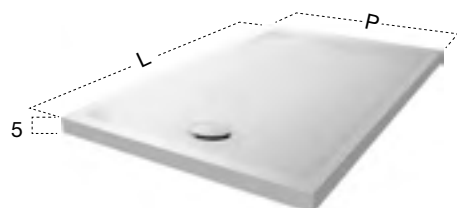

H	L
5	81/90
	91/100
	101/110
	111/120
	121/130
	131/140
	141/150
	151/160
	161/170
	171/180
	181/190
	191/200
	201/210
	211/220
	221/230
	231/240
	241/250

## DIMENSIONI A MISURA - CUSTOM MADE MEASUREMENTS

### art. ZEROLUX\_XL80 - art. ZEROLUX\_XL90

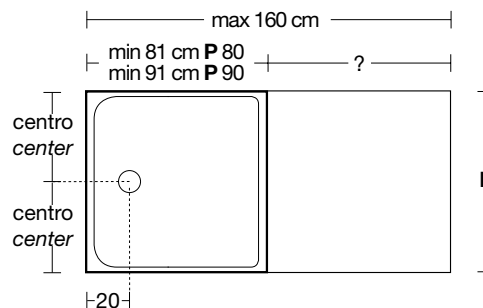

**N.B.** L'invaso con pendenza verso lo scarico, si sviluppa su una lunghezza di 81 cm per Art. ZEROLUX\_XL80, di 91 cm per Art. ZEROLUX\_XL90. La parte restante in lunghezza ha una superficie piana.  
**P.S.** The slope towards the drain is over a length of 81 cm for the Art. ZEROLUX\_XL80, 91 cm for the Art. ZEROLUX\_XL90. The remaining part of the tray has a flat surface.

### art. ZEROLUX\_XL180 - art. ZEROLUX\_XL190

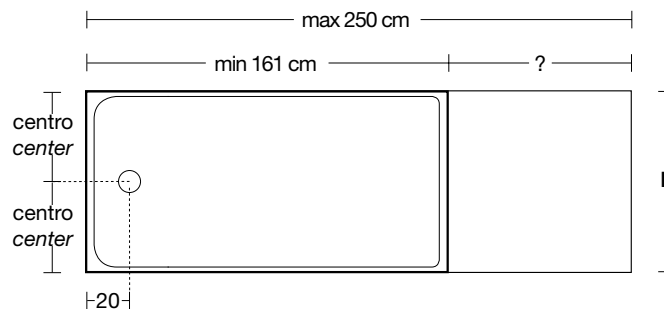

**N.B.** L'invaso con pendenza verso lo scarico, si sviluppa su una lunghezza di 161 cm. La parte restante in lunghezza ha una superficie piana.  
**P.S.** The slope towards the drain is over a length of 161 cm. The remaining part of the tray has a flat surface.

Piatto doccia rettangolare da appoggio (A) o da incasso (B) in Ceramilux lucido, completo di sifone e piletta con scarico libero.

Rectangular top mount (A) or encased (B) shower tray in glossy Ceramilux, complete with siphon and open drain.

piatti e box doccia  
trays and shower enclosures





# ZEROMATT

- art. ZEROMATT\_ML70 P 70 L 70/250
- art. ZEROMATT\_ML80 P 80 L 80/250
- art. ZEROMATT\_ML90 P 90 L 90/250

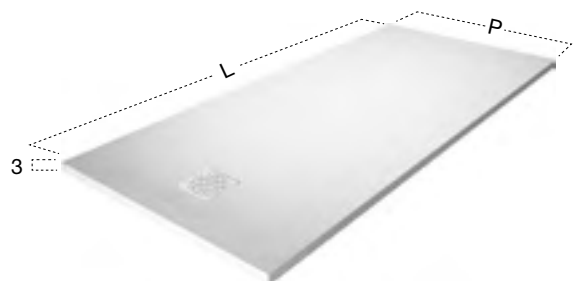

H	L
3	70/80
	80/90
	90/100
	101/110
	111/120
	121/130
	131/140
	141/150
	151/160
	161/170
	171/180
	181/190
	191/200
	201/210
	211/220
	221/230
	231/240
	241/250

## DIMENSIONI A MISURA - CUSTOM MADE MEASUREMENTS

art. ZEROMATT\_ML70 / ZEROMATT\_ML80 / ZEROMATT\_ML90

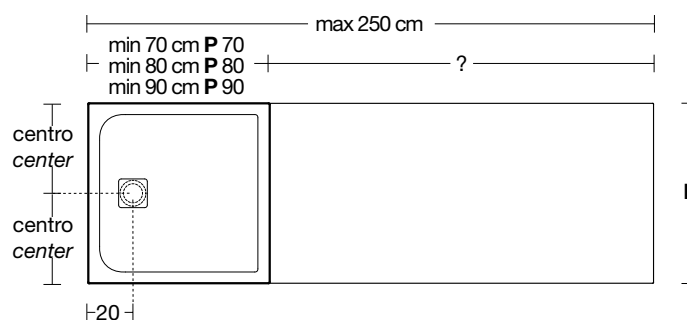

**N.B.** L'invaso con pendenza verso lo scarico, si sviluppa su una lunghezza di 70 cm per Art. ZEROMATT\_ML70, di 80 cm per Art. ZEROMATT\_ML80, di 90 cm per Art. ZEROMATT\_ML90. La parte restante in lunghezza ha una superficie piana.

**PS.** The slope towards the drain is over a length of 70 cm for the Art. ZEROMATT\_ML70, 80 cm for the Art. ZEROMATT\_ML80, 90 cm for the art. ZEROMATT\_ML90. The remaining part of the tray has a flat surface.

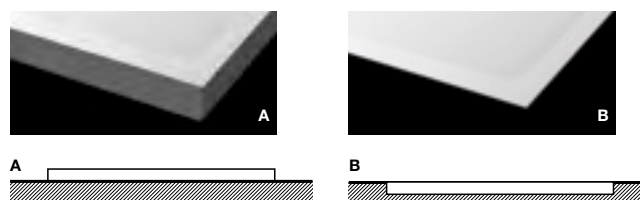

Piatto doccia rettangolare da appoggio (A) o da incasso (B) in Ceramilux in finitura opaca, completo di sifone e piletta con scarico libero.

Rectangular top mount (A) or encased (B) shower tray in Ceramilux in matt finish, complete with siphon and open drain.

- art. ZEROMATT\_MLD180 P 80 L 160/250
- art. ZEROMATT\_MLD190 P 90 L 160/250

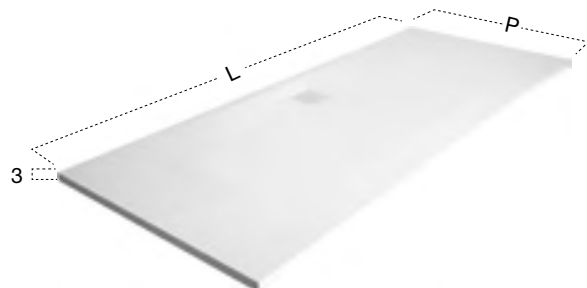

H	L
3	160/170
	171/180
	181/190
	191/200
	201/210
	211/220
	221/230
	231/240
	241/250

## DIMENSIONI A MISURA - CUSTOM MADE MEASUREMENTS

art. ZEROMATT\_MLD180 / ZEROMATT\_MLD190

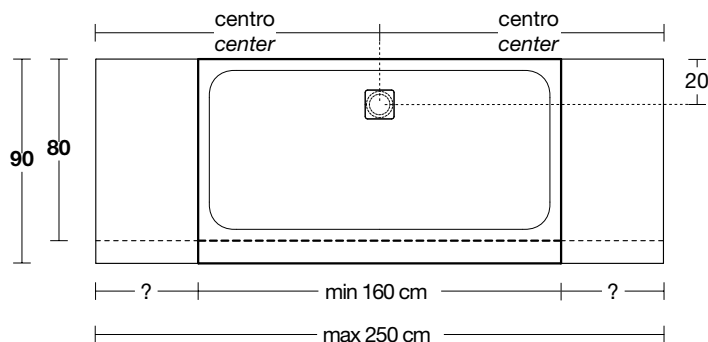

**N.B.** L'invaso con pendenza verso lo scarico, si sviluppa sulla lunghezza di 160 cm e sulla profondità di 80 cm, sia per Art. ZEROMATT\_MLD180 che per Art. ZEROMATT\_MLD190. La parte restante in lunghezza ha una superficie piana.

**PS.** The slope towards the drain is over a length of 160 cm, and over a depth of 80 cm, in Art. ZEROMATT\_MLD180 and Art. ZEROMATT\_MLD190. The remaining part of the tray has a flat surface.

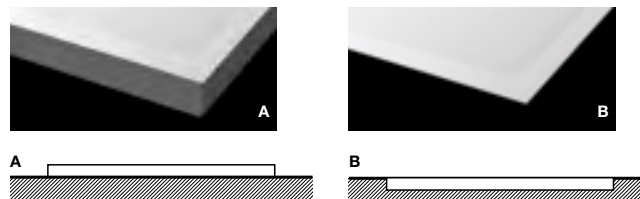

Piatto doccia rettangolare da appoggio (A) o da incasso (B) in Ceramilux in finitura opaca, completo di sifone e piletta con scarico libero.

Rectangular top mount (A) or encased (B) shower tray in Ceramilux in matt finish, complete with siphon and open drain.

piatti e box doccia  
trays and shower enclosures



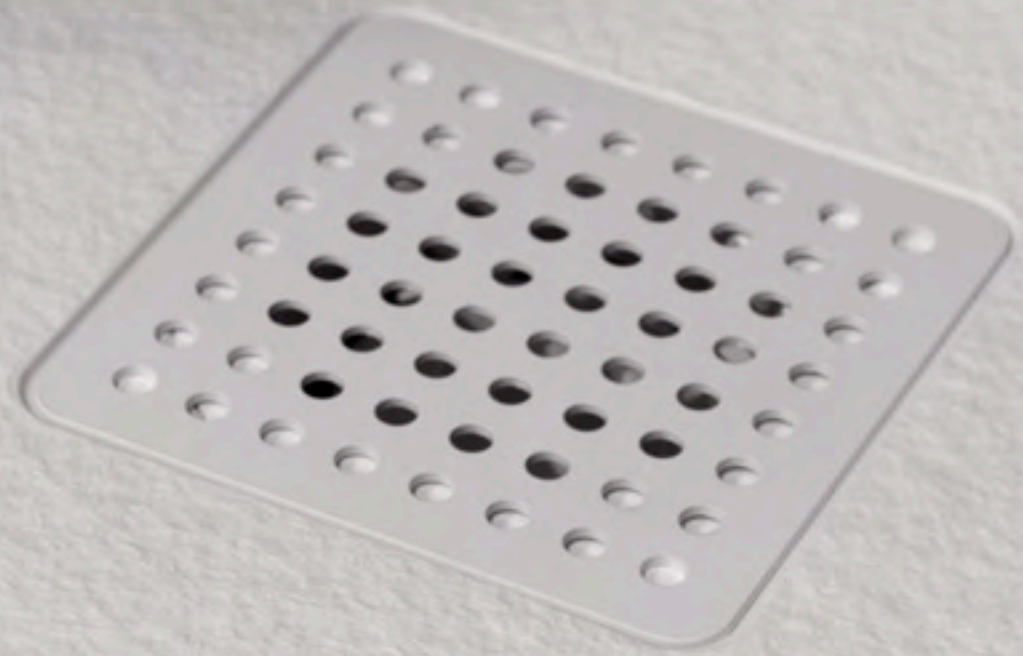



# ZEROSTONE

- art. **ZEROSTONE\_ML70** P 70 L 70/250
- art. **ZEROSTONE\_ML80** P 80 L 80/250
- art. **ZEROSTONE\_ML90** P 90 L 90/250

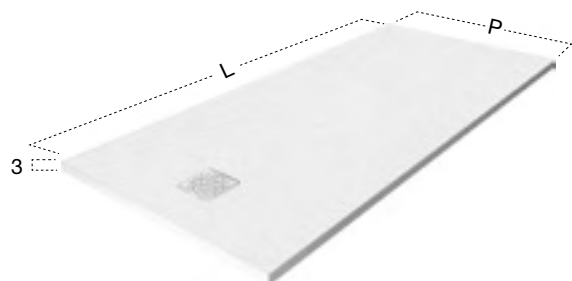

H	L
3	70/80
	80/90
	90/100
	101/110
	111/120
	121/130
	131/140
	141/150
	151/160
	161/170
	171/180
	181/190
	191/200
	201/210
	211/220
	221/230
	231/240
	241/250

## DIMENSIONI A MISURA - CUSTOM MADE MEASUREMENTS

art. **ZEROSTONE\_ML70 / ZEROSTONE\_ML80 / ZEROSTONE\_ML90**

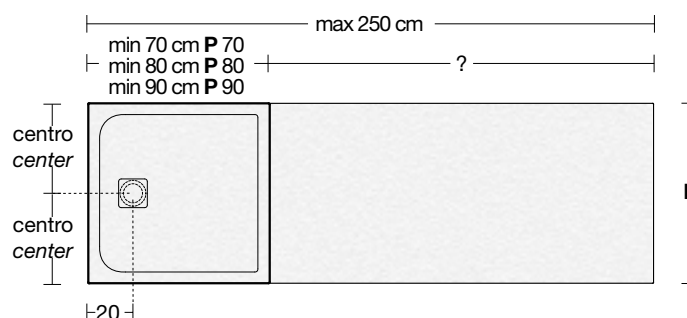

**N.B.** L'invaso con pendenza verso lo scarico, si sviluppa su una lunghezza di 70 cm per Art. **ZEROSTONE\_ML70**, di 80 cm per Art. **ZEROSTONE\_ML80**, di 90 cm per Art. **ZEROSTONE\_ML90**. La parte restante in lunghezza ha una superficie piana.

**P.S.** The slope towards the drain is over a length of 70 cm for the Art. **ZEROSTONE\_ML70**, 80 cm for the Art. **ZEROSTONE\_ML80**, 90 cm for the art. **ZEROSTONE\_ML90**. The remaining part of the tray has a flat surface.

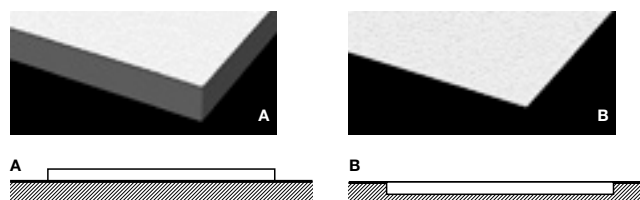

Piatto doccia rettangolare da appoggio **(A)** o da incasso **(B)** in Ceramilux in finitura pietra, completo di sifone e piletta con scarico libero.

*Rectangular top mount **(A)** or encased **(B)** shower tray in Ceramilux in stone finish, complete with siphon and open drain.*

- art. **ZEROSTONE\_MLD180** P 80 L 160/250
- art. **ZEROSTONE\_MLD190** P 90 L 160/250

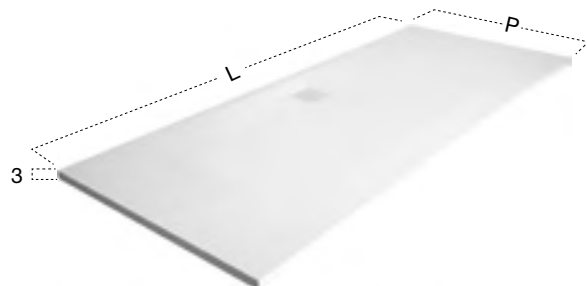

H	L
3	160/170
	171/180
	181/190
	191/200
	201/210
	211/220
	221/230
	231/240
	241/250

## DIMENSIONI A MISURA - CUSTOM MADE MEASUREMENTS

art. **ZEROSTONE\_MLD180 / ZEROSTONE\_MLD190**

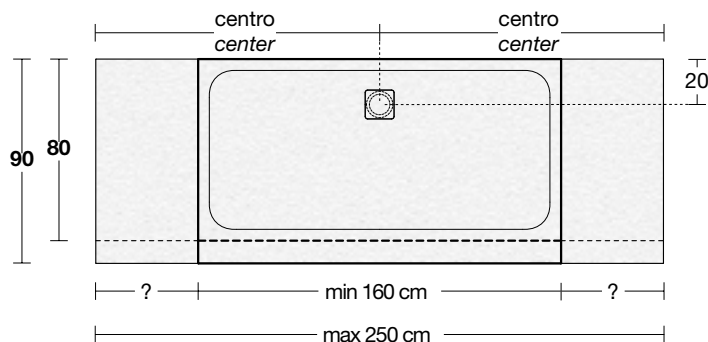

**N.B.** L'invaso con pendenza verso lo scarico, si sviluppa sulla lunghezza di 160 cm e sulla profondità di 80 cm, sia per Art. **ZEROSTONE\_MLD180** che per Art. **ZEROSTONE\_MLD190**. La parte restante in lunghezza ha una superficie piana.

**P.S.** The slope towards the drain is over a length of 160 cm. and over a depth of 80 cm. in Art. **ZEROSTONE\_MLD180** and Art. **ZEROSTONE\_MLD190**. The remaining part of the tray has a flat surface.

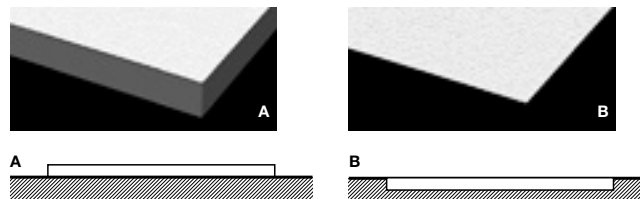

Piatto doccia rettangolare da appoggio **(A)** o da incasso **(B)** in Ceramilux in finitura pietra, completo di sifone e piletta con scarico libero.

*Rectangular top mount **(A)** or encased **(B)** shower tray in Ceramilux in stone finish, complete with siphon and open drain.*

piatti e box doccia  
trays and shower enclosures



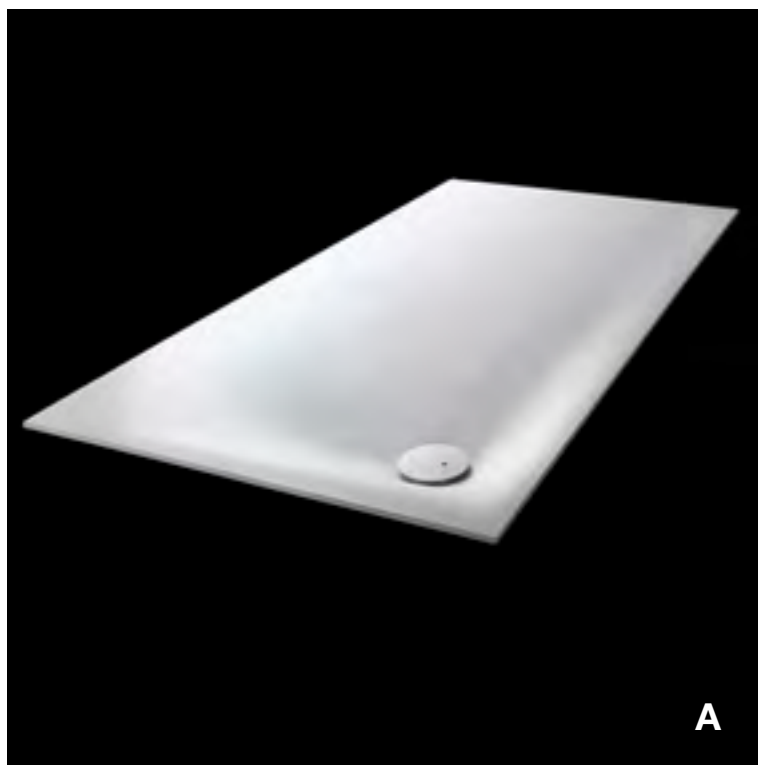

A

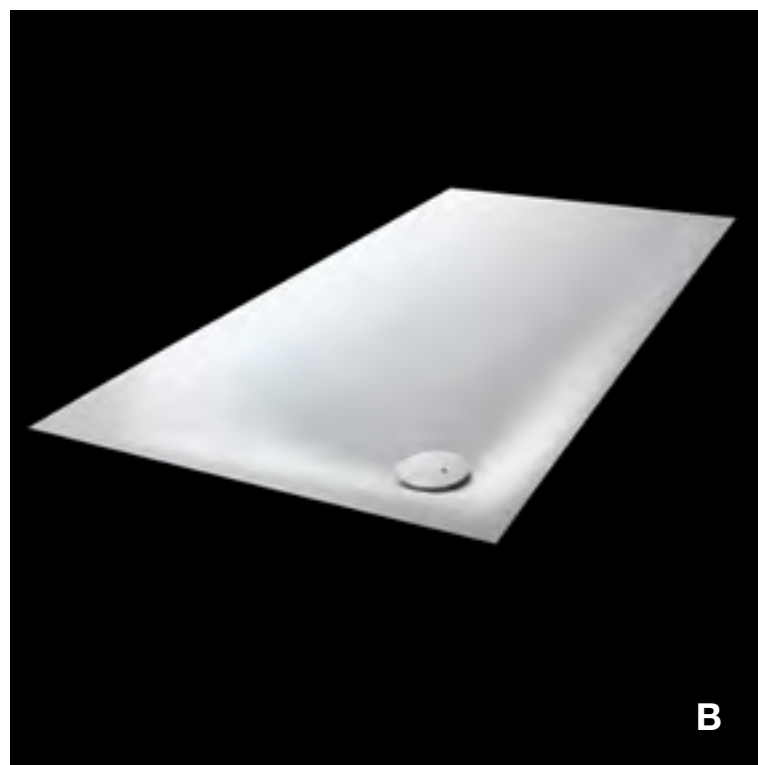

B

art. 00\_ST

DIMENSIONI STANDARD - STANDARD MEASUREMENTS

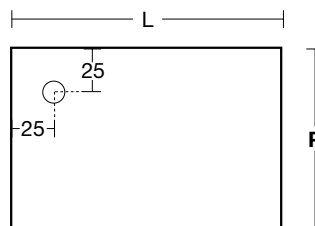
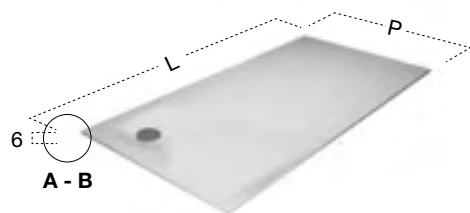

Versione dx - Right version

H	L	P	ART.
6	90	70	00_ST1
	110	80	00_ST2
	120	80	00_ST3
	140	80	00_ST4
	90	90	00_ST5
	140	90	00_ST6

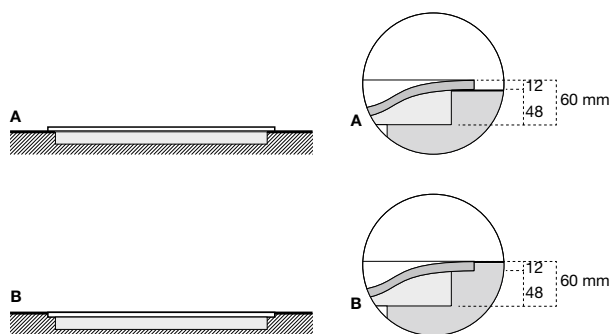

Piatto doccia rettangolare dx o sx da appoggio (A) o da incasso (B) termoformato in Corian, con supporto poliuretano completo di sifone e piletta con scarico libero.

Right or left rectangular top mount (A) or encased (B) shower tray completely in Corian with polyurethane support complete with siphon and open drain.

piatti e box doccia  
trays and shower enclosures







- art. 00\_XL70 P 70
- art. 00\_XL80 P 80
- art. 00\_XL90 P 90
- art. 00\_XL100 P 100
- art. 00\_XL110 P 110
- art. 00\_XL120 P 120
- art. 00\_XL130 P 130
- art. 00\_XL140 P 140

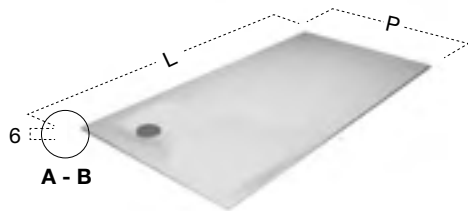

H	L
6	90
	91/100
	101/110
	111/120
	121/130
	131/140
	141/150
	151/160
	161/170
	171/180
	181/190 **
	191/200 **
	201/210 **
	211/220 **
	221/230 **
	231/240 **
	241/250 **
	251/260 **
	261/270 **
	271/280 **
	281/290 **
	291/300 **



**DIMENSIONI A MISURA - CUSTOM MADE MEASUREMENTS**

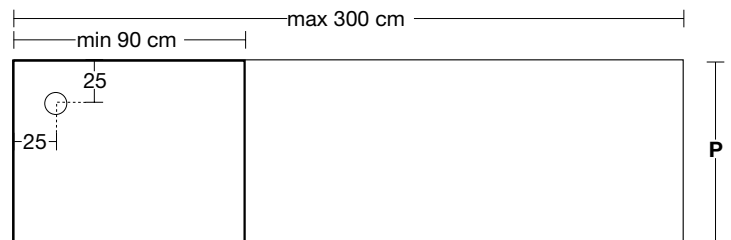

Versione dx - Right version

**\*\* N.B.** Su richiesta è possibile inserire un secondo scarico completo di piletta sifonata. (La pendenza sarà divisa per due).  
**P.S.** Upon request it is possible to have a second drain complete with trap and plug (the slope will be divided in half).

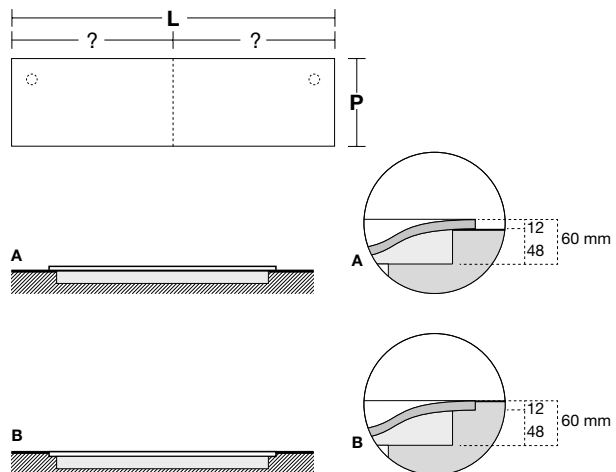

Piatto doccia rettangolare dx o sx a misura, da appoggio (A) o da incasso (B) termoformato in Corian, con supporto poliuretano completo di sifone e piletta con scarico libero.

Right or left rectangular top mount (A) or encased (B) shower tray completely in Corian with polyurethane support complete with siphon and drain.







- art. 00\_COMBI70 P 70
- art. 00\_COMBI80 P 80
- art. 00\_COMBI90 P 90

**N.B.** Per vetri - for shower enclosures

- Art. COMBI20 - Art. COMBI120 - Art. COMBI70 - Art. COMBI80
- Art. COMBI90 - Art. COMBI170 - Art. COMBI180 - Art. COMBI190

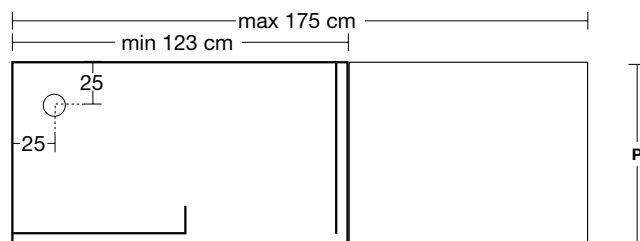
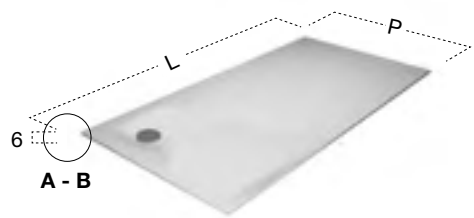

H	L
6	123
	136
	149
	162
	175



Versione dx - Right version

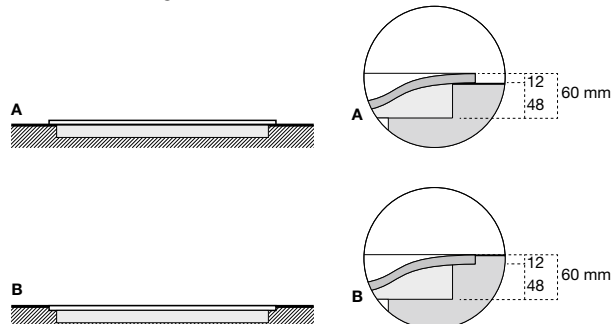

Piatto doccia rettangolare dx o sx da appoggio (A) o da incasso (B) termoformato in Corian, con supporto poliuretano completo di sifone e piletta con scarico libero.

Right or left rectangular top mount (A) or encased (B) shower tray completely in Corian with polyurethane support complete with siphon and open drain.

Modello e design registrato  
Registered model and design

**OXCOMBI**

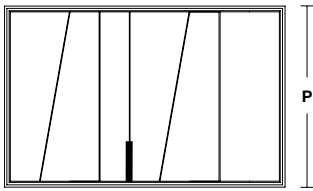

L 121,5 P 78,5 / 88,5  
VERSIONE SX - Left version

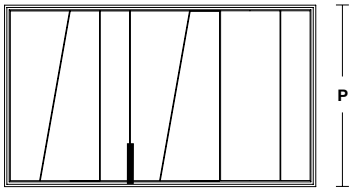

L 134,5 P 78,5 / 88,5  
VERSIONE SX - Left version

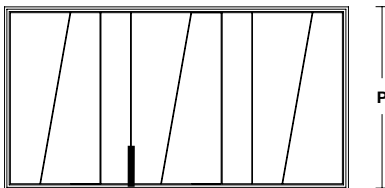

L 147,5 P 78,5 / 88,5  
VERSIONE SX - Left version

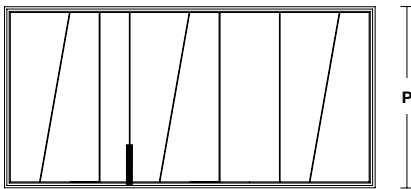

L 160,5 P 78,5 / 88,5  
VERSIONE SX - Left version

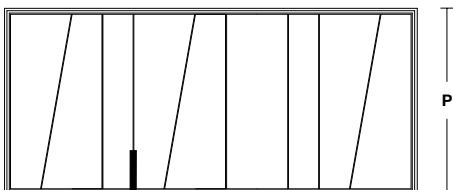

L 173,5 P 78,5 / 88,5  
VERSIONE SX - Left version

**OXCOMBI con rivestimento / with wall covering**

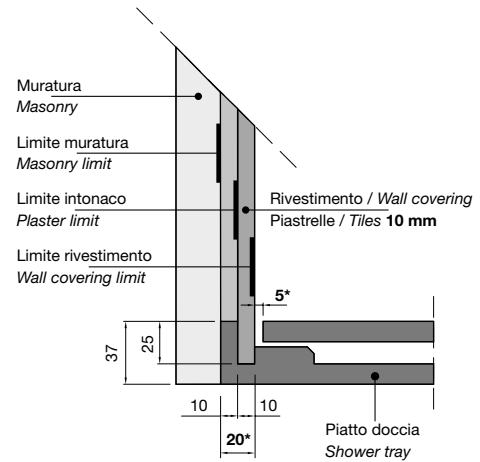

Rivestimento / Wall covering  
**10 mm**

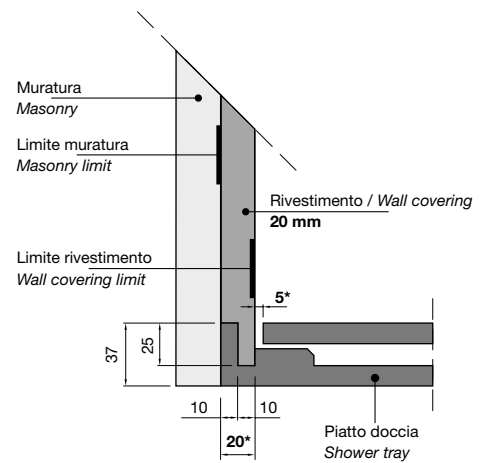

Rivestimento / Wall covering  
**20 mm**

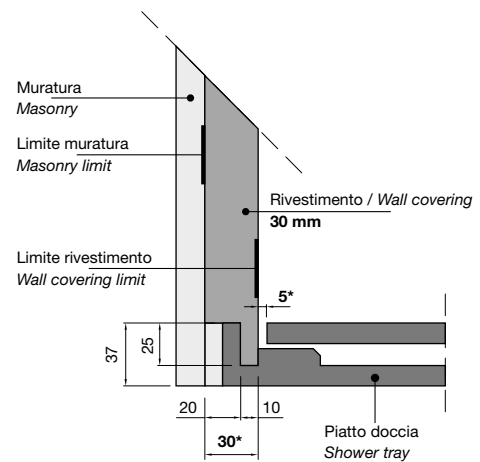

Rivestimento / Wall covering  
**30 mm**

\* Misure Tassative / Strict measurements



piatti e box doccia  
trays and shower enclosures



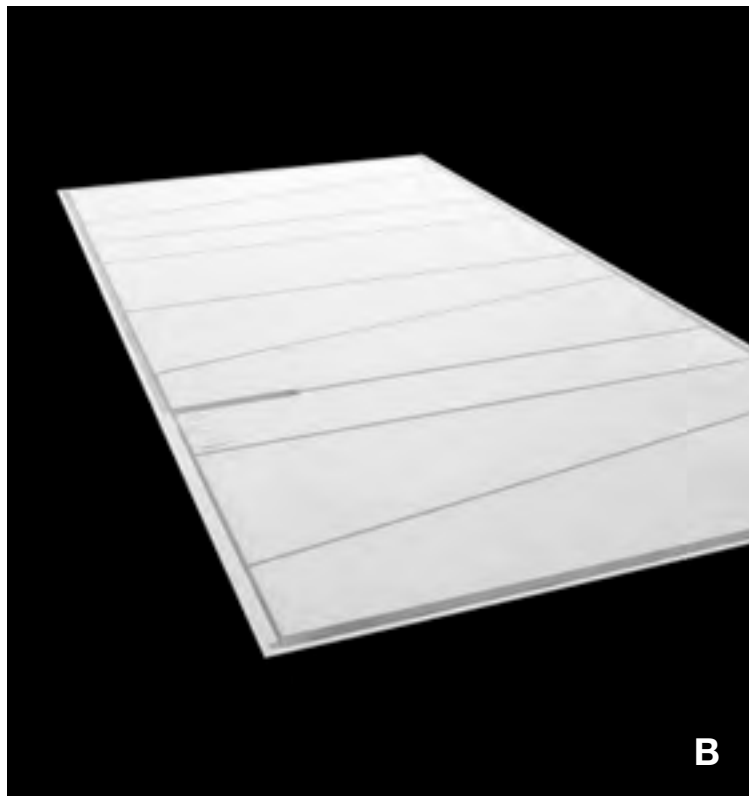
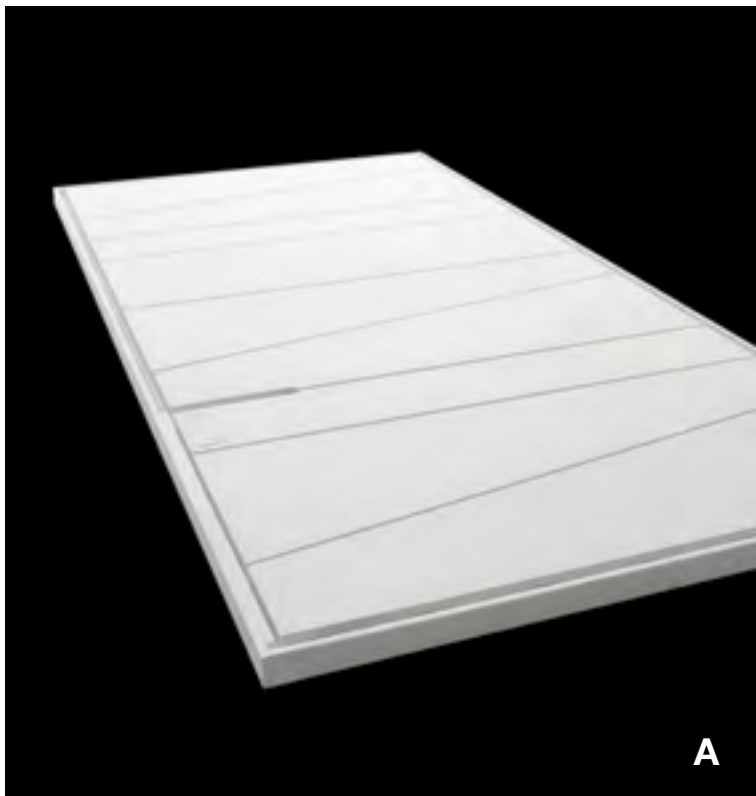

art. **0X78,5COMBI** P 78,5  
 art. **0X88,5COMBI** P 88,5

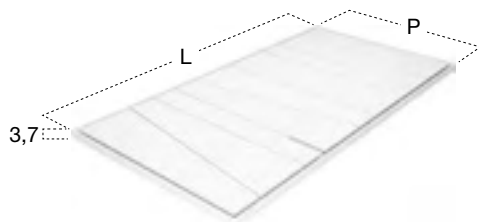

H	L	
3,7	121,5 *	Larghezza : 2 - Length / 2
	134,5 *	Larghezza : 2 - Length / 2
	147,5 *	Larghezza : 2 - Length / 2
	160,5 **	Larghezza : 3 - Length / 3
	173,5 **	Larghezza : 3 - Length / 3

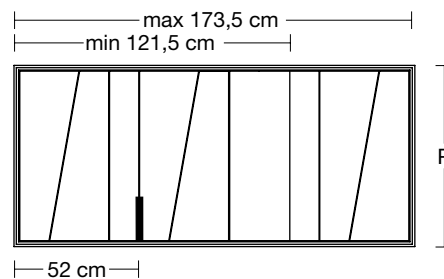

Versione sx - Left version

\* N° 01 Scarico centrale (Larghezza diviso 2)  
 N° 01 Central drain (Length divided by 2)

\*\* N° 02 Scarichi (Larghezza diviso 3)  
 N° 02 Drains (Length divided by 3)

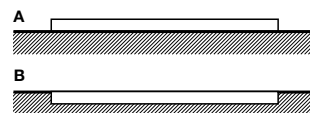

Piatto doccia rettangolare dx o sx da appoggio (A) o da incasso (B) solo per box doccia Art. OXCOMBI, completo di sifone con pedana in Corian composta da doghe dritte e irregolari removibili.

Right or left rectangular top mount (A) or encased (B) Corian shower tray only for shower enclosures Art. OXCOMBI, complete with trap; footboard made of straight and irregular removable slabs.

# OXCOMBI

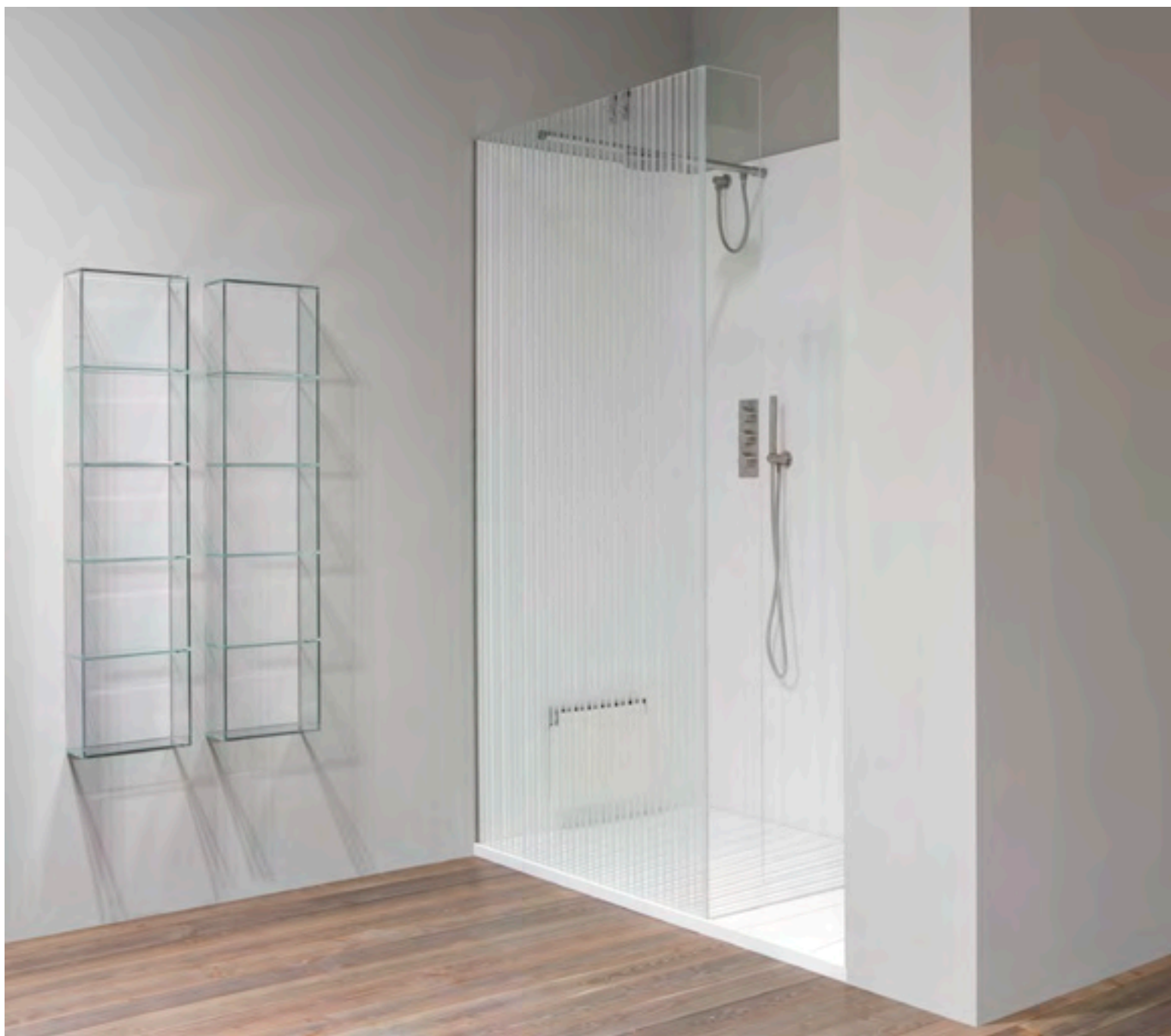

piatti e box doccia  
trays and shower enclosures

art. **OXCOMBI18** H 197,5

art. **OXCOMBI118** H 222,5

Cristallo trasparente    Cristallo extrachiaro    Cristallo acidato    Cristallo bronzo  
*Transparent glass    Extra-clear glass    Acid glass    Bronze glass*

**Per piatti doccia**  
*For shower trays*

P	L	L
18,3	64,6	121,5
	77,6	134,5
	90,6	147,5
	103,6	160,5
	116,6	173,5

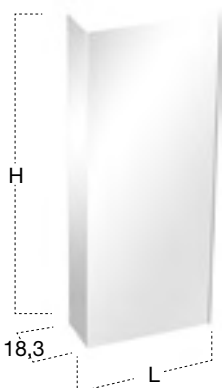

Versione sx - Left version

Box doccia dx o sx in vetro temperato spess. 8 mm solo per piatto doccia Art. OXCOMBI tra pareti in nicchia, completo di profilo a parete.

*Right or left shower enclosure in tempered glass 8 mm thick only for shower trays Art. OXCOMBI, within a recessed area complete with wall profile.*





# OXCOMBI



piatti e box doccia  
trays and shower enclosures

art. **OXCOMBI78** H 197,5 P 78,5  
art. **OXCOMBI88** H 197,5 P 88,5

Cristallo trasparente    Cristallo extrachiaro    Cristallo acidato    Cristallo bronzo  
Transparent glass    Extra-clear glass    Acid glass    Bronze glass

art. **OXCOMBI178** H 222,5 P 78,5  
art. **OXCOMBI188** H 222,5 P 88,5

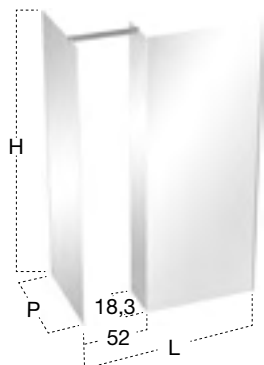

Versione sx - Left version

		Per piatti doccia For shower trays	
P	L	P	L
74,5	117,4	<b>78,5</b>	121,5
	130,4		134,5
	143,4		147,5
	156,4		160,5
	169,4		173,5
84,5	117,4	<b>88,5</b>	121,5
	130,4		134,5
	143,4		147,5
	156,4		160,5
	169,4		173,5

Box doccia dx o sx in vetro temperato spess. 8 mm solo per piatto doccia Art. OXCOMBI tra pareti in angolo, completo di profili a parete e distanziale in acciaio inox satinato AISI 304.

Right or left shower enclosure in tempered glass 8 mm thick only for shower trays Art. OXCOMBI, within a corner complete with wall profiles and stainless steel AISI 304 bar.







piatti e box doccia  
trays and shower enclosures

art. **ISOLA78** P 78,5  
art. **ISOLA88** P 88,5

Cristallo trasparente    Cristallo extrachiaro    Cristallo acidato    Cristallo bronzo  
Transparent glass    Extra-clear glass    Acid glass    Bronze glass

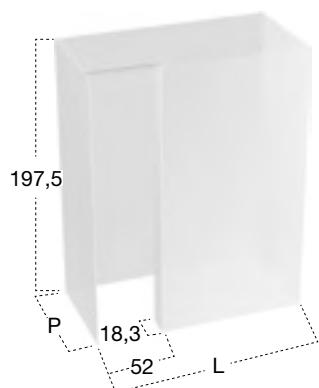

Versione sx - Left version

		Per piatti doccia For shower trays	
P	L	P	L
76,3	119,3	<b>78,5</b>	121,5
	132,3		134,5
	145,3		147,5
	158,3		160,5
	171,3		173,5
86,3	119,3	<b>88,5</b>	121,5
	132,3		134,5
	145,3		147,5
	158,3		160,5
	171,3		173,5

Box doccia dx o sx ad isola in vetro temperato spess. 8 mm solo per piatto doccia Art. 0XCOMBI, completo di distanziale in acciaio inox satinato AISI 304.

Right or left freestanding shower enclosure in tempered glass 8 mm thick only for shower trays Art. 0XCOMBI, complete with satin stainless steel AISI 304 bar.







piatti e box doccia  
trays and shower enclosures

art. **PENISOLA78** P 78,5  
art. **PENISOLA88** P 88,5

Cristallo trasparente    Cristallo extrachiaro    Cristallo acidato    Cristallo bronzo  
Transparent glass    Extra-clear glass    Acid glass    Bronze glass

**Per piatti doccia**  
For shower trays

P	L	P	L
76,3	119,3	<b>78,5</b>	121,5
	132,3		134,5
	145,3		147,5
	158,3		160,5
	171,3		173,5
86,3	119,3	<b>88,5</b>	121,5
	132,3		134,5
	145,3		147,5
	158,3		160,5
	171,3		173,5

Box doccia dx o sx a penisola in vetro temperato spess. 8 mm solo per piatto doccia Art. OXCOMBI, completo di profili a parete e distanziale in acciaio inox satinato AISI 304.

Right or left shower enclosure in tempered glass 8 mm thick only for shower trays Art. OXCOMBI, complete with wall profiles and satin stainless steel AISI 304 bar.

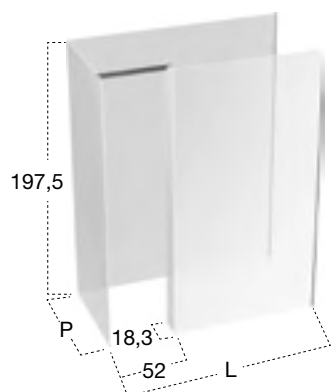

Versione sx - Left version





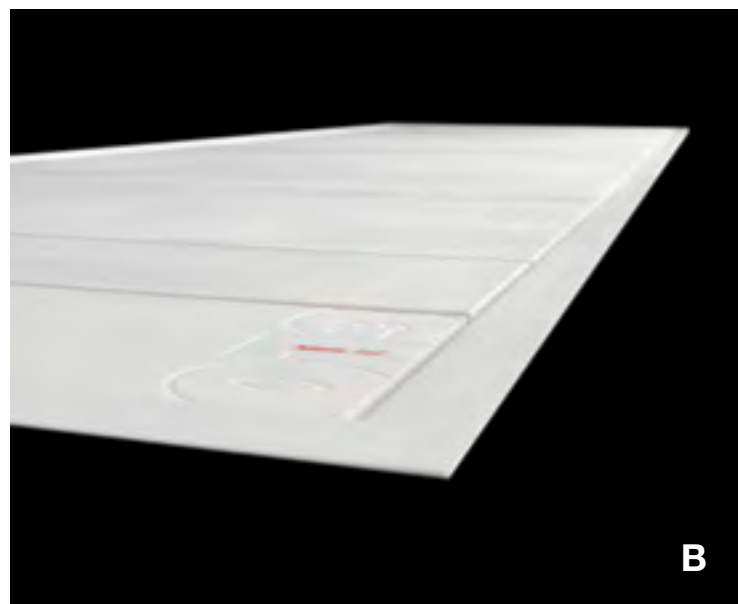

art. 01370 P 70  
 art. 01380 P 80  
 art. 01390 P 90

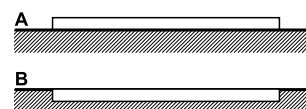
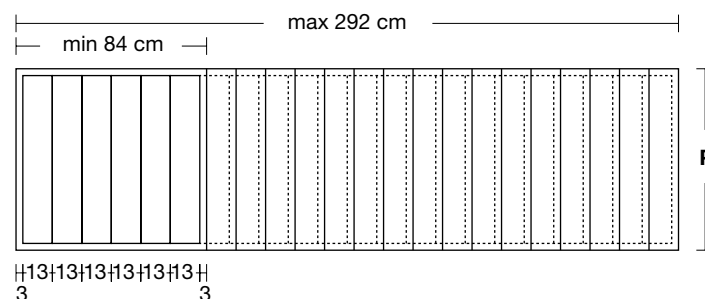

H	L	
3,9	84	* Larghezza: 2 - Length / 2
	97	* Larghezza: 2 - Length / 2
	110	* Larghezza: 2 - Length / 2
	123	* Larghezza: 2 - Length / 2
	136	* Larghezza: 2 - Length / 2
	149	* Larghezza: 2 - Length / 2
	162	** Larghezza: 3 - Length / 3
	175	** Larghezza: 3 - Length / 3
	188	** Larghezza: 3 - Length / 3
	201	** Larghezza: 3 - Length / 3
	214	** Larghezza: 3 - Length / 3
	227	** Larghezza: 3 - Length / 3
	240	** Larghezza: 3 - Length / 3
	253	** Larghezza: 3 - Length / 3
	266	** Larghezza: 3 - Length / 3
	279	** Larghezza: 3 - Length / 3
	292	** Larghezza: 3 - Length / 3

\* N° 01 Scarico centrale (Larghezza diviso 2)  
 N° 01 Central drain (Length divided by 2)

\*\* N° 02 Scarichi (Larghezza diviso 3)  
 N° 02 Drains (Length divided by 3)



Piatto doccia rettangolare da appoggio (A) o da incasso (B) in Corian con pedana composta da doghe L 13 cm removibili, completo di sifone.

Rectangular top mount (A) or encased (B) Corian shower tray complete with siphon; footboard made of removable slabs 13 cm L.

piatti e box doccia  
trays and shower enclosures



**013COMBI** design Nevio Tellatin



Versione sx - *Left version*

- art. **01370COMBI** P 70
- art. **01380COMBI** P 80
- art. **01390COMBI** P 90



Versione dx - *Right version*

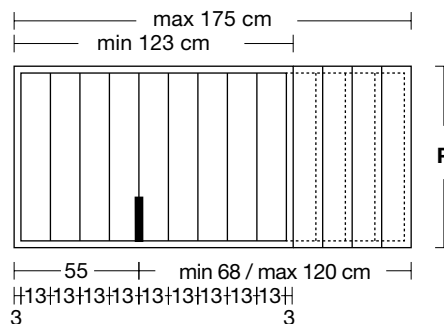

piatti e box doccia  
trays and shower enclosures

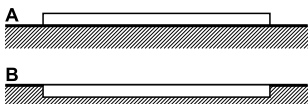

H	L	
3,9	123	* Larghezza : 2 - Length / 2
	136	* Larghezza : 2 - Length / 2
	149	* Larghezza : 2 - Length / 2
	162	** Larghezza : 3 - Length / 3
	175	** Larghezza : 3 - Length / 3

\* N° 01 Scarico centrale (Larghezza diviso 2)  
N° 01 Central drain (Length divided by 2)

\*\* N° 02 Scarichi (Larghezza diviso 3)  
N° 02 Drains (Length divided by 3)

Piatto doccia rettangolare dx o sx da appoggio (A) o da incasso (B) in Corian con pedana composta da doghe L 13 cm removibili, completo di sifone.

Right or left rectangular top mount (A) or encased (B) Corian shower tray complete with siphon; footboard made of removable slabs 13 cm L.





cristallo extrachiaro  
*extra-clear glass*

---



cristallo trasparente  
*transparent glass*

---



cristallo acidato  
*acid glass*

---



cristallo bronzo  
*bronze glass*

---



piatti e box doccia  
trays and shower enclosures

Cristallo trasparente    Cristallo extrachiario    Cristallo acidato    Cristallo bronzo  
Transparent glass    Extra-clear glass    Acid glass    Bronze glass

H	L	ART.
195	77,5	<b>VB13</b>
	87,5	<b>VB14</b>
	97,5	<b>VB15</b>
	107,5	<b>VB16</b>
	117,5	<b>VB17</b>
	127,5	<b>VB18</b>
220	137,5	<b>VB19</b>
	77,5	<b>VB3</b>
	87,5	<b>VB4</b>
	97,5	<b>VB5</b>
	107,5	<b>VB6</b>
	117,5	<b>VB7</b>
	127,5	<b>VB8</b>
	137,5	<b>VB9</b>

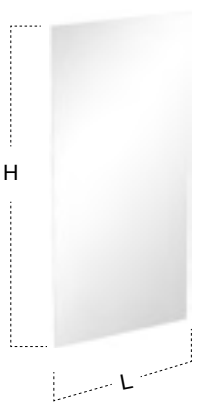

Vetro temperato spess. 8 mm solo per piatti doccia Art. 00\_XL, Art. 00\_ST, Art. 013, Art. ZEROLUX\_ST, Art. ZEROLUX\_XL, Art. ZEROMATT\_ST, Art. ZEROMATT\_ML e Art. ZEROSTONE\_ML.

8 mm tempered glass only for shower trays Art. 00\_XL, Art. 00\_ST, Art. 013, Art. ZEROLUX\_ST, Art. ZEROLUX\_XL, Art. ZEROMATT\_ST, Art. ZEROMATT\_ML and Art. ZEROSTONE\_ML.



art. **COMBI20** H 195  
 art. **COMBI120** H 220

Cristallo trasparente    Cristallo extrachiaro    Cristallo acidato    Cristallo bronzo  
*Transparent glass    Extra-clear glass    Acid glass    Bronze glass*

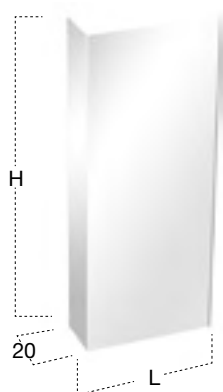

Versione sx - Left version

Per piatti doccia For shower trays		
P	L	L
20	66	123
	79	136
	92	149
	105	162
	118	175

Box doccia dx o sx in vetro temperato spess. 8 mm solo per piatti doccia Art. 00\_COMBI e Art. 013COMBI tra pareti in nicchia, completo di profilo a parete.

*Right or left shower enclosure in 8 mm tempered glass only for shower trays Art. 00\_COMBI and Art. 013COMBI within a recessed area complete with wall profiles.*



# COMBI



piatti e box doccia  
trays and shower enclosures

- art. **COMBI70**    H 195    P 70
- art. **COMBI80**    H 195    P 80
- art. **COMBI90**    H 195    P 90

- art. **COMBI170**    H 220    P 70
- art. **COMBI180**    H 220    P 80
- art. **COMBI190**    H 220    P 90

- Cristallo trasparente  
*Transparent glass*
- Cristallo extrachiaro  
*Extra-clear glass*
- Cristallo acidato  
*Acid glass*
- Cristallo bronzo  
*Bronze glass*

**Per piatti doccia**  
*For shower trays*

P	L	P	L
67,5	120,5	<b>70</b>	123
	133,5		136
	146,5		149
	159,5		162
	172,5		175
77,5	120,5	<b>80</b>	123
	133,5		136
	146,5		149
	159,5		162
	172,5		175
87,5	120,5	<b>90</b>	123
	133,5		136
	146,5		149
	159,5		162
	172,5		175

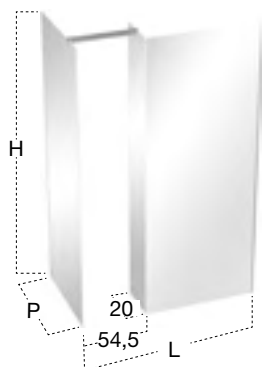

Versione sx - Left version

Box doccia dx o sx in vetro temperato spess. 8 mm solo per piatti doccia Art. 013COMBI e Art. 00\_COMBI tra pareti in angolo, completo di profili a parete e distanziale in acciaio inox satinato AISI 304.

*Right or left shower enclosure in 8 mm tempered glass only for shower trays Art. 013COMBI and Art. 00\_COMBI within a corner complete with wall profile and satin stainless steel AISI 304 bar.*



## POLE design AL Studio

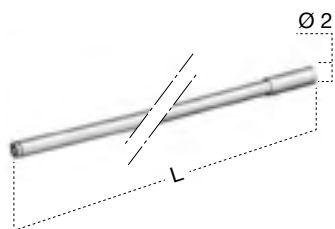

Ø	L	ART.	Per piatti doccia
			For shower trays
			P
2	64,4	<b>POLE1</b>	70
	74,4	<b>POLE2</b>	78,5 / 80
	84,4	<b>POLE3</b>	88,5 / 90
	94,4	<b>POLE4</b>	100
	104,4	<b>POLE5</b>	110

Asta distanziale per vetri box doccia in acciaio inox satinato AISI 304.

*Satin stainless steel AISI 304 shower bar for glass shower.*

## MIX design AL Studio

**Modello e design registrato**  
Registered model and design

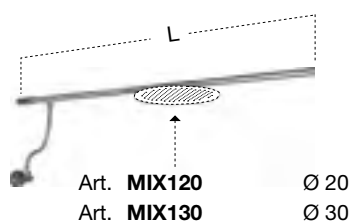

L	ART.	Per piatti doccia
		For shower trays
		P
64,4	<b>MIX70</b>	70
74,4	<b>MIX80</b>	78,5 / 80
84,4	<b>MIX90</b>	88,5 / 90
94,4	<b>MIX100</b>	100
104,4	<b>MIX110</b>	110

Asta distanziale in acciaio inox satinato AISI 304 per vetri box doccia completo di presa a parete con flessibile 60 cm, predisposta per soffione Art. MIX120 - MIX130.

*Satin stainless steel AISI 304 shower bar for glass shower enclosure complete with wall connector and flexible hose 60 cm, prepared for overhead shower Art. MIX120 - MIX130.*

## MIX

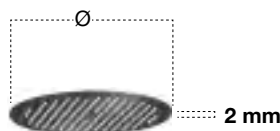

Ø	ART.
20	<b>MIX120</b>
30	<b>MIX130</b>

Soffione ultrasottile 2 mm in acciaio inox satinato AISI 304, con ugelli anticalcare intercambiabili in silicone, predisposto per asta distanziale per vetri box doccia e braccio a soffitto Art. MIX.

*Ultra-thin overhead shower in satin stainless steel AISI 304, with replaceable silicon nozzles resistant to limescale, prepared for use with glass shower cabin bar and ceiling hanging bar Art. MIX.*

## PEG design AL Studio

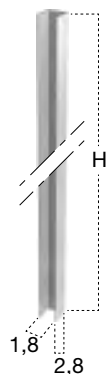

H	P	L	ART.
195	2,8	1,8	<b>PEG4</b>
200	2,8	1,8	<b>PEG3</b>

Profilo in acciaio inox satinato AISI 304 per il fissaggio a parete dei vetri box doccia Art. VB.

*Glass wall fixing profiles in satin stainless steel AISI 304 for shower glass Art. VB.*



I vetri utilizzati nei box doccia, in cristallo trasparente, cristallo extrachiaro o cristallo bronzo, possono essere realizzati esternamente con decori in Duroglass. Alcuni possono avere motivi in positivo, codificato art..../P o in negativo, codificato art..../N.

**Per calcolare il prezzo finale di un vetro bisogna sommare al prezzo della misura e finitura desiderata, il costo per la realizzazione del motivo, moltiplicato per il numero dei vetri decorati.**

*The different glass used for the shower enclosures, clear, extra-clear or bronze, can be decorated on the external side with Duroglass motifs. Some of these can be in positive with art. code /P or in negative with art. code /N.*

**To calculate the final price of a shower glass you must add to the price of the glass in the desired measure and finish the cost of the motif multiplied by the number of glasses to be decorated.**

esempio / example



art. SHAKESPEARE/P



art. SHAKESPEARE/N

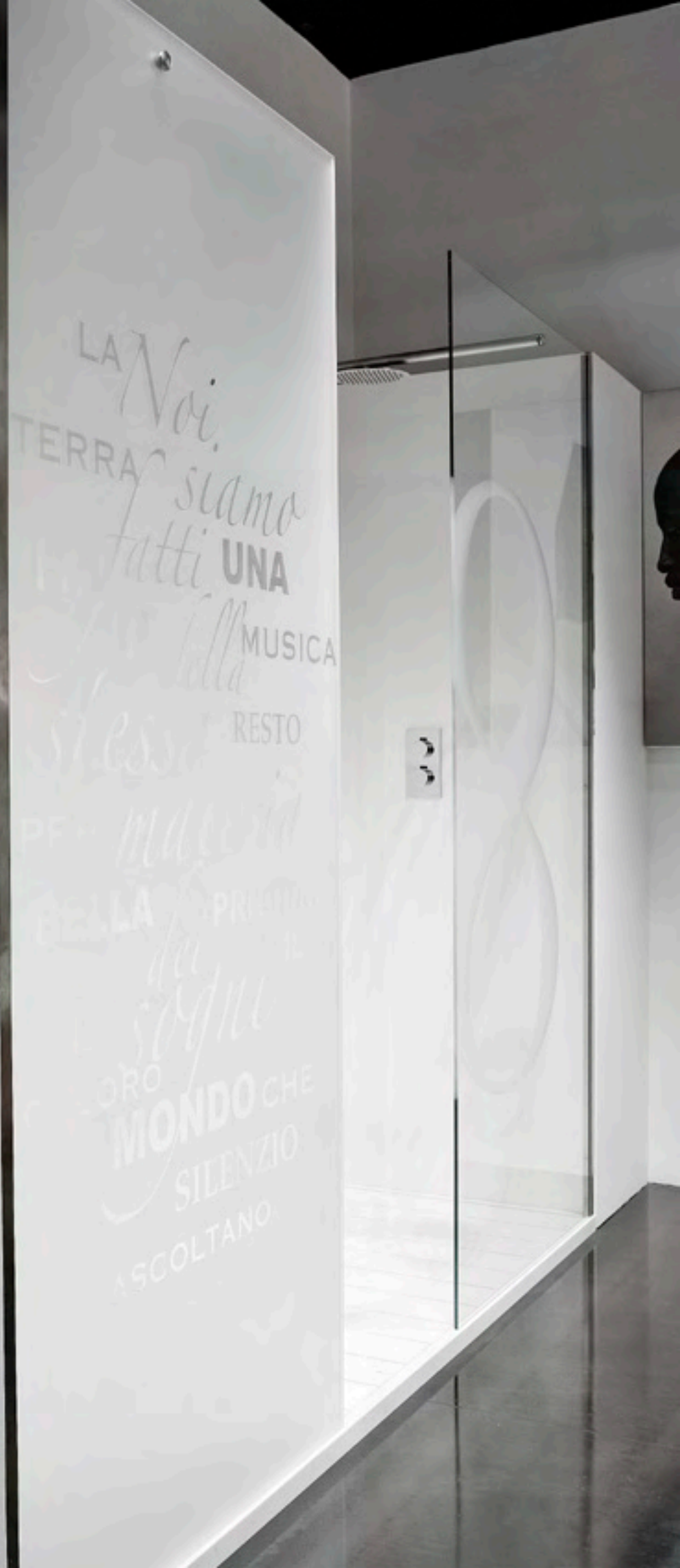

PITAGORA/P numero/*number 8* design Riccardo Fattori

deco positivo/*positive motif*

1 2 3 4  
5 6 7 8  
9 0

deco negativo/*negative motif*

1 2 3 4  
5 6 7 8  
9 0

piatti e box doccia  
trays and shower enclosures

**LABELLEZZA/N** design Riccardo Fattori





decore positivo/positive motif

A B C D  
E F G H  
I J K L  
M N O P  
Q R S T  
U V W X  
Y Z

decore negativo/negative motif

A B C D  
E F G H  
I J K L  
M N O P  
Q R S T  
U V W X  
Y Z

piatti e box doccia  
trays and shower enclosures





piatti e box doccia  
trays and shower enclosures







art. OPERA/P

art. OPERA/N

piatti e box doccia  
trays and shower enclosures

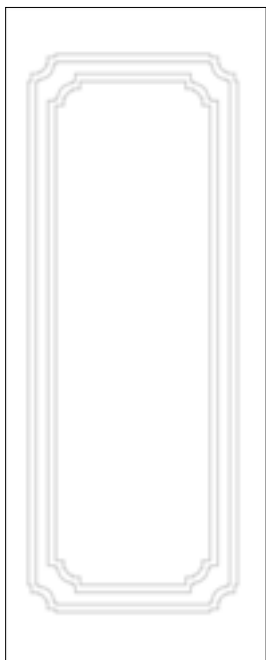

Questi disegni verranno adattati alla dimensione del vetro sia in larghezza che in altezza.

*These designs will be adapted to the measurement of the glass in height and width.*

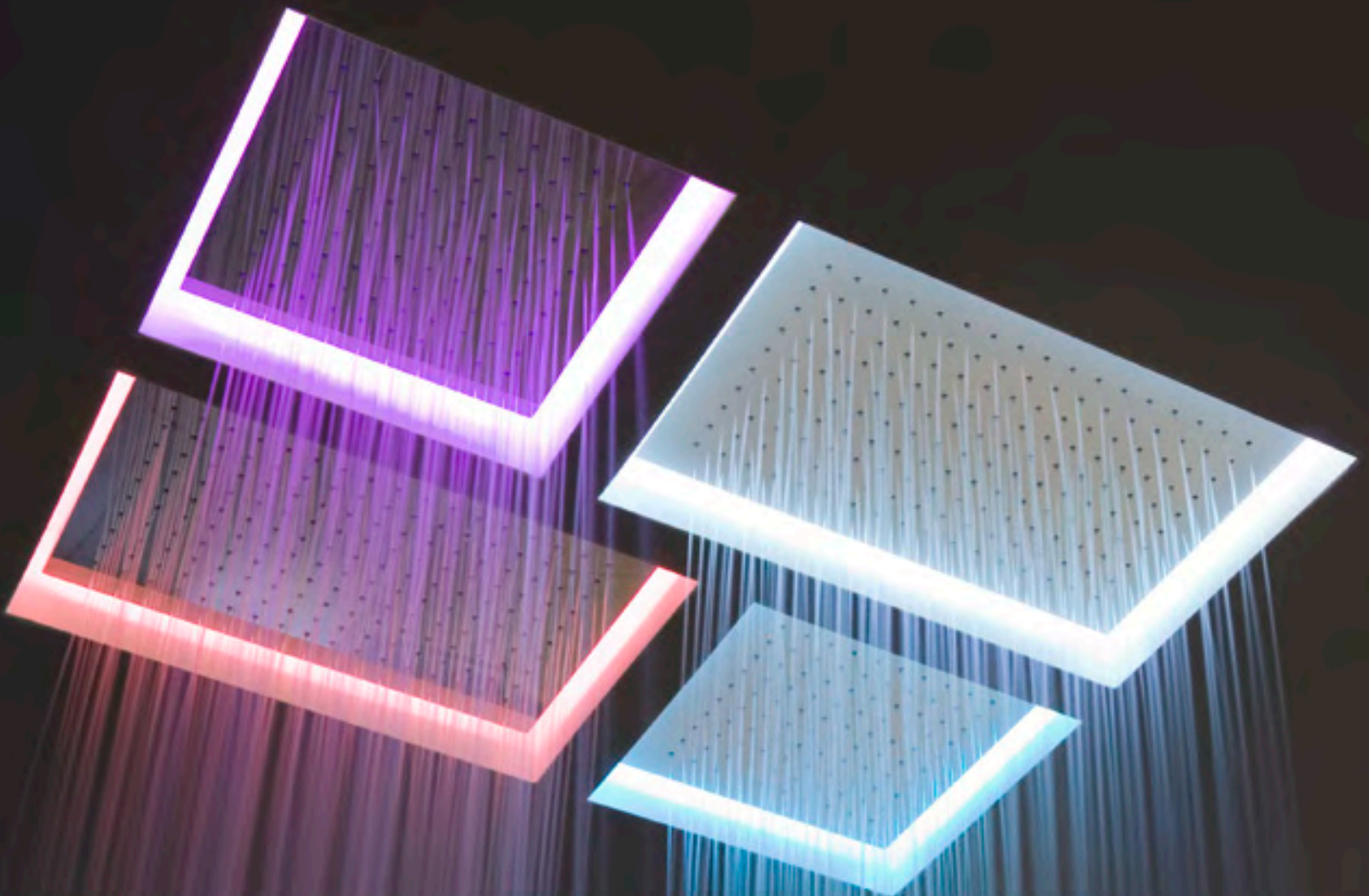



**SOFFIONI E RUBINETTERIA  
OVERHEAD SHOWERS AND TAPS**



soffioni e rubinetteria  
overhead showers and taps

**METEOXXL** design Nevio Tellatin

Modello e design registrato  
*Registered model and design*

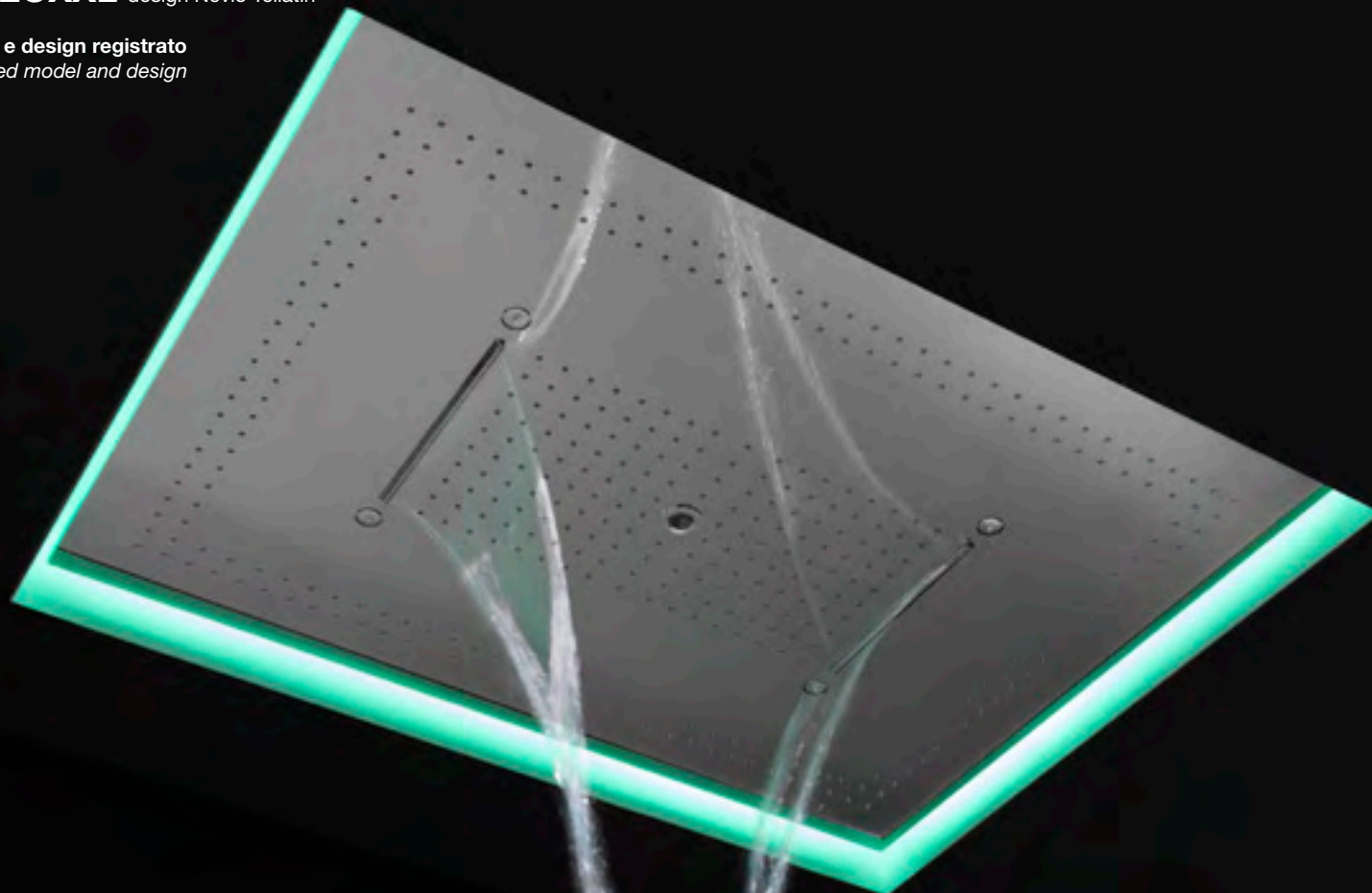

cascata  
*waterfall*



doccia perimetrale  
*perimeter shower*



doccia centrale  
*central shower*



chiodo  
*jet*



nebulizzatori  
*nebulizer*



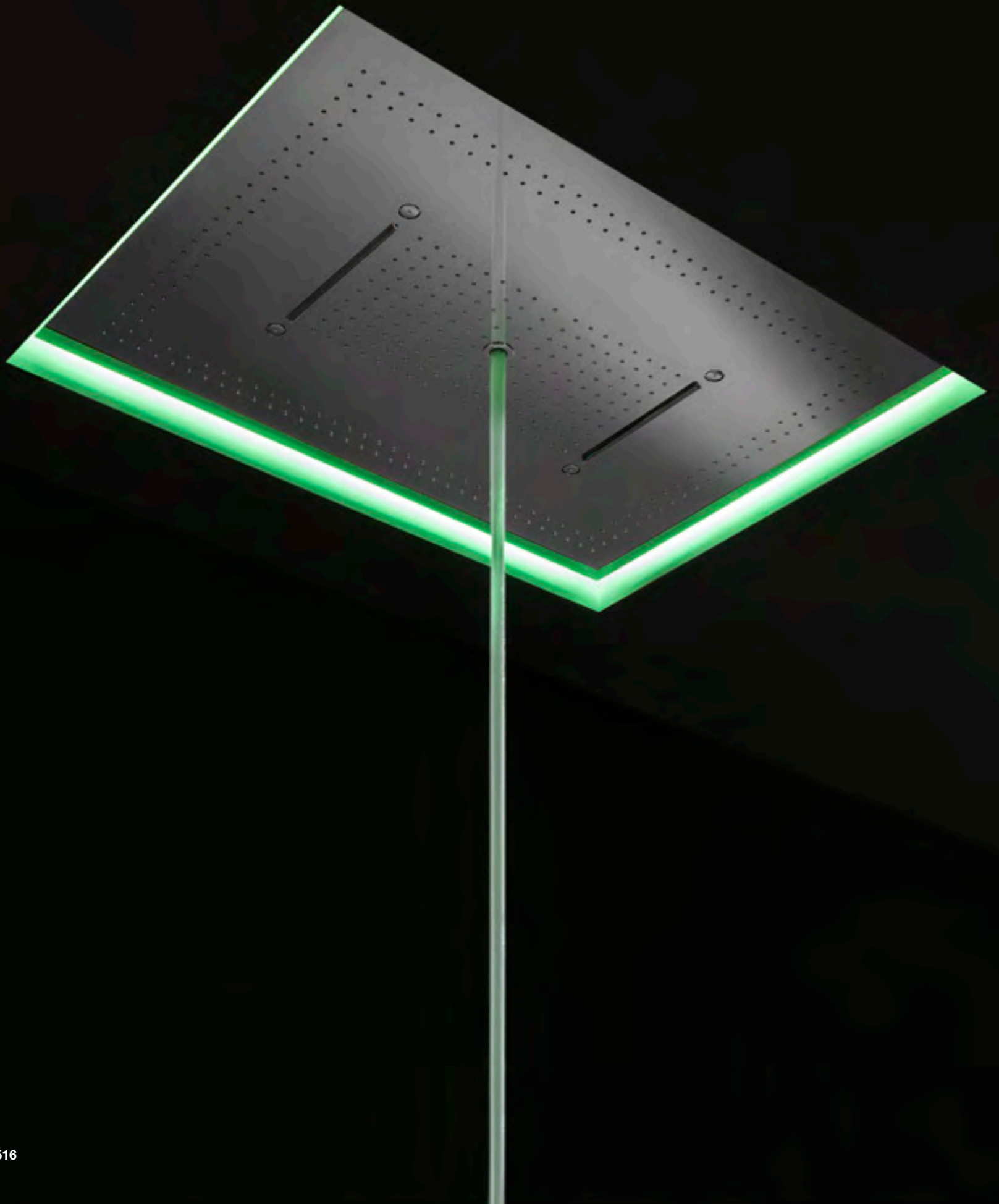

# METEOXXL

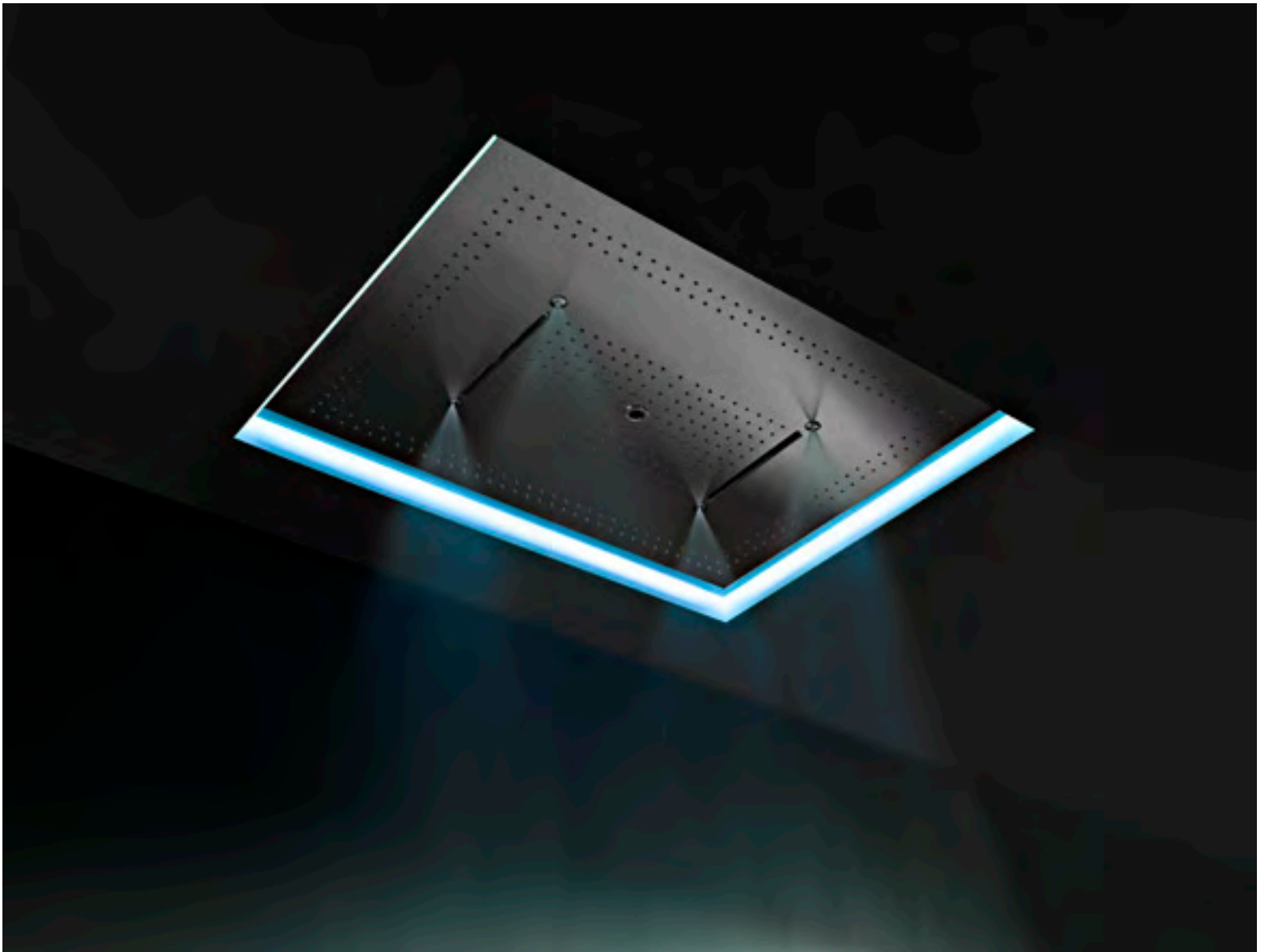

art. METEOXXL L 100 P 75 H 11 cm

soffioni e rubinetteria  
overhead showers and taps

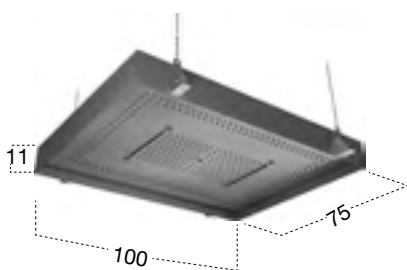

Soffione ad incasso in acciaio AISI 304 con doppia cascata, getto a chiodo e nebulizzatori, con possibile illuminazione a led rgb comprensivo di telecomando.

**N.B.** Necessita di deviatore a cinque vie.

*Encased showerhead in stainless steel AISI 304 with double waterfall, hard center jet and nebulizers, with possible led rgb lighting complete with remote.*

**P.S.** Requires five way diverter.





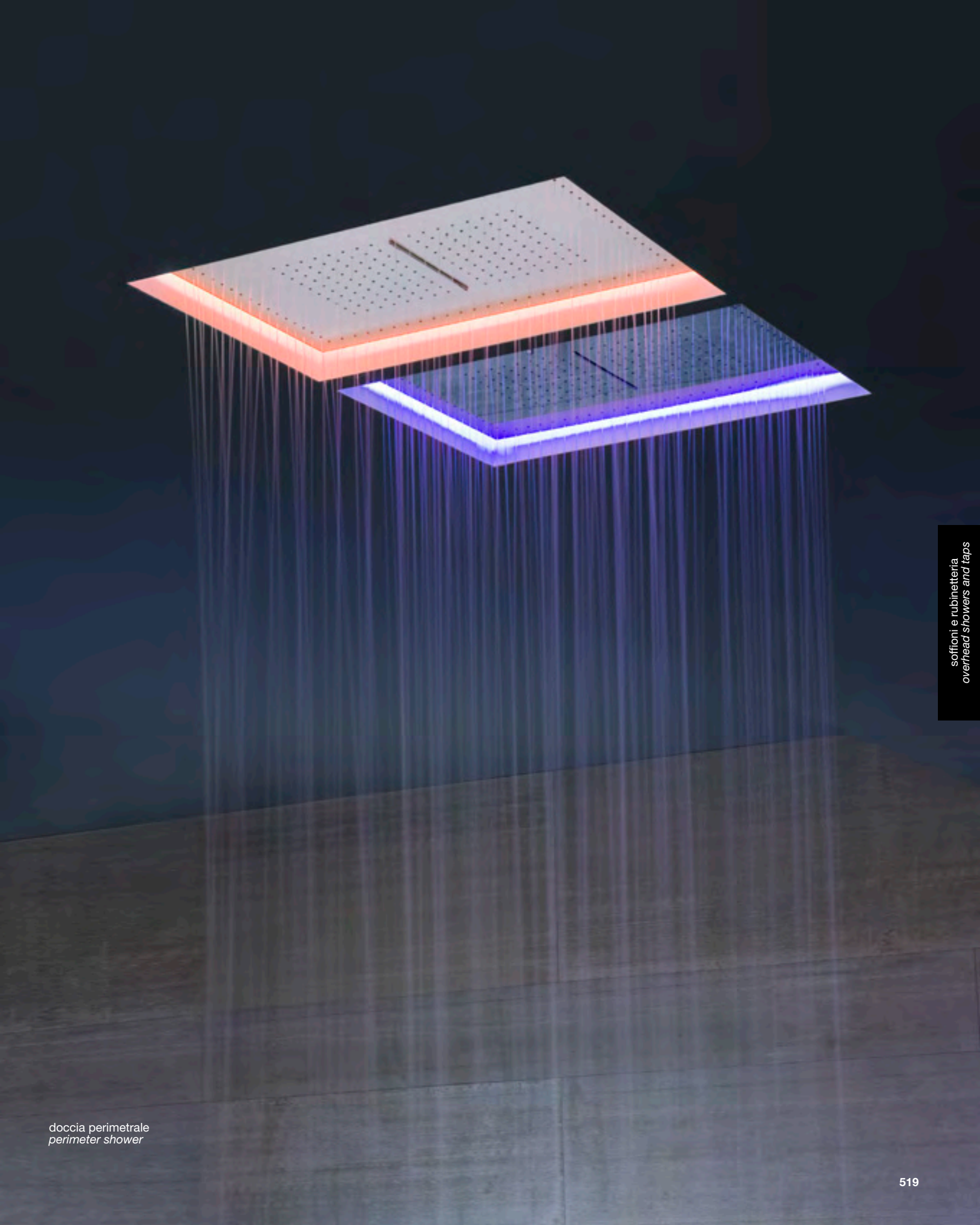

doccia perimetrale  
*perimeter shower*

soffioni e rubinetteria  
*overhead showers and taps*

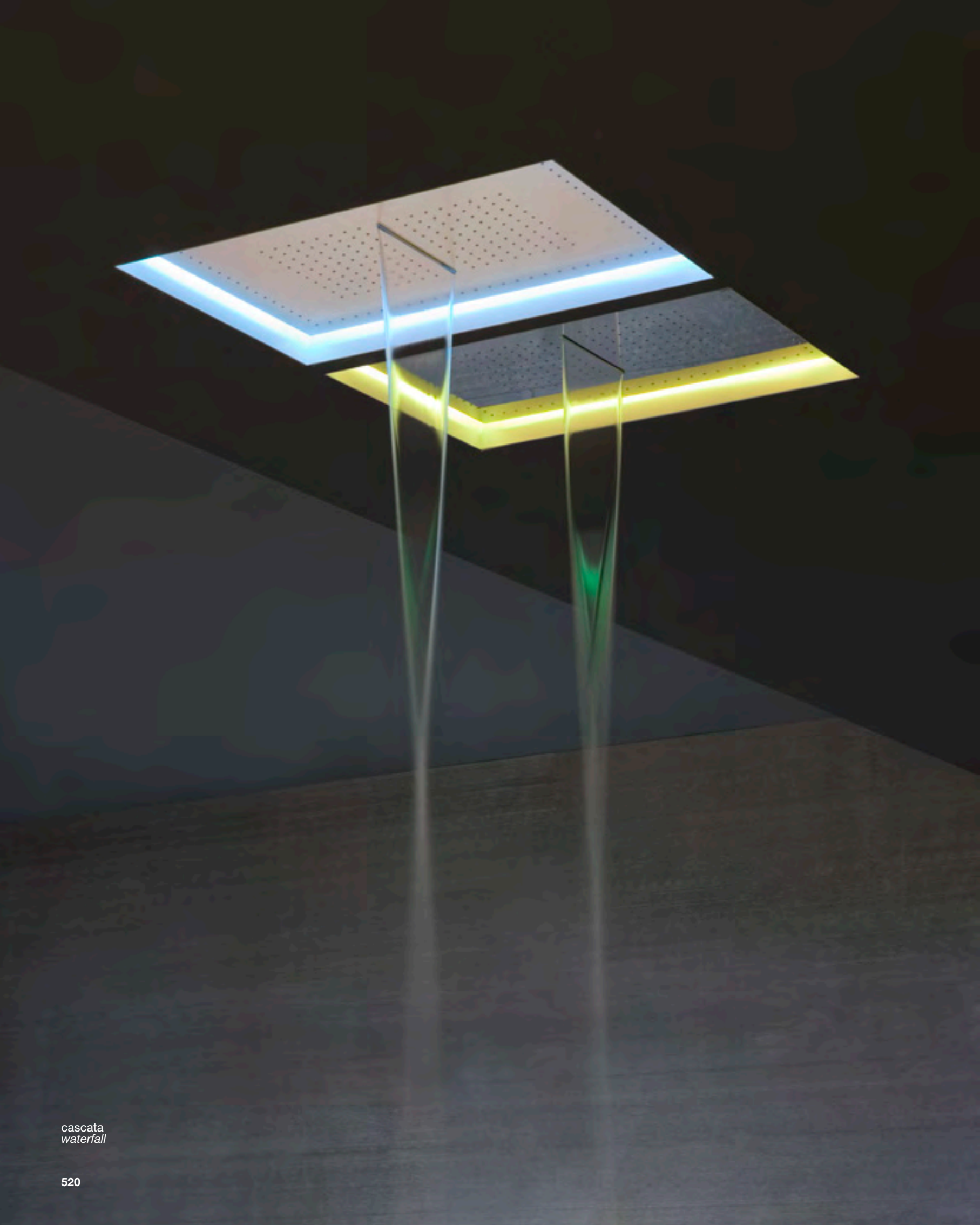

*cascata  
waterfall*

# METEO

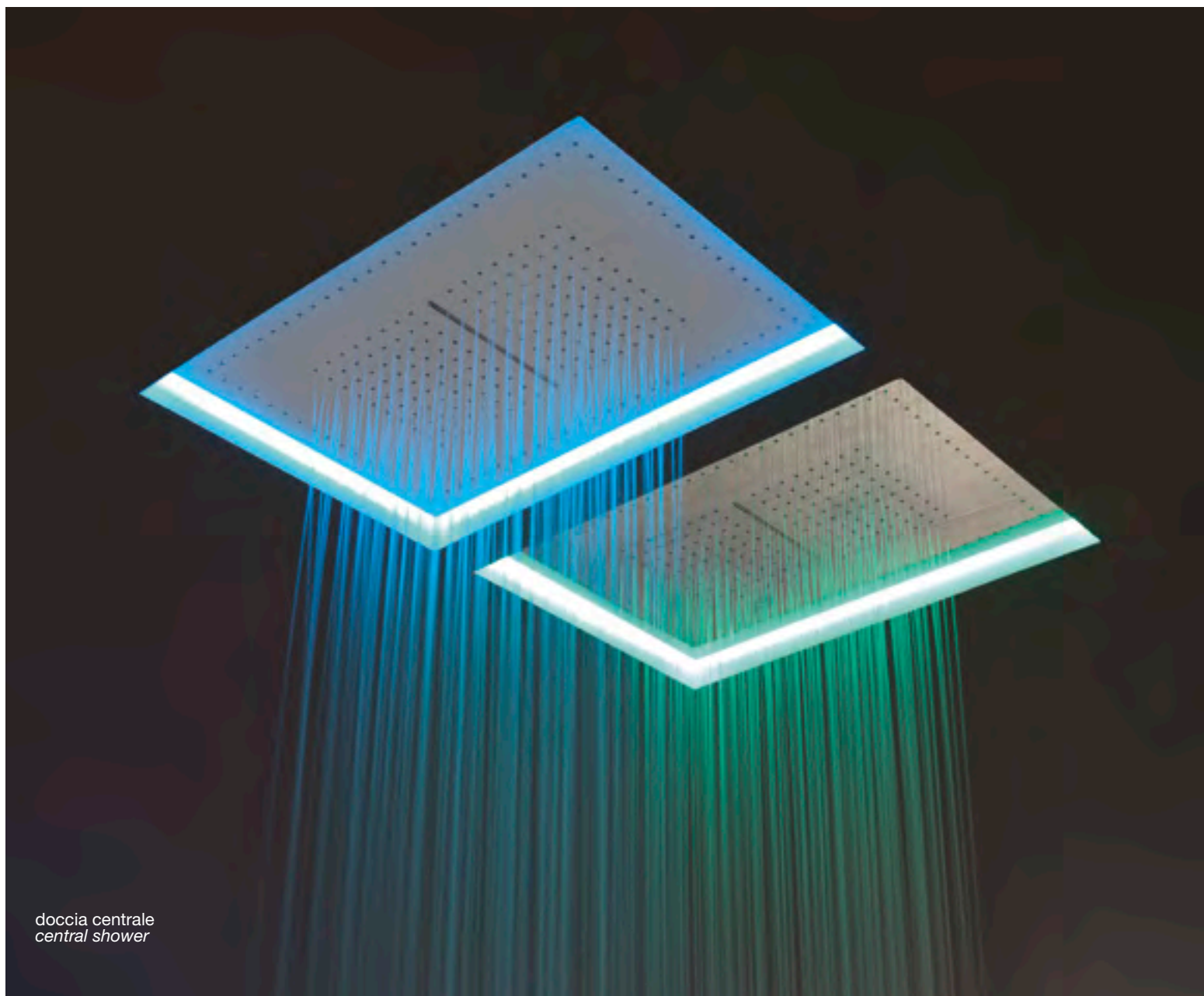

art. METEO3C L 75 P 52 H 11 cm

soffioni e rubinetteria  
overhead showers and taps

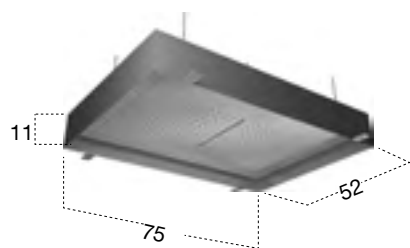

Soffione ad incasso in acciaio AISI 304 con cascata, con possibile illuminazione a led rgb comprensivo di telecomando.

**N.B.** Necessita di deviatore a tre vie.

*Encased showerhead in stainless steel AISI 304 with waterfall with possible rgb led lighting and remote.  
P.S. Requires three way diverter.*



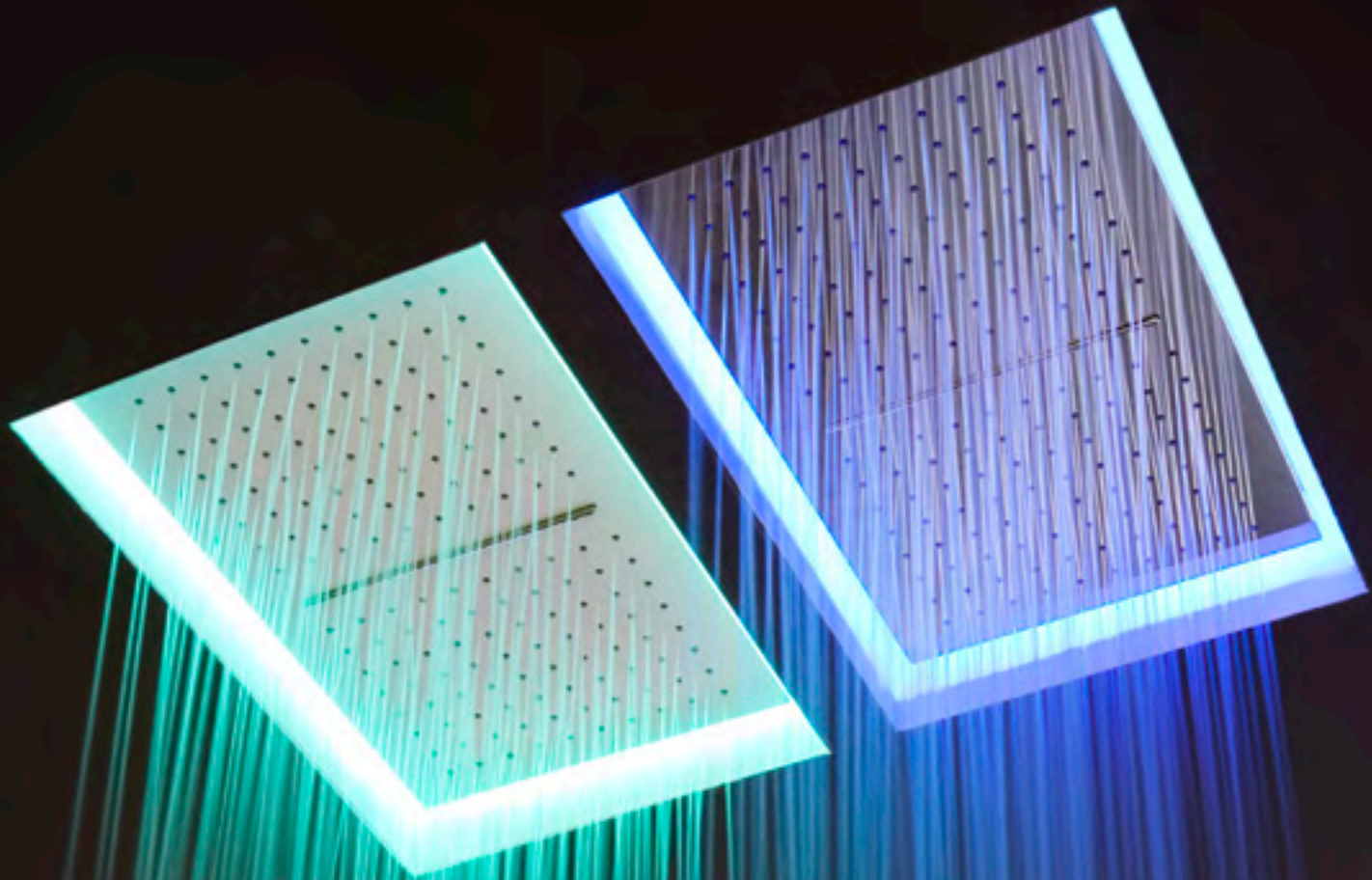

# METEO

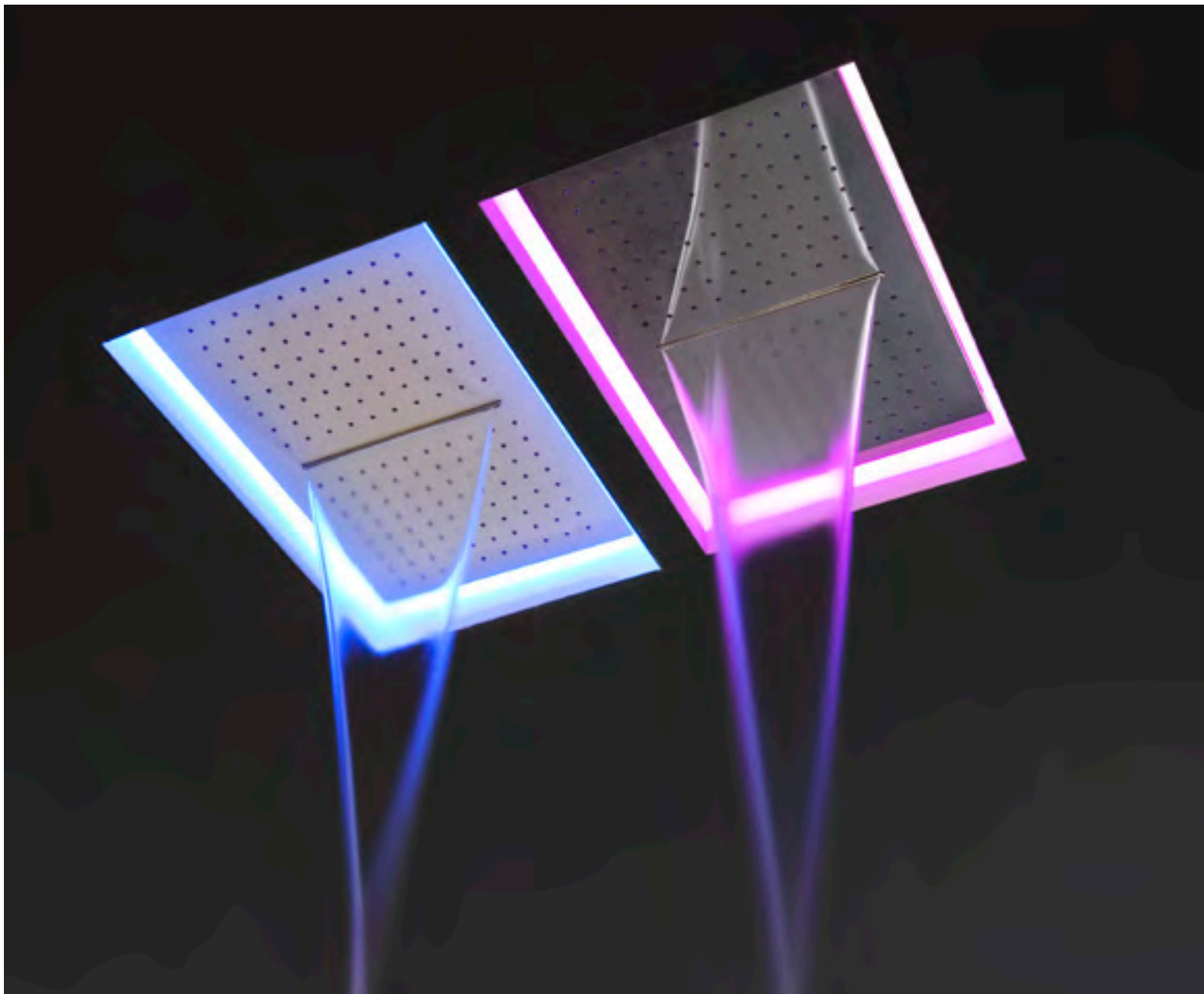

art. METEO2C L 52 P 35 H 11 cm

soffioni e rubinetteria  
overhead showers and taps

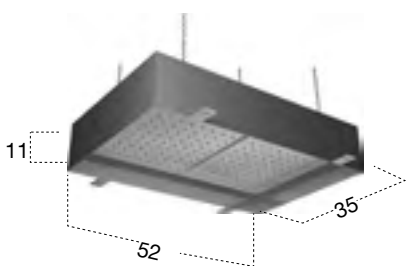

Soffione ad incasso in acciaio AISI 304 con cascata, disponibile in diverse finiture, con possibile illuminazione a led rgb comprensivo di telecomando.  
**N.B.** Necessita di deviatore a due vie.

*Encased waterfall showerhead in stainless steel AISI 304, available in various finishes, with possible rgb led lighting and remote.  
**P.S.** Requires two way diverter.*





# METEO

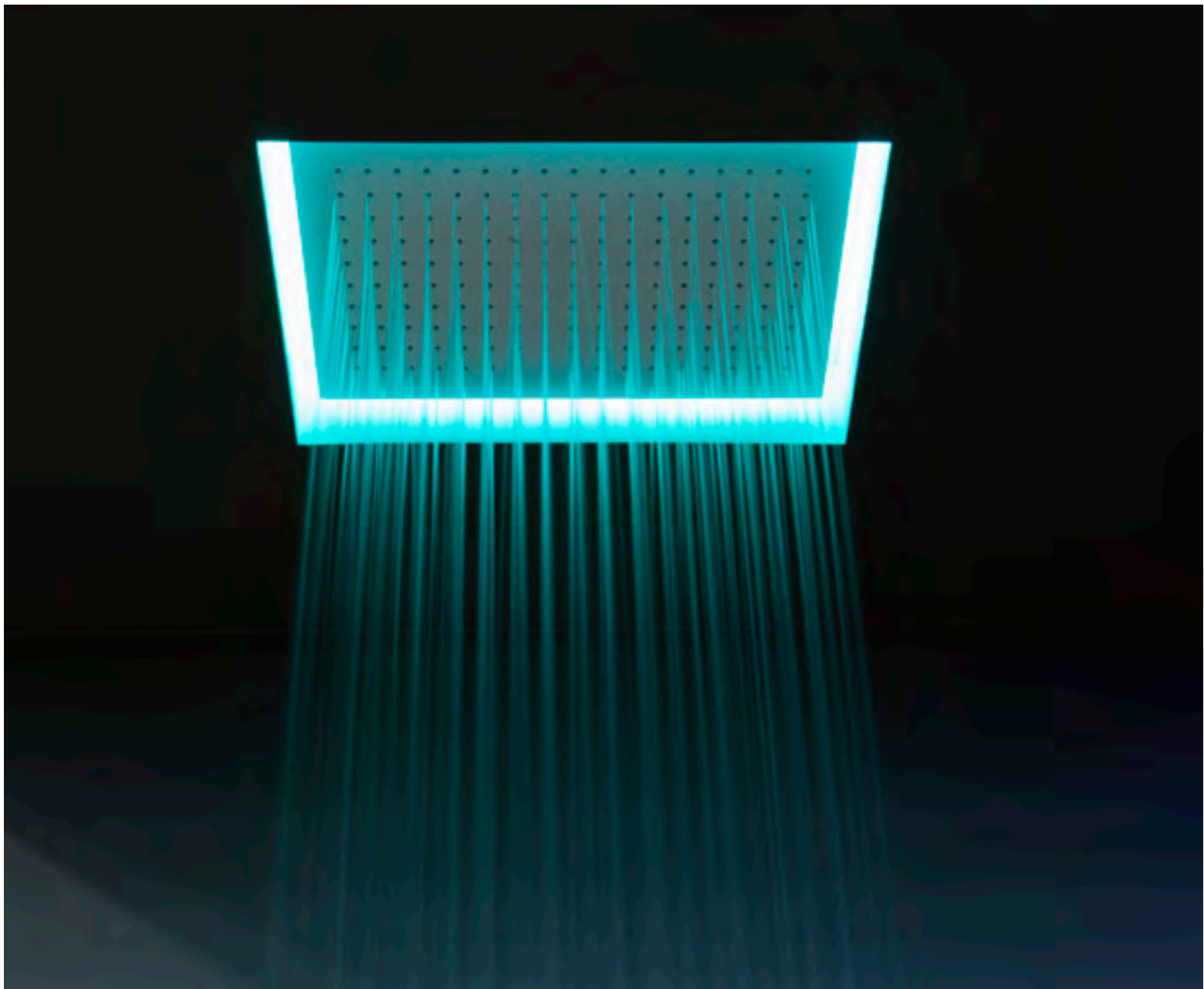

art. METEO1 L 35 P 35 H 11 cm

art. METEO2 L 52 P 35 H 11 cm

soffioni e rubinetteria  
overhead showers and taps

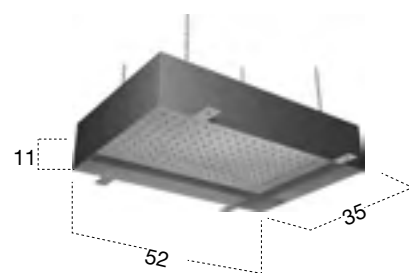
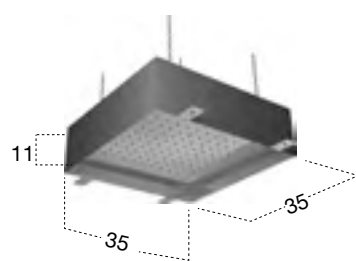

Soffione ad incasso in acciaio AISI 304 disponibile in diverse finiture con possibile illuminazione a led rgb comprensivo di telecomando.

*Encased showerhead in stainless steel AISI 304 available in various finishes, with possible rgb led lighting and remote.*

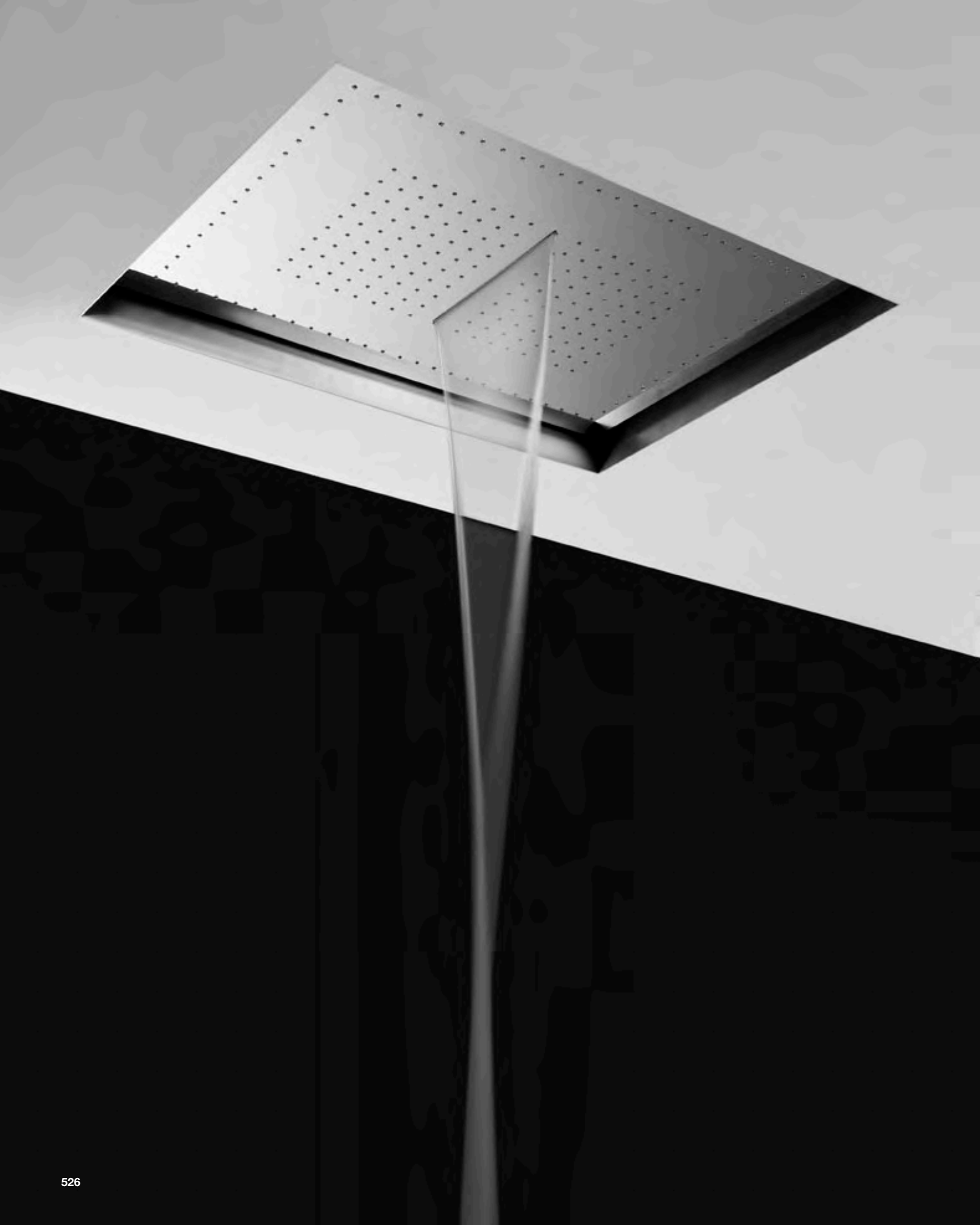

# METEO

L'Art. Meteo è composto da due elementi principali: telaio (E) e soffione (C). Una volta installato il soffione risulterà incassato a soffitto, questo è possibile grazie al telaio, realizzato appositamente per essere vincolato al soffitto in sospensione, è inoltre possibile inserire un corpo illuminante (D).

Art. Meteo consists of two main elements: frame (E) and showerhead (C). Once installed the showerhead will be embedded in the ceiling, thanks to the frame, designed specifically to be bound to a suspended ceiling, you can also place a light fixture (D).

- A - Soffitto**  
- Ceiling
- B - Fissaggio in sospensione**  
- Hanging supports
- C - Soffione**  
- Showerhead
- D - Vano per il posizionamento del corpo illuminante**  
- Space for light fixture
- E - Telaio**  
- Frame
- F - Il piano di erogazione dell' acqua (C) è incassato rispetto al controsoffitto**  
- Water outlet is recessed in the ceiling
- G - Controsoffitto**  
- Hanging ceiling

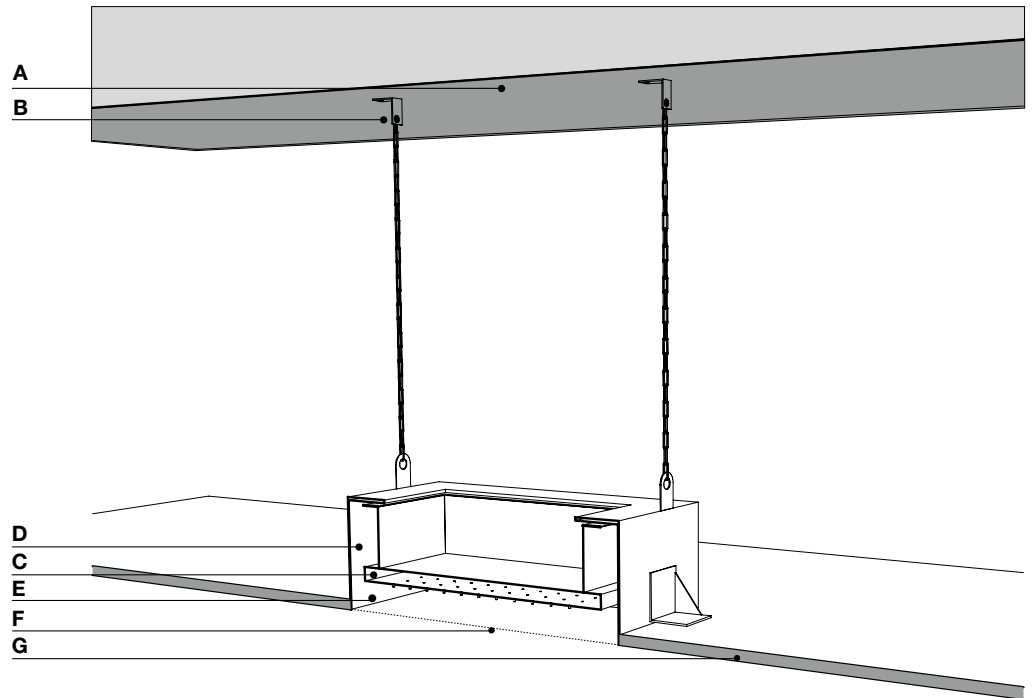

soffioni e rubinetteria  
overhead showers and taps

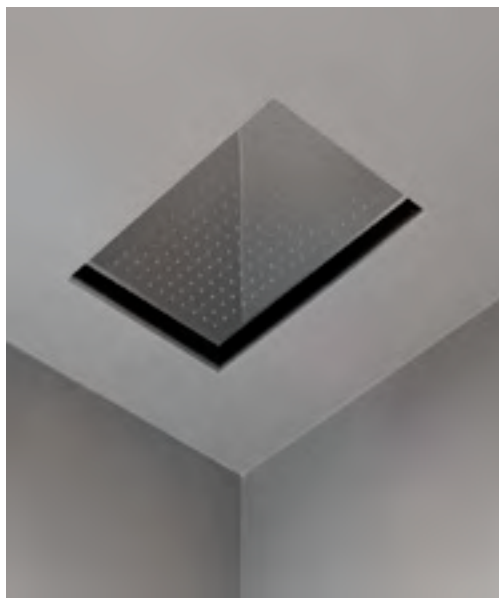

Telaio Acciaio Inox - Soffione Acciaio Mirror  
Frame Stainless Steel - Showerhead Mirrored Steel



Telaio Bianco - Soffione Acciaio Mirror  
Frame White - Showerhead Mirrored Steel



Telaio Bianco - Soffione Bianco  
Frame White - Showerhead White



# METEO





11



12



13



14



15



16



17



18



19



20

**FUORIMETEO** design Nevio Tellatin

Modello e design registrato  
*Registered model and design*

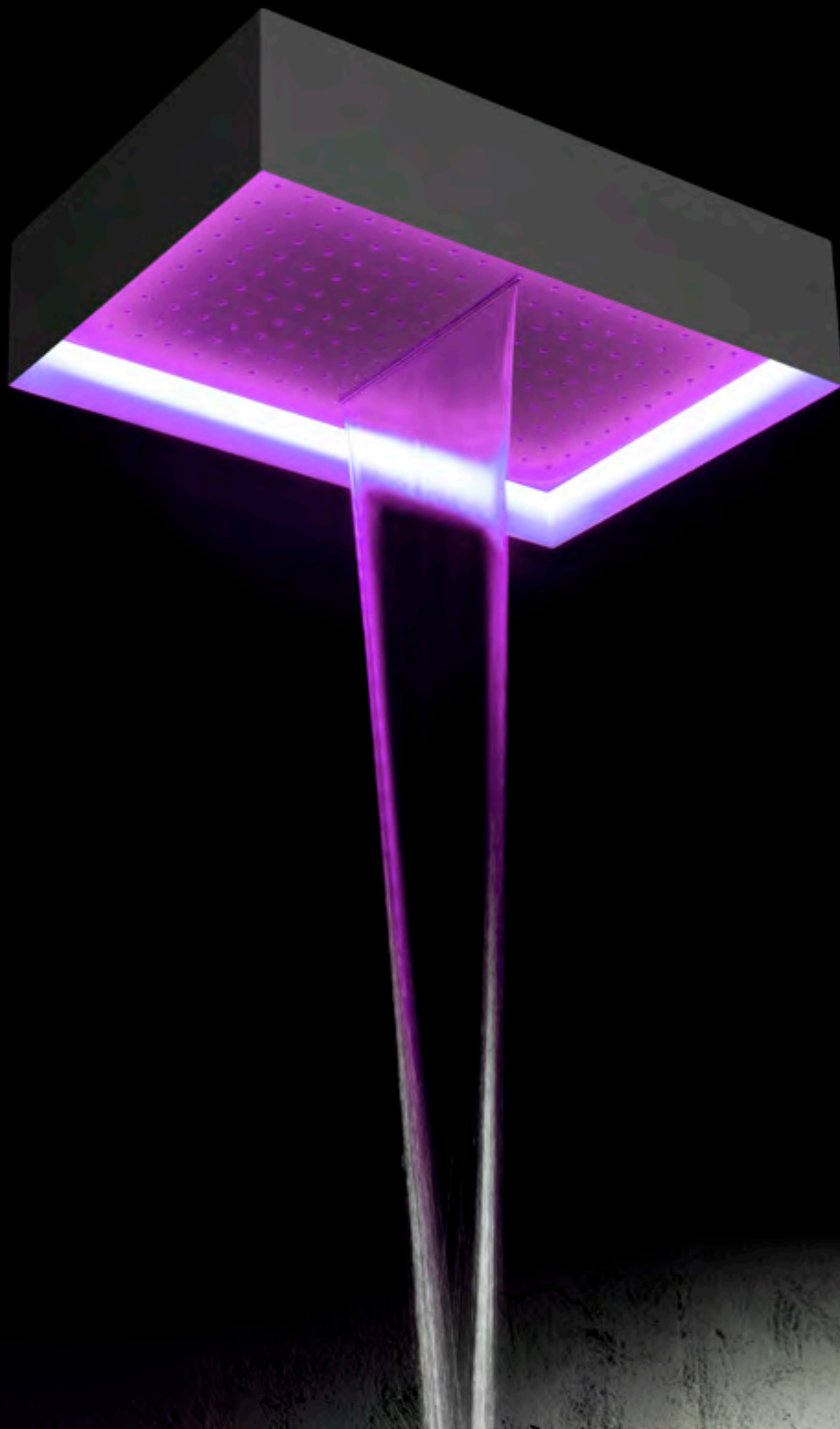



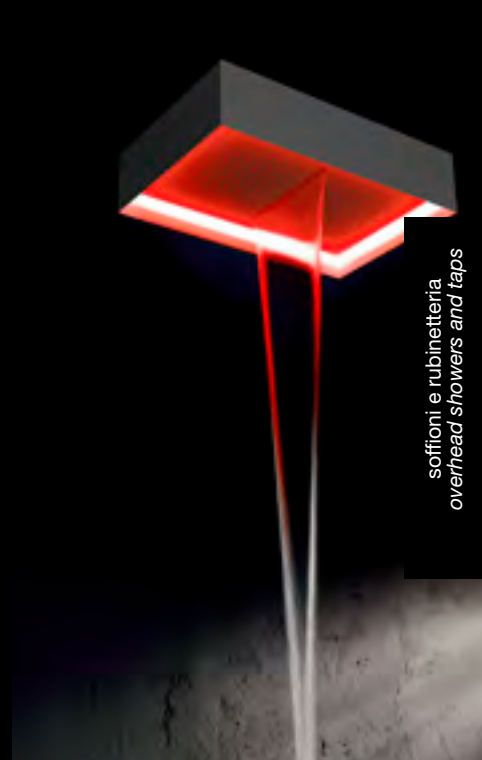
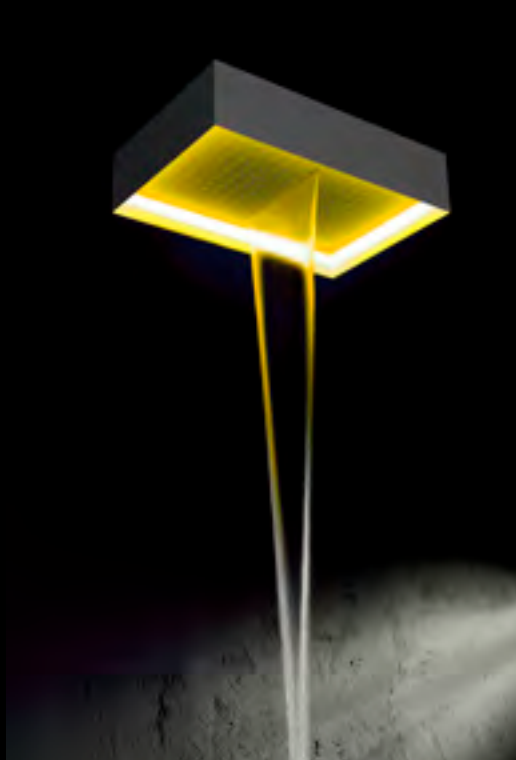
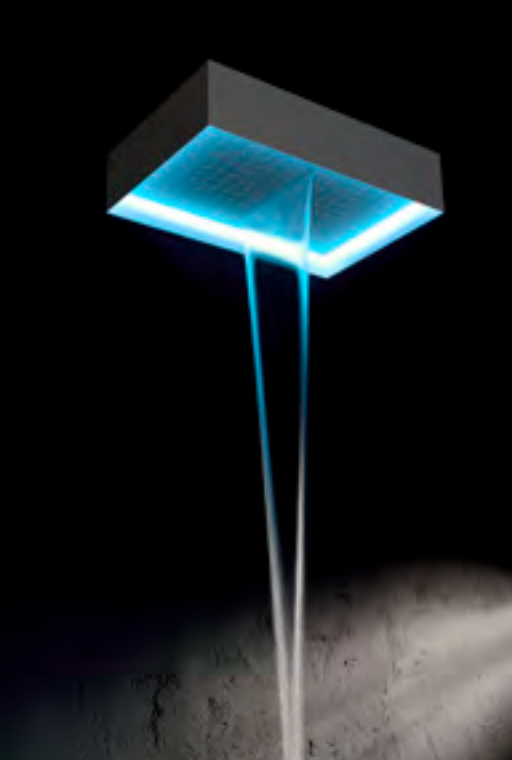

soffioni e rubinetteria  
overhead showers and taps

pioggia, cascata e arcobaleno / rain, waterfall and rainbow



# FUORIMETEO



soffioni e rubinetteria  
overhead showers and taps

art. FUORIMETEO10 L 35 P 35 H 13 cm

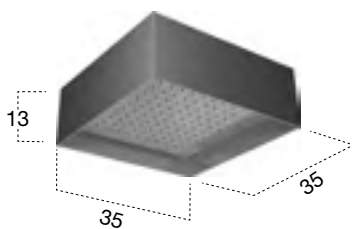

Soffione a soffitto con struttura esterna in acciaio AISI 304, disponibile in diverse finiture, con possibile illuminazione a led rgb comprensivo di telecomando.

*Ceiling mounted showerhead with steel AISI 304 outer frame available in various finishes, with possible rgb led lighting and remote.*



## FUORIMETEO

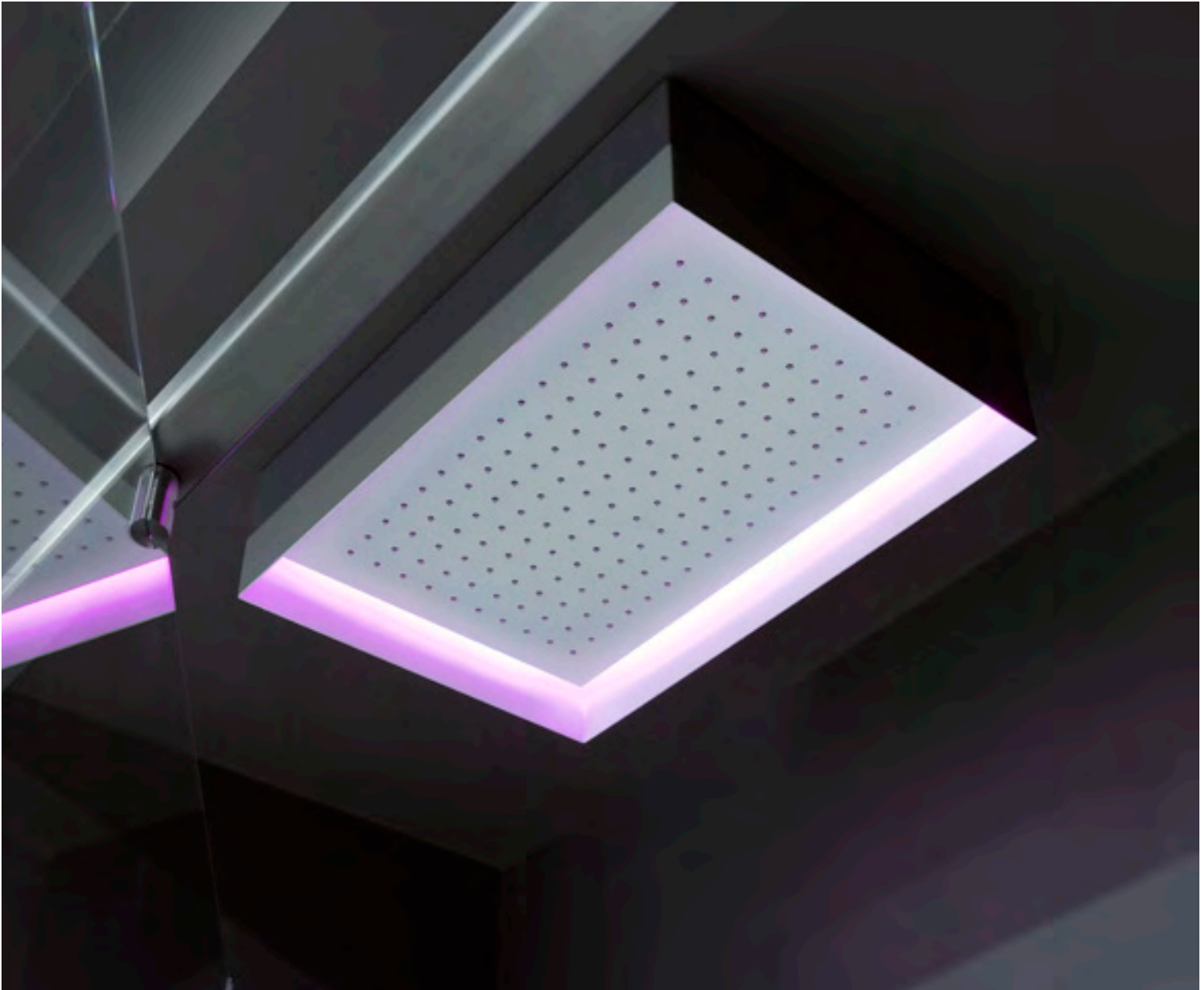

art. FUORIMETEO20 L 52 P 35 H 13 cm

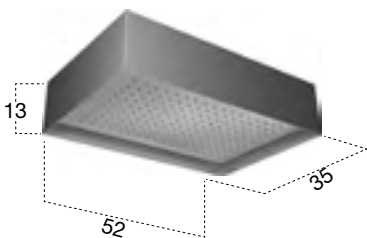

Soffione a soffitto con struttura esterna in acciaio AISI 304, disponibile in diverse finiture, con possibile illuminazione a led rgb comprensivo di telecomando.

*Ceiling mounted showerhead with steel AISI 304 outer frame available in various finishes, with possible rgb led lighting and remote.*

# FUORIMETEO



soffioni e rubinetteria  
overhead showers and taps

art. FUORIMETEO20C L 52 P 35 H 13 cm

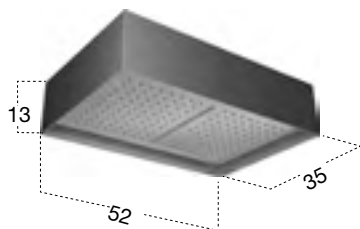

Soffione a soffitto con cascata e struttura esterna in acciaio AISI 304, disponibile in diverse finiture, con possibile illuminazione a led rgb comprensivo di telecomando.  
**N.B.** Necessita di deviatore a due vie.

*Celling mounted waterfall showerhead with steel AISI 304 outer frame available in various finishes, with possible rgb led lighting and remote.  
**P.S.** Requires two way diverter.*

## FUORIMETEO

Fuorimeteo viene fornito bianco, la struttura esterna può essere verniciata a piacimento, dello stesso colore della parete o in contrasto con essa.  
*Fuorimeteo is supplied white, the external structure can be lacquered as the client prefers, in the same color of the wall or using a different color.*







1



2



3



4



1



2



3

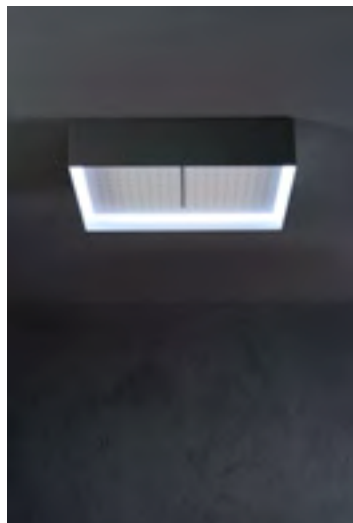

4

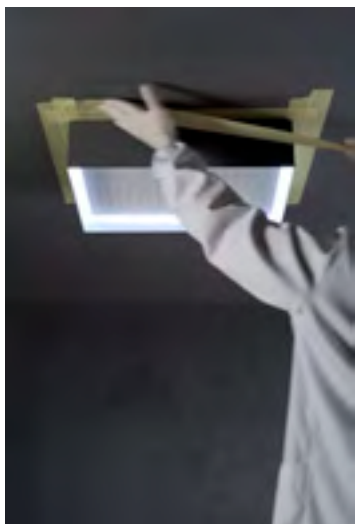

1



2



3

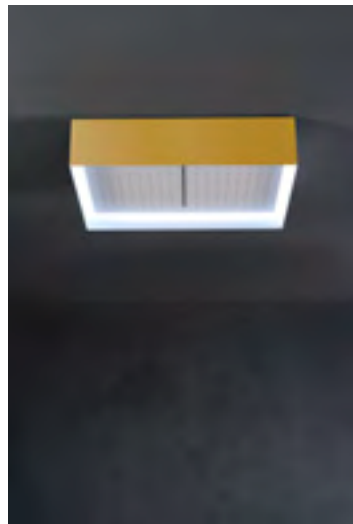

4

soffioni e rubinetteria  
overhead showers and taps

art. METEO1 / FUORIMETEO10

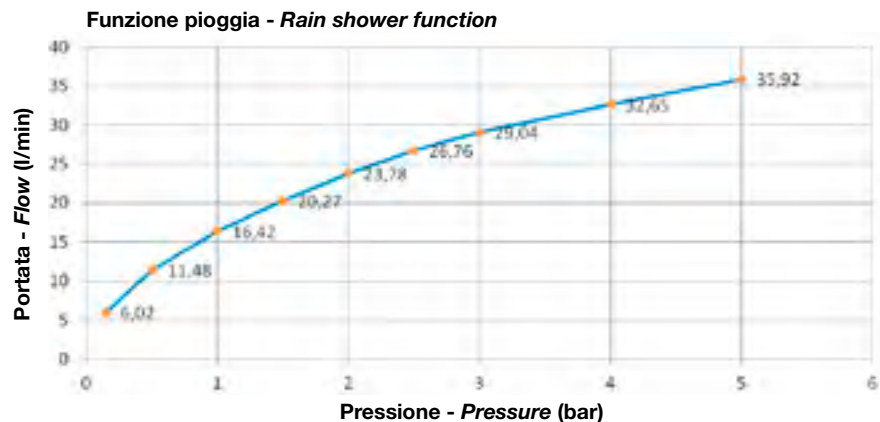

art. METEO2 / FUORIMETEO20

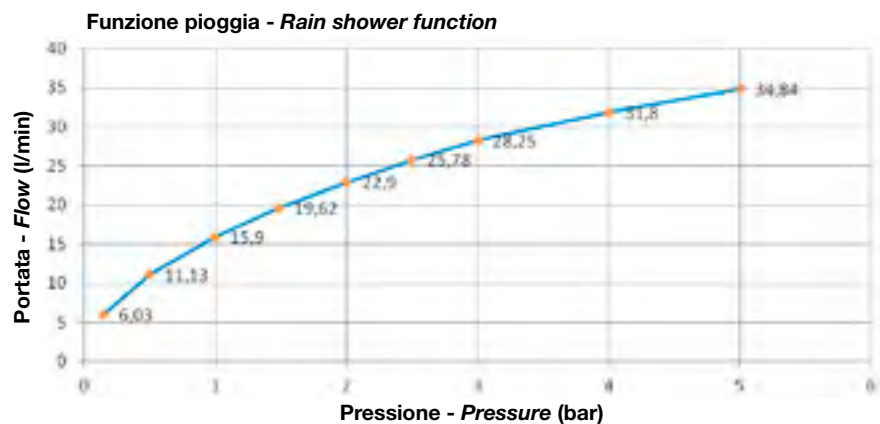

art. METEO2C / FUORIMETEO20C

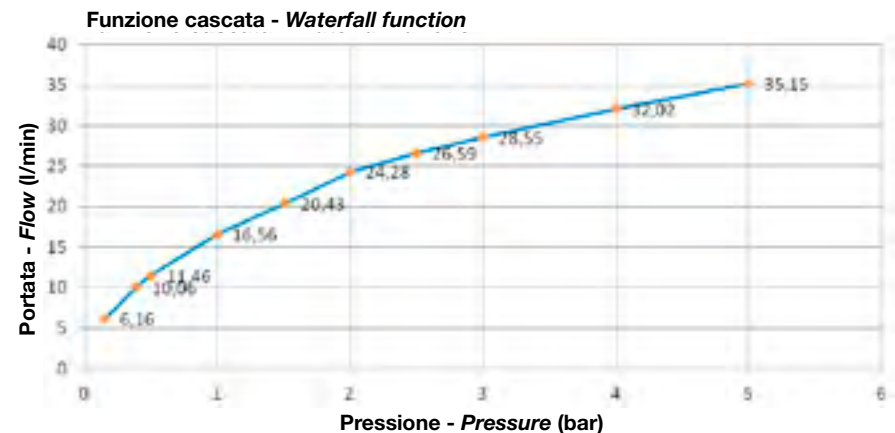
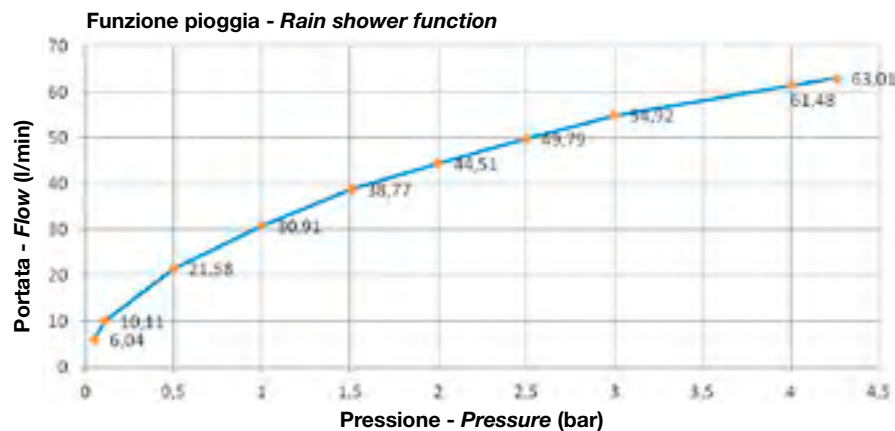

Funzione pioggia - *Rain shower function*

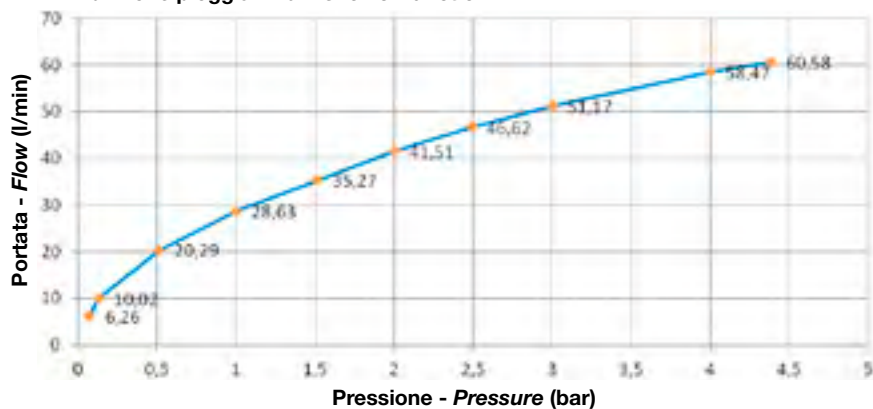

Funzione cascata - *Waterfall function*

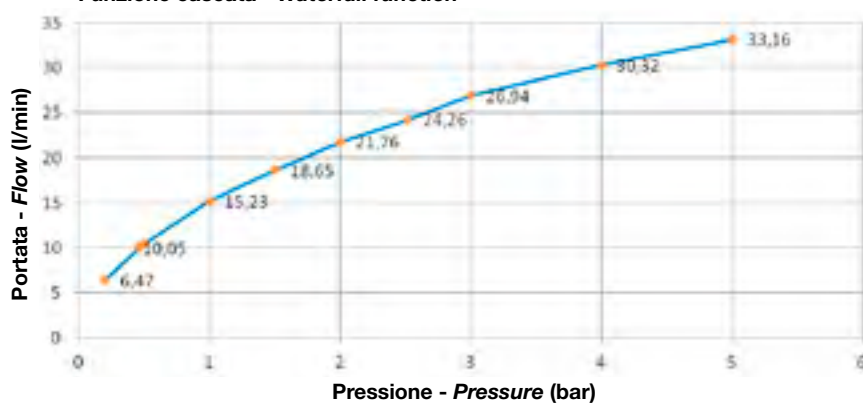

Funzione doccia perimetrale - *Peripheral rain shower function*

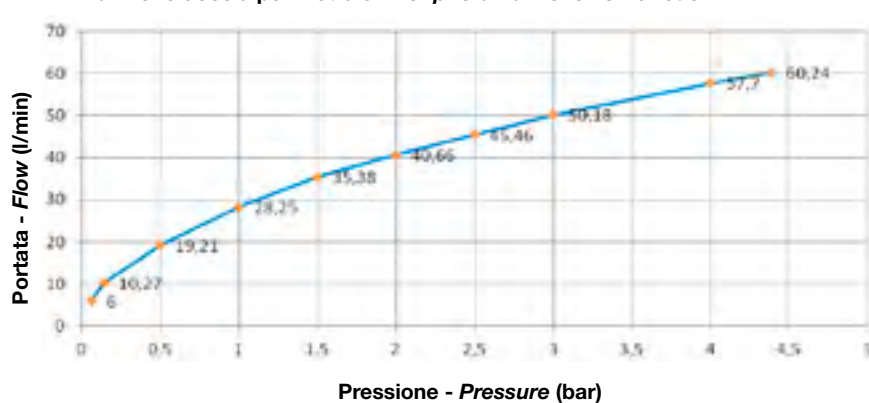

soffioni e rubinetteria  
overhead showers and taps







art. **METEO\_RA** L 40 P 40 H 10,5 cm  
art. **METEO\_RAL** L 40 P 40 H 10,5 cm con illuminazione a led / with led rgb

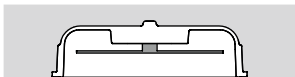

Struttura ad incasso in Cristalplant biobased con soffione in acciaio inox satinato AISI 304, con possibile illuminazione a led rgb comprensiva di telecomando.

*Encased biobased Cristalplant frame with stainless steel AISI 304 showerhead, with possible led rgb lighting complete with remote.*





# METEO\_RA



1



2



3



4



5



6



7



8



9



10

soffioni e rubinetteria  
overhead showers and taps

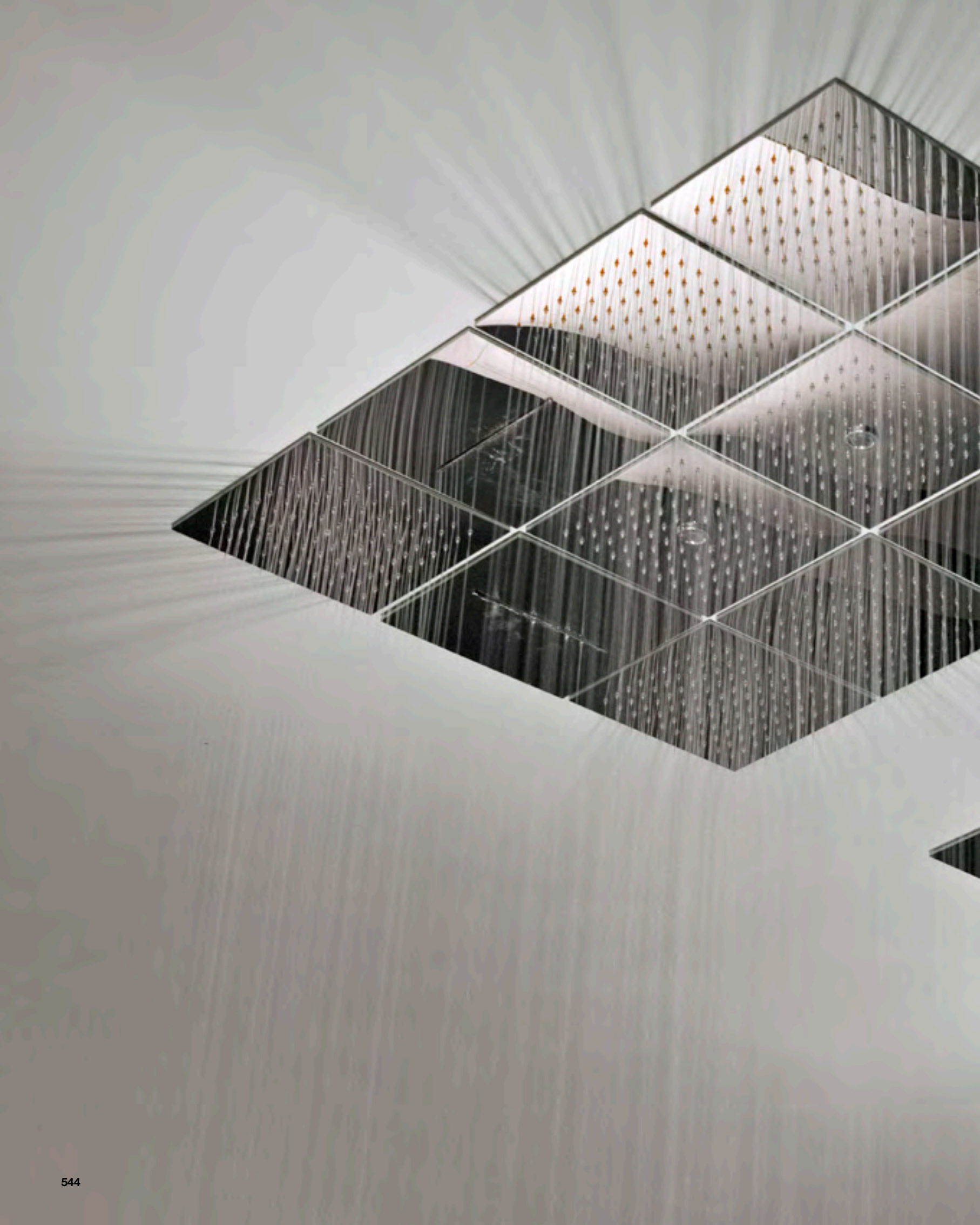





soffioni e rubinetteria  
overhead showers and taps





## LAMATTONELLA design Nevio Tellatin

E' l'inizio di un nuovo percorso progettuale parallelo a meteo, nel quale le funzioni del soffione vengono "scomposte". Gli elementi così ottenuti diventano modulari, accostabili tra loro o posizionabili liberamente nel soffitto. L'effetto che si ottiene è quello di una superficie piastrellata considerato lo spessore molto ridotto degli elementi che appaiono a filo soffitto.

Lo scopo è quello di rompere il tradizionale schema del soffione doccia singolo, non più un luogo definito dal quale l'acqua scende, ma la possibilità progettuale di creare percorsi. La progettazione dello spazio doccia diventa quindi meno rigida e la percezione dell'acqua che cade più naturale.

Il sistema di aggancio e installazione è rivoluzionario: ogni elemento è posizionato con un sistema ad incastro in un corpo in acciaio inox AISI 304 fissato al soffitto, risultano così molto semplici le operazioni di installazione ed eventuale rimozione.

*The beginning of a new project parallel to Meteo where the various functions of the showerhead are decomposed. The elements are modular and can be joined together or placed freely in the ceiling. The effect obtained is that of a tiled surface since the thickness of the elements is minimal appearing flush with the ceiling.*

*The purpose is to break-up the traditional usage of the single showerhead and give the possibility to create personal circuits. The design of the shower space becomes less rigid and perception of the water falling is more natural.*

*Its installation is revolutionary where each element is positioned with an interlocking system in a stainless steel AISI 304 body fixed to the ceiling and resulting in a very simple way of installing and or removing.*

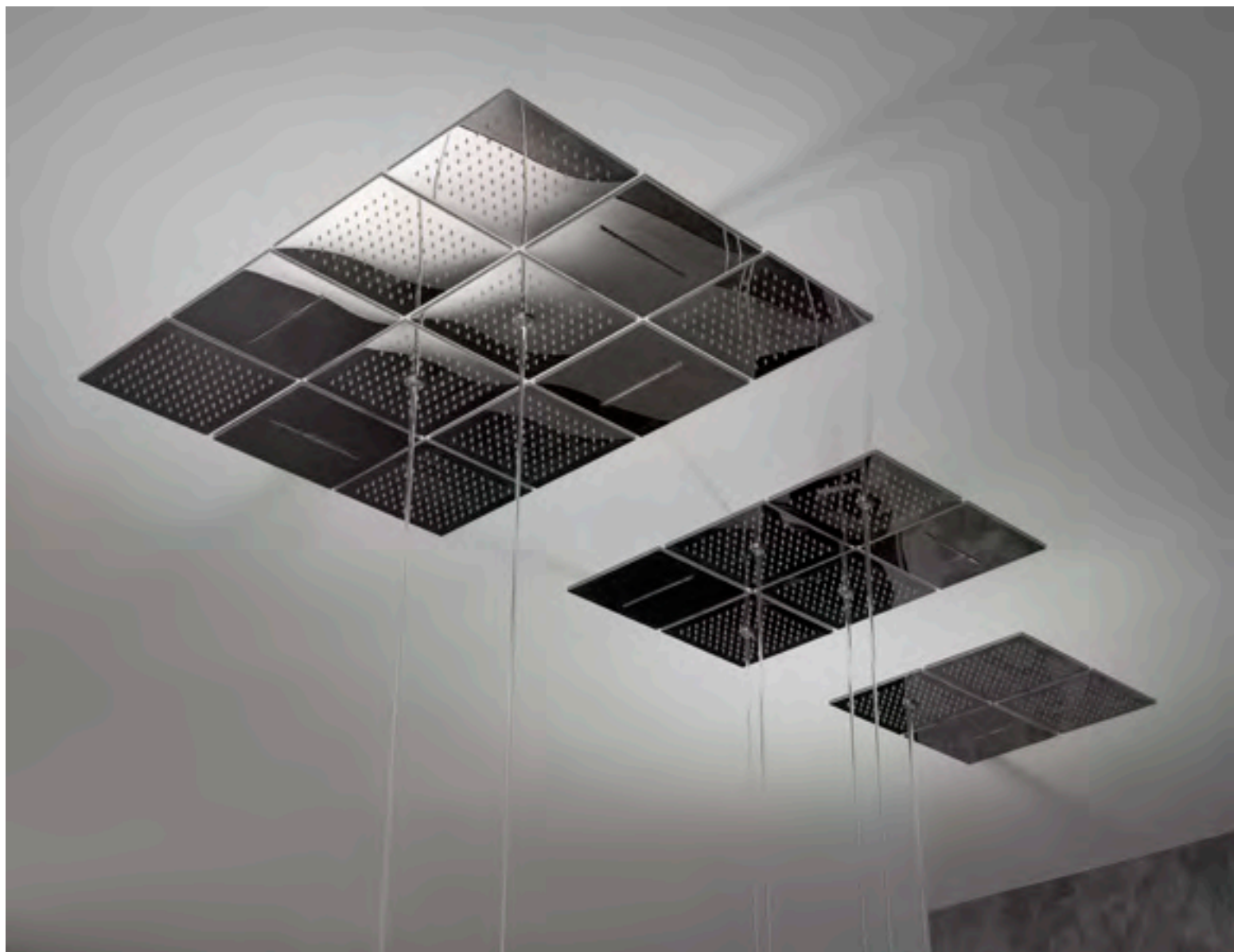

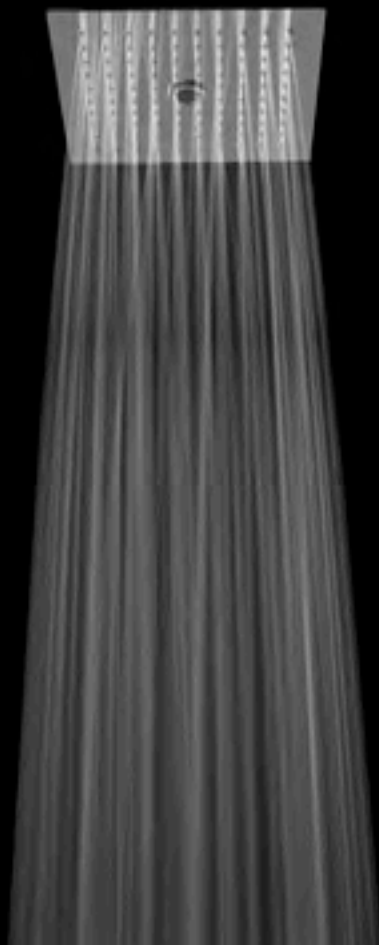

doccia + chiodo  
*shower + jet*

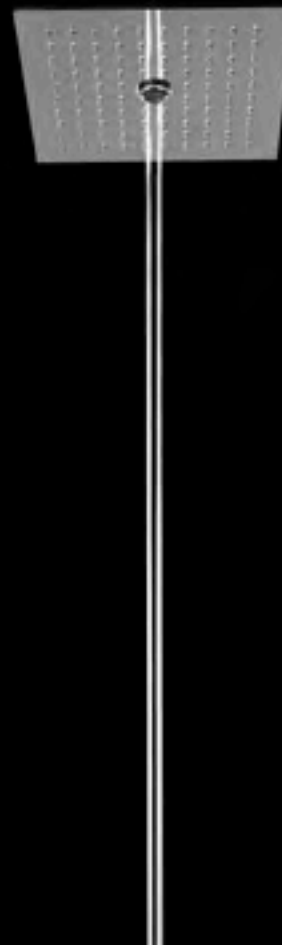

chiodo + doccia  
*jet + shower*



doccia  
*shower*



cascata  
*waterfall*



# LAMATTONELLA

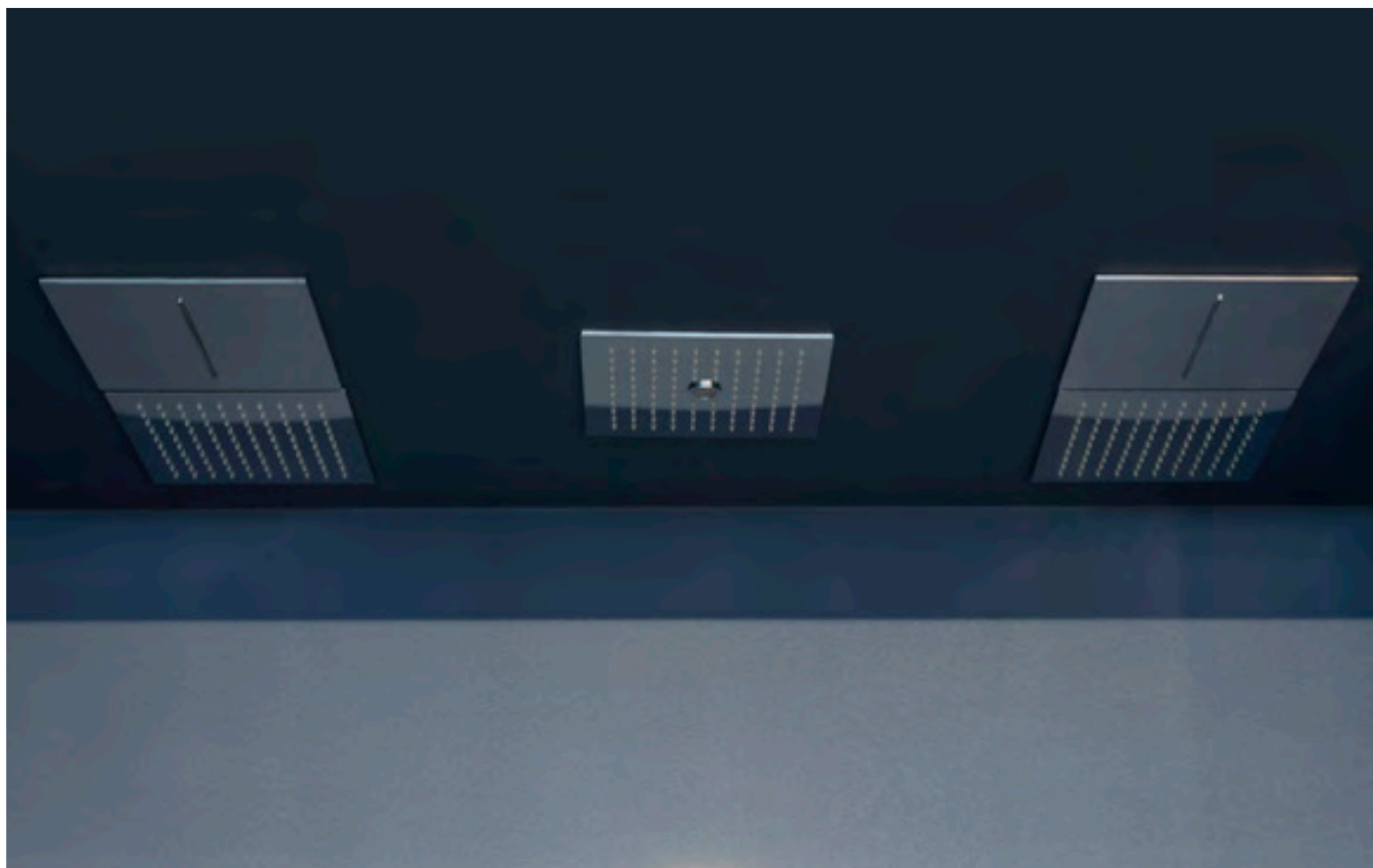

art. LMN1\_A

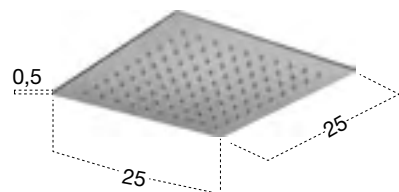

art. LMN2\_A

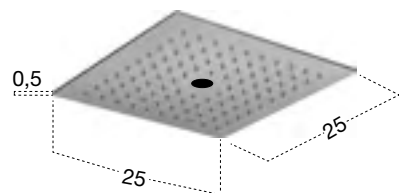

art. LMN3\_A

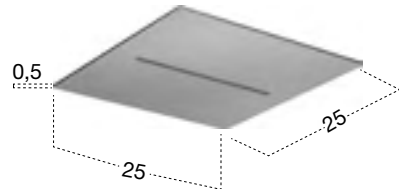

art. LMN1\_A

Soffione modulare ad incasso in acciaio inox lucido AISI 304.

*Encased modular showerhead in polished stainless steel AISI 304.*

art. LMN2\_A

Soffione modulare ad incasso con getto a chiodo in acciaio inox lucido AISI 304.

**N.B.** Necessita di deviatore a due vie.

*Encased modular showerhead with hard center jet in polished stainless steel AISI 304.*

**P.S.** Requires two way diverter.

art. LMN3\_A

Soffione modulare ad incasso a cascata in acciaio inox lucido AISI 304.

*Encased modular showerhead with waterfall in polished stainless steel AISI 304.*





soffioni e rubinetteria  
overhead showers and taps







soffioni e rubinetteria  
overhead showers and taps

art. VELA L 20,7 P 48,2 H 103 cm

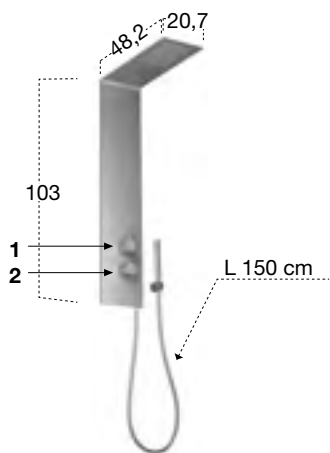

Colonna doccia a parete completa di soffione, miscelatore termostatico (2), rubinetto di comando con deviatore a due vie (1) e doccetta con flessibile 150 cm.

Showerhead column complete with thermostatic mixer (2), command handle with 2-way diverter (1) and hand shower with hose 150 cm.







art. **MEZZAVELA** L 50 P 27 H 12,3 cm

soffioni e rubinetteria  
overhead showers and taps

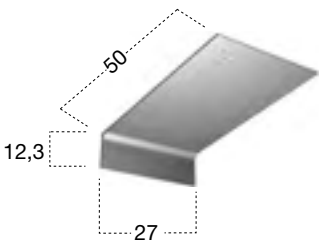

Soffione a parete in acciaio inox satinato AISI 304.  
*Satin stainless steel AISI 304 wall mounted showerhead.*



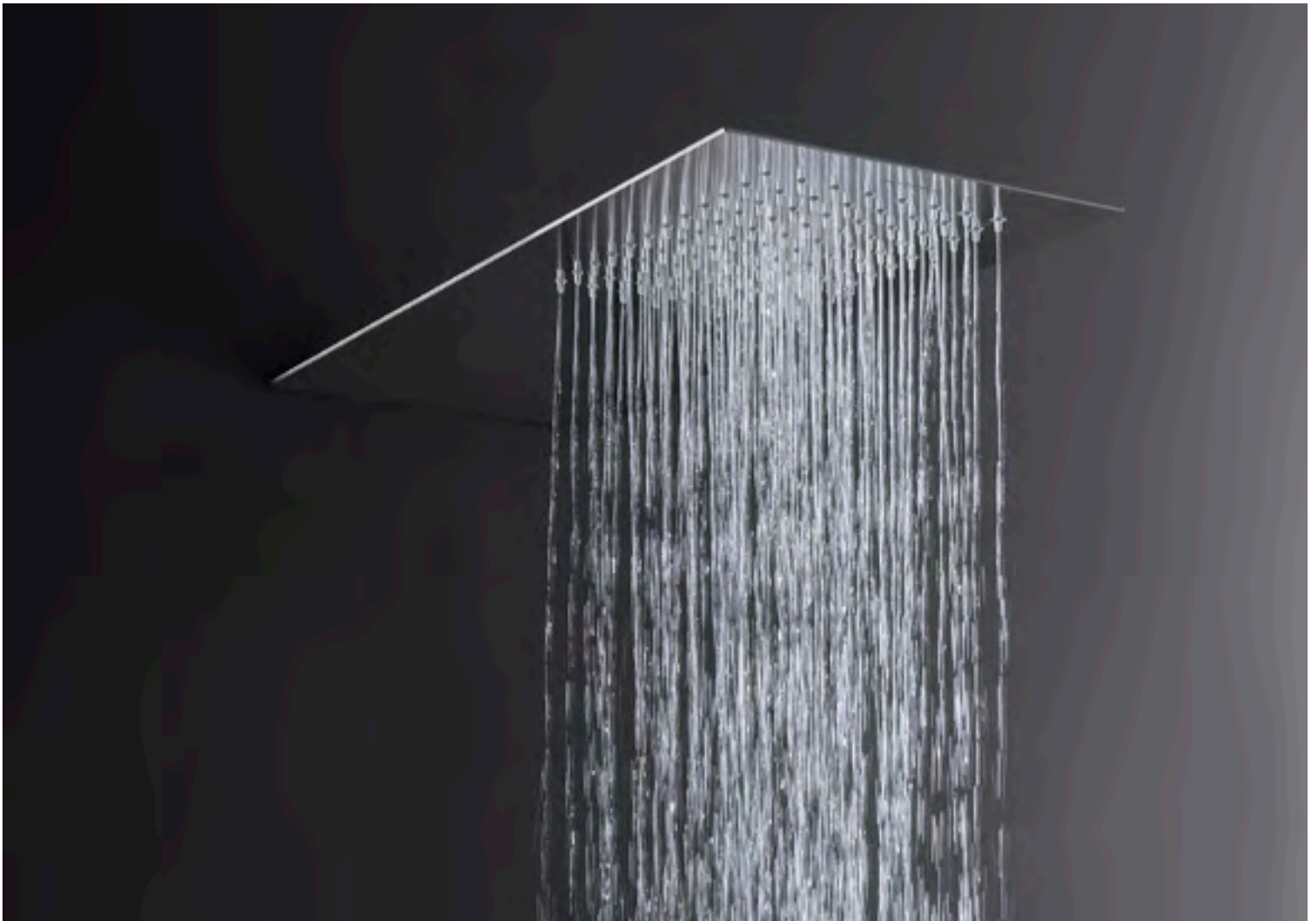

art. **LASTRA** L 20,7 P 50,3 H 2 cm

art. **BILASTRA** L 20,7 P 50,3 H 2 cm

soffioni e rubinetteria  
overhead showers and taps

art. **LASTRA**

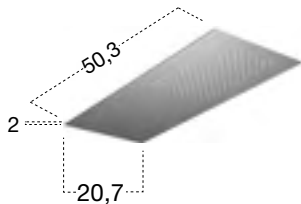

art. **BILASTRA**

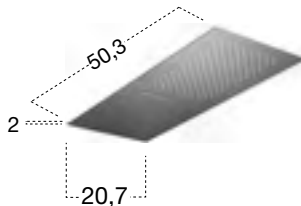

art. **LASTRA**

Soffione a parete in acciaio inox satinato AISI 304.

*Satin stainless steel AISI 304 wall mounted showerhead.*

art. **BILASTRA**

Soffione a parete con cascata in acciaio inox satinato AISI 304.  
**N.B.** Necessita di deviatore a due vie.

*Satin stainless steel AISI 304 wall mounted waterfall showerhead.*  
**P.S.** Requires two way diverter.





art. **PRISMA** L 27 P 16 H 4,5 cm

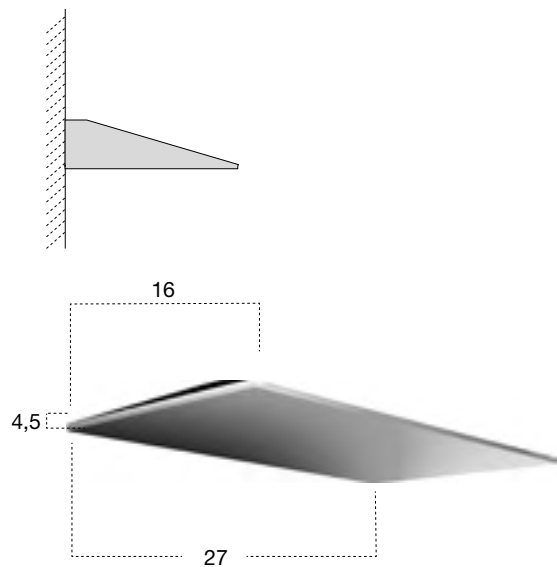

Erogatore a cascata per doccia con fissaggio a parete, in acciaio inox lucido AISI 304.

*Polished stainless steel AISI 304 wall mounted waterfall spout for shower .*



art. **SBALZO** L 15 P 15 H 6 cm

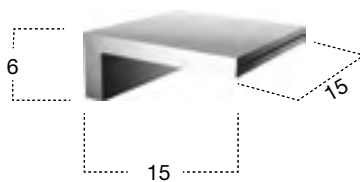
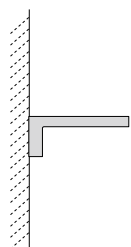

Erogatore a cascata per vasca con fissaggio a parete, in acciaio inox satinato AISI 304.

*Satin stainless steel AISI 304 wall mounted waterfall spout for bathtub.*

soffioni e rubinetteria  
overhead showers and taps



**AYATI** design Massimo Broglio

**Modello e design registrato**  
*Registered model and design*

Realizzato in acciaio inox AISI 304, finitura satinata o lucida.  
*Made of stainless steel AISI 304, satin or polished finish.*







soffioni e rubinetteria  
overhead showers and taps







soffioni e rubinetteria  
overhead showers and taps







soffioni e rubinetteria  
overhead showers and taps







soffioni e rubinetteria  
overhead showers and taps





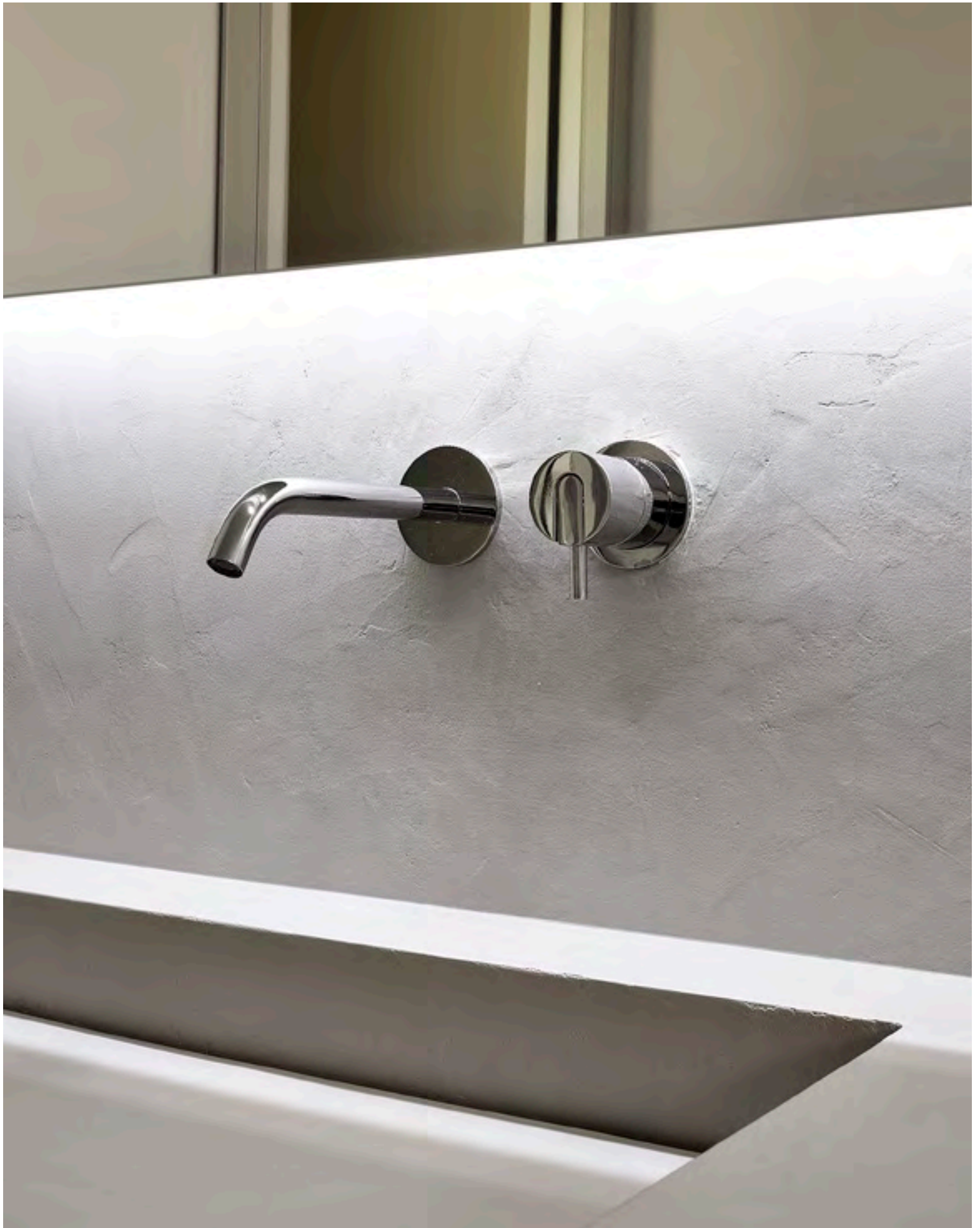

soffioni e rubinetteria  
overhead showers and taps





AYATI



soffioni e rubinetteria  
overhead showers and taps







AYATI



soffioni e rubinetteria  
overhead showers and taps







soffioni e rubinetteria  
overhead showers and taps







soffioni e rubinetteria  
overhead showers and taps













# AYATI

Programma rubinetteria di estrema versatilità, con possibilità di realizzare canne su misura, interamente realizzato in acciaio inox AISI 304, finitura satinata o lucida.

*Highly versatile taps series, with the ability to create custom spouts, made entirely of stainless steel AISI 304, satin or polished finish.*

**Acciaio Satinato / Satin Stainless Steel "SA"**

**Acciaio Lucido / Polished Stainless Steel "LU"**

Miscelatore monocomando per bidet.

*Single lever mixer for bidet.*

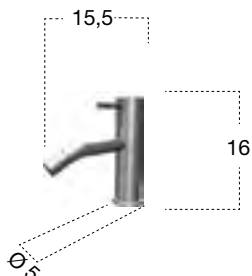

H	P	Ø	art.
16	15,5	5	<b>AY400SA</b>
16	15,5	5	<b>AY400LU</b>

Miscelatore monocomando da piano per lavabo.

*Single lever basin mixer for top mounting.*

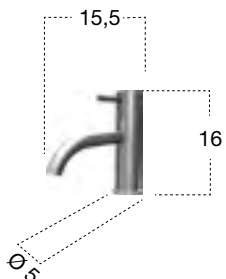

H	P	Ø	art.
16	15,5	5	<b>AY301SA</b>
16	15,5	5	<b>AY301LU</b>

Miscelatore monocomando da piano per lavabo.

*Single lever basin mixer for top mounting.*

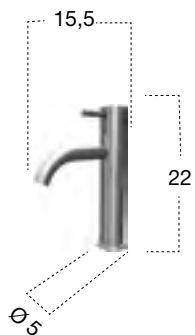

H	P	Ø	art.
22	15,5	5	<b>AY302SA</b>
22	15,5	5	<b>AY302LU</b>

Miscelatore monocomando da piano per lavabo.

*Single lever basin mixer for top mounting.*



H	P	Ø	art.
35	27,3	5	<b>AY303SA</b>
35	27,3	5	<b>AY303LU</b>

soffioni e rubinetteria  
overhead showers and taps



Miscelatore monocomando da piano per lavabo.

*Single lever basin mixer for top mounting.*



H	P	Ø	art.
45	27,3	5	<b>AY304SA</b>
45	27,3	5	<b>AY304LU</b>

Prolunga per Art. AY304SA e Art. AY304LU.

*Extension for Art. AY304SA and Art. AY304LU.*

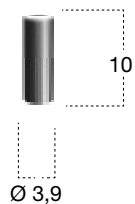

H	Ø	art.
10	3,9	<b>AY304PRSA</b>
10	3,9	<b>AY304PRLU</b>

Corpo ad incasso per art. **AY902SA**, art. **AY902LU**, art. **AY903SA** e art. **AY903LU**.

*Concealed valve for art. **AY902SA**, art. **AY902LU**, art. **AY903SA** and art. **AY903LU**.*

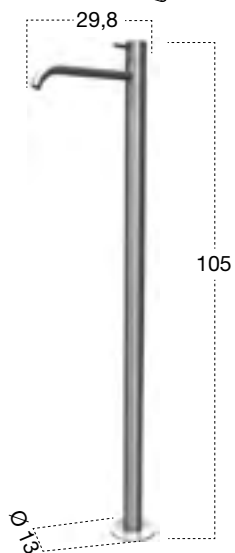

art.  
**AY902IN**

Miscelatore monocomando da terra per lavabo, escluso di corpo ad incasso.

*Free standing single lever sink mixer, concealed valve not included.*

H	P	Ø	art.
105	29,8	13	<b>AY902SA</b>
105	29,8	13	<b>AY902LU</b>

Corpo ad incasso per art. **AY202SA**, art. **AY202LU** art. **AY200SA**, art. **AY200LU**, art. **AY201SA** e art. **AY201LU**.

*Concealed valve for art. **AY202SA**, art. **AY202LU** art. **AY200SA**, art. **AY200LU**, art. **AY201SA** and art. **AY201LU**.*

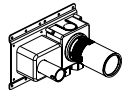

art.

**AY201NSA**

**AY201INLU**

Miscelatore monocomando a parete per lavabo, escluso di corpo ad incasso.

*Single lever wall mount sink mixer, concealed valve not included.*

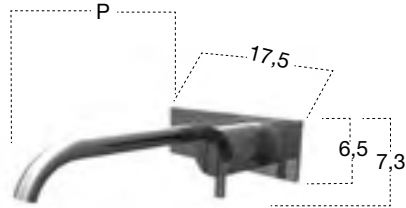

H	P	L	art.
7,3	10	17,5	<b>AY202SA</b>
7,3	10	17,5	<b>AY202LU</b>
7,3	19,8	17,5	<b>AY200SA</b>
7,3	19,8	17,5	<b>AY200LU</b>
7,3	25,8	17,5	<b>AY201SA</b>
7,3	25,8	17,5	<b>AY201LU</b>

Corpo ad incasso per art. **AY920SA**, art. **AY920LU**, art. **AY921SA**, art. **AY921LU**, art. **AY922SA**, art. **AY922LU**.

*Concealed valve for art. **AY920SA**, art. **AY920LU**, art. **AY921SA**, art. **AY921LU** art. **AY922SA**, art. **AY922LU**.*

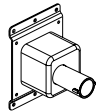

art.

**AY921IN**

Erogatore a parete per lavabo, escluso di corpo a incasso.

*Wall mount sink spout, concealed valve not included.*

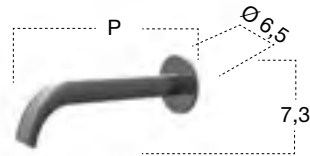

H	P	Ø	art.
7,3	10	6,5	<b>AY920SA</b>
7,3	10	6,5	<b>AY920LU</b>
7,3	19,8	6,5	<b>AY921SA</b>
7,3	19,8	6,5	<b>AY921LU</b>
7,3	25,8	6,5	<b>AY922SA</b>
7,3	25,8	6,5	<b>AY922LU</b>

Corpo ad incasso per art. **AY600SA** e art. **AY600LU**.

*Concealed valve for art. **AY600SA** and art. **AY600LU**.*

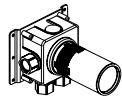

art.

**AY600NSA**

**AY600INLU**

Miscelatore monocomando per lavabo da incasso a parete, escluso di corpo a incasso.

*Single lever sink mixer part only for wall encasing, concealed valve not included.*



H	P	Ø	art.
6,8	4,5/7	6,5	<b>AY600SA</b>
6,8	4,5/7	6,5	<b>AY600LU</b>

Corpo ad incasso per art. **AY902SA**, art. **AY902LU**, art. **AY903SA** e art. **AY903LU**.

Concealed valve for art. **AY902SA**, art. **AY902LU**, art. **AY903SA** and art. **AY903LU**.

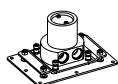

art.

**AY902IN**

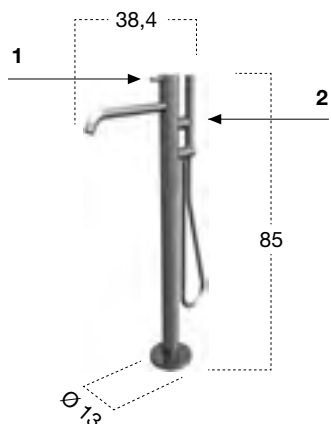

Colonna da terra per vasca, completa di miscelatore per erogazione (1), miscelatore per doccia (2) e doccia con flessibile 150 cm, escluso di corpo ad incasso.

Freestanding bath mixer, complete with mixer for spout (1), hand shower mixer (2) and hand shower with flexible hose 150 cm, concealed valve not included.

H	P	Ø	art.
85	38,4	13	<b>AY903SA</b>
85	38,4	13	<b>AY903LU</b>

Gruppo bordo vasca completo di rubinetti di comando acqua calda e fredda (1), miscelatore per doccia (2) e doccia con flessibile 150 cm a scomparsa.

Bath rim set complete with hot and cold water handles (1), shower mixer (2) and hand shower with hidden hose 150 cm.

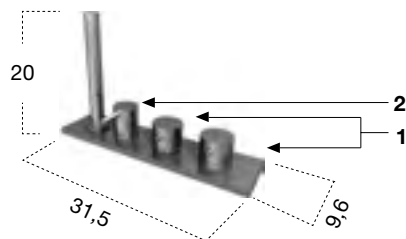

H	P	L	art.
20	9,6	31,5	<b>AY702SA</b>
20	9,6	31,5	<b>AY702LU</b>

Gruppo bordo vasca completo di erogatore, rubinetti di comando acqua calda e fredda (1), miscelatore per doccia (2) e doccia con flessibile 150 cm a scomparsa.

Bath rim set complete with spout, hot and cold water handles (1), shower mixer (2) and hand shower with hidden hose 150 cm.

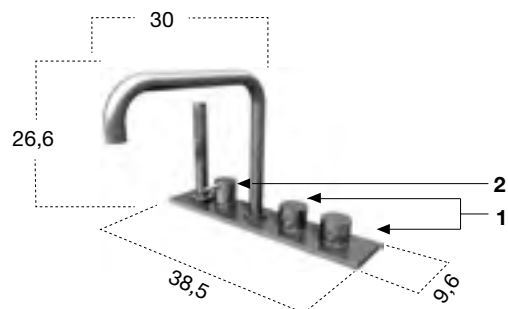

H	P	L	art.
26,6	30	38,5	<b>AY701SA</b>
26,6	30	38,5	<b>AY701LU</b>



Doccetta completa di supporto e presa d'acqua a parete con flessibile 150 cm.

Hand shower with hose cm 150, wall outlet and holder.

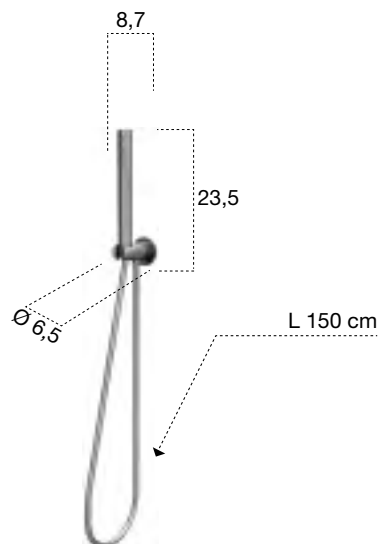

H	P	L	art.
23,5	8,7	6,5	<b>AY150SA</b>
23,5	8,7	6,5	<b>AY150LU</b>

Corpo ad incasso per art. **AY601SA** e art. **AY601LU**.

Concealed valve for art. **AY601SA** and art. **AY601LU**.

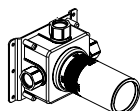

art.

**AY601INSA**

**AY601INLU**

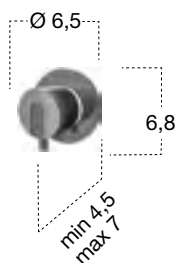

Miscelatore monocomando per doccia da incasso a parete, escluso di corpo a incasso.

Single lever shower mixer part only for wall encasing, concealed valve not included.

H	P	Ø	art.
6,8	4,5/7	6,5	<b>AY601SA</b>
6,8	4,5/7	6,5	<b>AY601LU</b>

Corpo ad incasso per art. **AY604SA** e art. **AY604LU**.

Concealed valve for art. **AY604SA** and art. **AY604LU**.

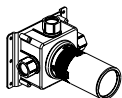

art.

**AY604INSA**

**AY604INLU**



Miscelatore termostatico coassiale con apertura e chiusura acqua, escluso di corpo a incasso.

Coaxial thermostatic mixer with command handle, concealed valve not included.

H	P	Ø	art.
8	6,1/8,6	6,5	<b>AY604SA</b>
8	6,1/8,6	6,5	<b>AY604LU</b>

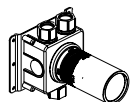

Corpo ad incasso per art. **AY602SA** e art. **AY602LU**.

*Concealed valve for art. **AY602SA** and art. **AY602LU**.*

art.

**AY602INSA**

**AY602INLU**



Deviatore incasso a due vie, escluso di corpo ad incasso.

*Encased two way diverter, concealed valve not included.*

P	Ø	art.
4,5/7	6,5	<b>AY602SA</b>
4,5/7	6,5	<b>AY602LU</b>

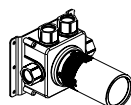

Corpo ad incasso per art. **AY603SA** e art. **AY603LU**.

*Concealed valve for art. **AY603SA** and art. **AY603LU**.*

art.

**AY603INSA**

**AY603INLU**



Deviatore incasso a tre vie, escluso di corpo a incasso.

*Encased three way diverter, concealed valve not included.*

P	Ø	art.
4,5/7	6,5	<b>AY603SA</b>
4,5/7	6,5	<b>AY603LU</b>

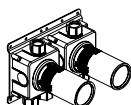

Corpo ad incasso per art. **AY650PSA**, art. **AY650PLU**, art. **AY650RSA** e art. **AY650RLU**.

*Concealed valve for art. **AY650PSA**, art. **AY650PLU**, art. **AY650RSA** and art. **AY650RLU**.*

art.

**AY650INSA**

**AY650INLU**

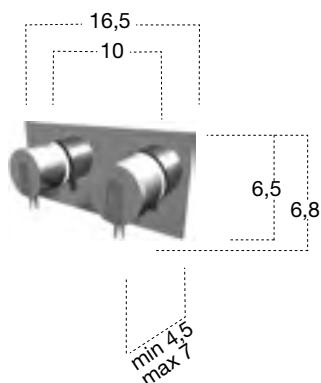

Composizione doccia (2 miscelatori), escluso di corpo a incasso.

*Shower set (2 mixers), concealed valve not included.*

H	P	L	art.
6,8	4,5/7	16,5	<b>AY650PSA</b>
6,8	4,5/7	16,5	<b>AY650PLU</b>

Corpo ad incasso per art. **AY650PSA**, art. **AY650PLU**, art. **AY650RSA** e art. **AY650RLU**.  
*Concealed valve for art. **AY650PSA**, art. **AY650PLU**, art. **AY650RSA** and art. **AY650RLU**.*

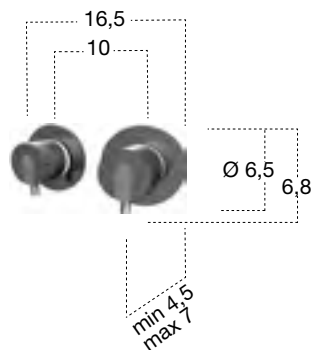
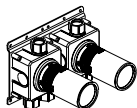

Composizione doccia (2 miscelatori), escluso di corpo a incasso.  
*Shower set (2 mixers), concealed valve not included.*

H	P	L	art.
6,8	4,5/7	16,5	<b>AY650RSA</b>
6,8	4,5/7	16,5	<b>AY650RLU</b>

art.  
**AY650INSA**  
**AY650INLU**

Corpo ad incasso per art. **AY651PSA**, art. **AY651PLU**, art. **AY651RSA** e art. **AY651RLU**.  
*Concealed valve for art. **AY651PSA**, art. **AY651PLU**, art. **AY651RSA** and art. **AY651RLU**.*

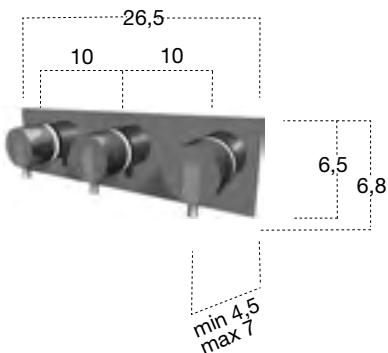
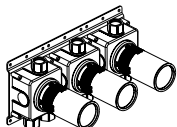

Composizione doccia (3 miscelatori), escluso di corpo a incasso.  
*Shower set (3 mixers), concealed valve not included.*

H	P	L	art.
6,8	4,5/7	26,5	<b>AY651PSA</b>
6,8	4,5/7	26,5	<b>AY651PLU</b>

art.  
**AY651INSA**  
**AY651INLU**

Corpo ad incasso per art. **AY651PSA**, art. **AY651PLU**, art. **AY651RSA** e art. **AY651RLU**.  
*Concealed valve for art. **AY651PSA**, art. **AY651PLU**, art. **AY651RSA** and art. **AY651RLU**.*

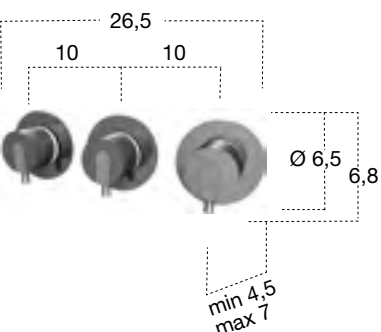
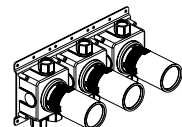

Composizione doccia (3 miscelatori), escluso di corpo ad incasso.  
*Shower set (3 mixers), concealed valve not included.*

H	P	L	art.
6,8	4,5/7	26,5	<b>AY651RSA</b>
6,8	4,5/7	26,5	<b>AY651RLU</b>

art.  
**AY651INSA**  
**AY651INLU**

soffioni e rubinetteria  
overhead showers and taps



Corpo ad incasso per art. **AY652PSA**, art. **AY652PLU**, art. **AY652RSA** e art. **AY652RLU**.

*Concealed valve for art. **AY652PSA**, art. **AY652PLU**, art. **AY652RSA** and art. **AY652RLU**.*

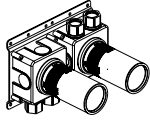

art.

**AY652INSA**

**AY652INLU**

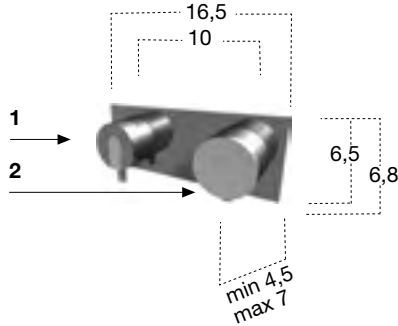

Composizione doccia 1 miscelatore (1) e 1 deviatore 2 vie (2), escluso di corpo a incasso.

*Shower set 1 mixer (1), 1 two way diverter (2), concealed valve not included.*

H	P	L	art.
6,8	4,5/7	16,5	<b>AY652PSA</b>
6,8	4,5/7	16,5	<b>AY652PLU</b>

Corpo ad incasso per art. **AY652PSA**, art. **AY652PLU**, art. **AY652RSA** e art. **AY652RLU**.

*Concealed valve for art. **AY652PSA**, art. **AY652PLU**, art. **AY652RSA** and art. **AY652RLU**.*

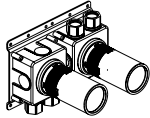

art.

**AY652INSA**

**AY652INLU**

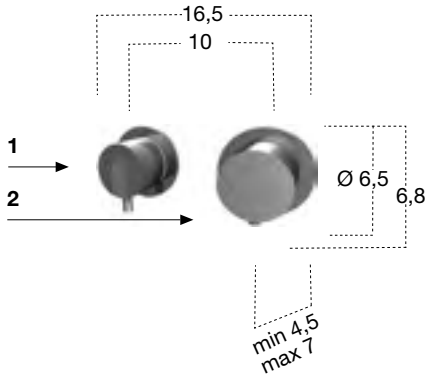

Composizione doccia 1 miscelatore (1) e 1 deviatore 2 vie (2), escluso di corpo a incasso.

*Shower set 1 mixer (1), 1 two way diverter (2), concealed valve not included.*

H	P	L	art.
6,8	4,5/7	16,5	<b>AY652RSA</b>
6,8	4,5/7	16,5	<b>AY652RLU</b>

Corpo ad incasso per art. **AY653PSA**, art. **AY653PLU**, art. **AY653RSA** e art. **AY653RLU**.

*Concealed valve for art. **AY653PSA**, art. **AY653PLU**, art. **AY653RSA** and art. **AY653RLU**.*

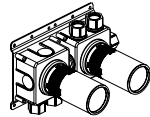

art.

**AY653INSA**

**AY653INLU**

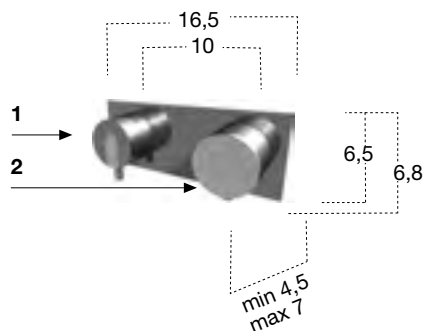

Composizione doccia 1 miscelatore (1) e 1 deviatore 3 vie (2), escluso di corpo a incasso.

*Shower set 1 mixer (1), 1 three way diverter (2), concealed valve not included.*

H	P	L	art.
6,8	4,5/7	16,5	<b>AY653PSA</b>
6,8	4,5/7	16,5	<b>AY653PLU</b>

Corpo ad incasso per art. **AY653PSA**, art. **AY653PLU**, art. **AY653RSA** e art. **AY653RLU**.

*Concealed valve for art. **AY653PSA**, art. **AY653PLU**, art. **AY653RSA** and art. **AY653RLU**.*

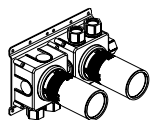

art.

**AY653INSA**

**AY653INLU**

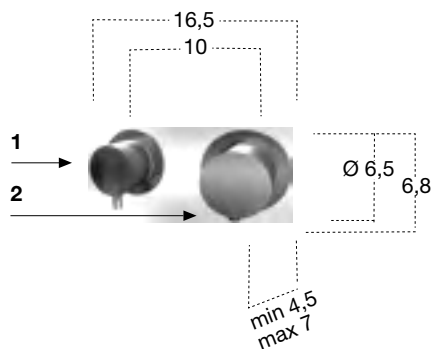

Composizione doccia 1 miscelatore (1) e 1 deviatore 3 vie (2), escluso di corpo a incasso.

*Shower set 1 mixer (1), 1 three way diverter (2), concealed valve not included.*

H	P	L	art.
6,8	4,5/7	16,5	<b>AY653RSA</b>
6,8	4,5/7	16,5	<b>AY653RLU</b>

Corpo ad incasso per art. **AY654PSA**, art. **AY654PLU**, art. **AY654RSA** e art. **AY654RLU**.

*Concealed valve for art. **AY654PSA**, art. **AY654PLU**, art. **AY654RSA** and art. **AY654RLU**.*

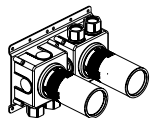

art.

**AY654INSA**

**AY654INLU**

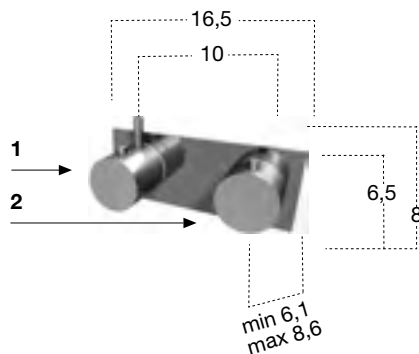

Composizione doccia 1 termostatico coassiale con apertura e chiusura acqua (1) e 1 deviatore 2 vie (2), escluso di corpo a incasso.

*Shower set 1 coaxial thermostatic with command handle (1), 1 two way diverter (2), concealed valve not included.*

H	P	L	art.
8	6,1/8,6	16,5	<b>AY654PSA</b>
8	6,1/8,6	16,5	<b>AY654PLU</b>

Corpo ad incasso per art. **AY654PSA**, art. **AY654PLU**, art. **AY654RSA** e art. **AY654RLU**.

*Concealed valve for art. **AY654PSA**, art. **AY654PLU**, art. **AY654RSA** and art. **AY654RLU**.*

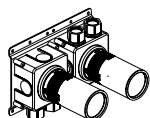

art.

**AY654INSA**

**AY654INLU**

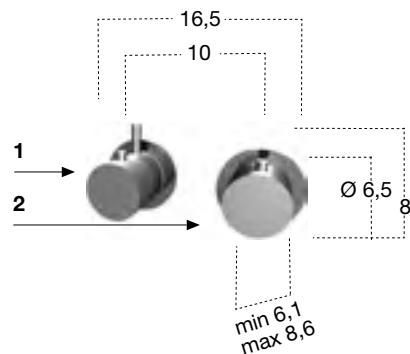

Composizione doccia 1 termostatico coassiale con apertura e chiusura acqua (1) e 1 deviatore 2 vie (2), escluso di corpo a incasso.

*Shower set 1 coaxial thermostatic with command handle (1), 1 two way diverter (2), concealed valve not included.*

H	P	L	art.
8	6,1/8,6	16,5	<b>AY654RSA</b>
8	6,1/8,6	16,5	<b>AY654RLU</b>

Corpo ad incasso per art. **AY655PSA**, art. **AY655PLU**, art. **AY655RSA** e art. **AY655RLU**.

*Concealed valve for art. **AY655PSA**, art. **AY655PLU**, art. **AY655RSA** and art. **AY655RLU**.*

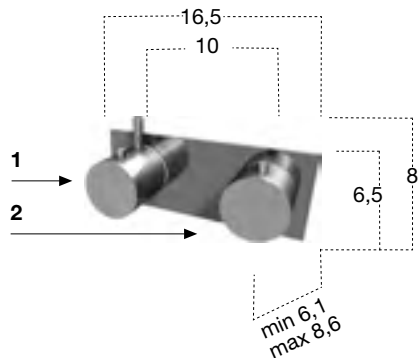
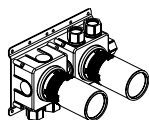

Composizione doccia 1 termostatico coassiale con apertura e chiusura acqua (1) e 1 deviatore 3 vie (2), escluso di corpo a incasso.

*Shower set 1 coaxial thermostatic with command handle (1), 1 three way diverter (2), concealed valve not included.*

H	P	H	art.
8	6,1/8,6	16,5	<b>AY655PSA</b>
8	6,1/8,6	16,5	<b>AY655PLU</b>

Corpo ad incasso per art. **AY655PSA**, art. **AY655PLU**, art. **AY655RSA** e art. **AY655RLU**.

*Concealed valve for art. **AY655PSA**, art. **AY655PLU**, art. **AY655RSA** and art. **AY655RLU**.*

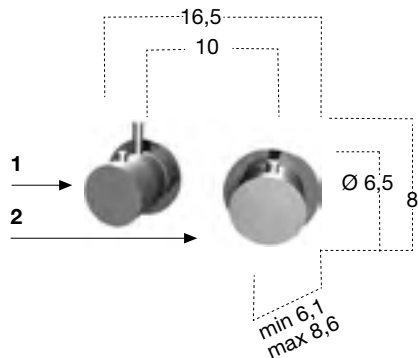
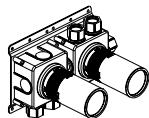

Composizione doccia 1 termostatico coassiale con apertura e chiusura acqua (1) e 1 deviatore 3 vie (2), escluso di corpo a incasso.

*Shower set 1 coaxial thermostatic with command handle (1), 1 three way diverter (2), concealed valve not included.*

H	P	L	art.
8	6,1/8,6	16,5	<b>AY655RSA</b>
8	6,1/8,6	16,5	<b>AY655RLU</b>





soffioni e rubinetteria  
overhead showers and taps

## **AYATISIMPLE** design Massimo Broglio

**Modello e design registrato**

*Registered model and design*

Realizzato in acciaio inox AISI 304, finitura satinata o lucida.  
*Made of stainless steel AISI 304, satin or polished finish.*





soffioni e rubinetteria  
overhead showers and taps



AYATISIMPLE





soffioni e rubinetteria  
overhead showers and taps

AYATISIMPLE





# AYATISIMPLE

Interamente realizzato in acciaio inox AISI 304, in finitura satinata o lucida

Made entirely of stainless steel AISI 304, satin or polished finish.

**Acciaio Satinato / Satin Stainless Steel "SA"**

**Acciaio Lucido / Polished Stainless Steel "LU"**

Canna da piano per lavabo

Top mount sink spout

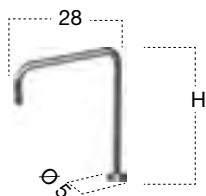

H	P	Ø	art.
35	28	5	<b>AY100QSA</b>
35	28	5	<b>AY100QLU</b>
40	28	5	<b>AY101QSA</b>
40	28	5	<b>AY101QLU</b>

Canna da piano per lavabo

Top mount sink spout



H	P	Ø	art.
40	22	5	<b>AY100CSA</b>
40	22	5	<b>AY100CLU</b>
48	22	5	<b>AY101CSA</b>
48	22	5	<b>AY101CLU</b>

Canna da terra per lavabo

Freestanding sink spout

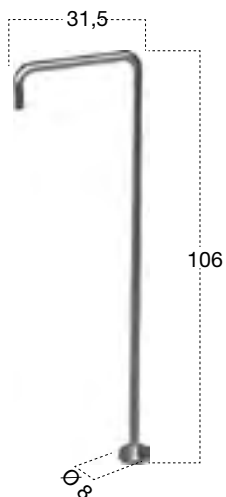

H	P	Ø	art.
106	31,5	8	<b>AY900QSA</b>
106	31,5	8	<b>AY900QLU</b>

soffioni e rubinetteria  
overhead showers and taps

Canna da terra per lavabo.

*Freestanding sink spout.*

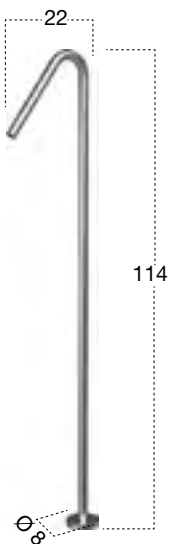

H	P	Ø	art.
114	22	8	<b>AY900CSA</b>
114	22	8	<b>AY900CLU</b>

Canna da terra per vasca.

*Freestanding bath spout.*



H	P	Ø	art.
83,5	31,5	8	<b>AY901QSA</b>
83,5	31,5	8	<b>AY901QLU</b>

Canna da terra per vasca.

*Freestanding bath spout.*

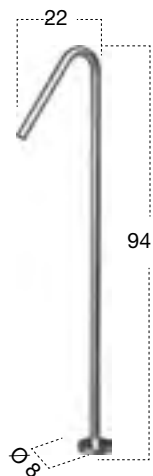

H	P	Ø	art.
94	22	8	<b>AY901CSA</b>
94	22	8	<b>AY901CLU</b>

Corpo ad incasso per art. **AY600SA**, art. **AY600LU**, art. **AY920SA**, art. **AY920LU**, art. **AY921SA**, art. **AY921LU**, art. **AY922SA** e art. **AY922LU**.

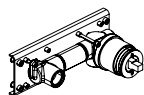

Concealed valve for art. **AY600SA**, art. **AY600LU**, art. **AY920SA**, art. **AY920LU**, art. **AY921SA**, art. **AY921LU**, art. **AY922SA** e art. **AY922LU**.

art.

**SP201INSA**

**SP201INLU**

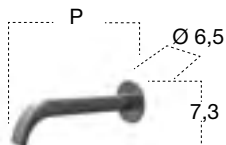

Erogatore a parete per lavabo, escluso di corpo ad incasso.

Wall mount sink spout, concealed valve not included.

H	P	Ø	art.
7,3	10	6,5	<b>AY920SA</b>
7,3	10	6,5	<b>AY920LU</b>
7,3	19,8	6,5	<b>AY921SA</b>
7,3	19,8	6,5	<b>AY921LU</b>
7,3	25,8	6,5	<b>AY922SA</b>
7,3	25,8	6,5	<b>AY922LU</b>



Miscelatore monocomando per lavabo da incasso a parete, escluso di corpo ad incasso.

Single lever sink mixer part only for wall encasing, concealed valve not included.

H	P	Ø	art.
6,8	4,5/7	6,5	<b>AY600SA</b>
6,8	4,5/7	6,5	<b>AY600LU</b>

Corpo ad incasso per art. **AY601SA** e art. **AY601LU**.

Concealed valve for art. **AY601SA** and art. **AY601LU**.

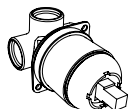

art.

**SP601INSA**

**SP601INLU**

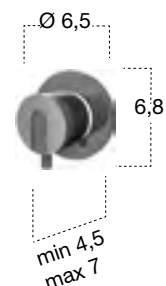

Miscelatore monocomando da incasso a parete, escluso di corpo ad incasso.

Single lever mixer for wall encasing, concealed valve not included.

H	P	Ø	art.
6,8	4,5/7	6,5	<b>AY601SA</b>
6,8	4,5/7	6,5	<b>AY601LU</b>





Corpo ad incasso per Art. AY604SA e Art. AY604LU.

*Concealed valve for Art. AY604SA and Art. AY604LU.*

art.

**SP604INSA**

**SP604INLU**

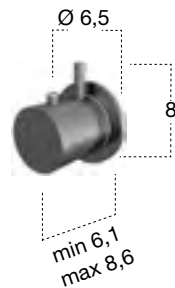

Miscelatore termostatico coassiale con apertura e chiusura acqua, escluso di corpo ad incasso.

*Coaxial thermostatic mixer with command handle, concealed valve not included.*

H	P	Ø	art.
8	6,1/8,6	6,5	<b>AY604SA</b>
8	6,1/8,6	6,5	<b>AY604LU</b>

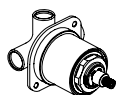

Corpo ad incasso per Art. AY602SA e Art. AY602LU.

*Concealed valve for Art. AY602SA and Art. AY602LU.*

art.

**SP602INSA**

**SP602INLU**



Deviatore incasso a due vie, escluso di corpo ad incasso.

*Encased two way diverter, concealed valve not included.*

P	Ø	art.
4,5/7	6,5	<b>AY602SA</b>
4,5/7	6,5	<b>AY602LU</b>

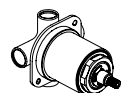

Corpo ad incasso per Art. AY603SA e Art. AY603LU

*Concealed valve for Art. AY603SA and Art. AY603LU*

art.

**SP603INSA**

**SP603INLU**



Deviatore incasso a tre vie, escluso di corpo ad incasso.

*Encased three way diverter, concealed valve not included.*

P	Ø	art.
4,5/7	6,5	<b>AY603SA</b>
4,5/7	6,5	<b>AY603LU</b>

Composizione doccia 2 miscelatori.

*Shower set 2 mixers.*



+

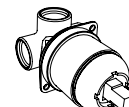
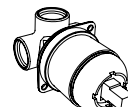

art.

**AY601SA**

**AY601LU**

art.

**AY601SA**

**AY601LU**

art.

**SP601INSA**

**SP601INLU**

art.

**SP601INSA**

**SP601INLU**

Composizione doccia 3 miscelatori.

*Shower set 3 mixers.*



+

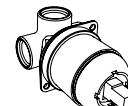
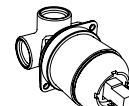
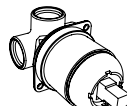

art.

**AY601SA**

**AY601LU**

art.

**AY601SA**

**AY601LU**

art.

**AY601SA**

**AY601LU**

art.

**SP601INSA**

**SP601INLU**

art.

**SP601INSA**

**SP601INLU**

art.

**SP601INSA**

**SP601INLU**

Composizione doccia 1 miscelatore termostatico e 1 deviatore a 2 vie.

*Shower set 1 thermostatic mixer and 1 2-way diverter.*



+

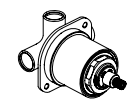

art.

**AY604SA**

**AY604LU**

art.

**AY602SA**

**AY602LU**

art.

**SP604INSA**

**SP604INLU**

art.

**SP602INSA**

**SP602INLU**

Composizione doccia 1 miscelatore termostatico e 1 deviatore a 3 vie.

*Shower set 1 thermostatic mixer and 1 3-way diverter.*



+

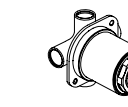

art.

**AY604SA**

**AY604LU**

art.

**AY603SA**

**AY603LU**

art.

**SP604INSA**

**SP604INLU**

art.

**SP603INSA**

**SP603INLU**

**BIKAPPA** design Carlo Colombo - AL Studio

Realizzata in ottone con finitura cromo lucido.  
*Produced in brass with a polished chrome finish.*





# BIKAPPA

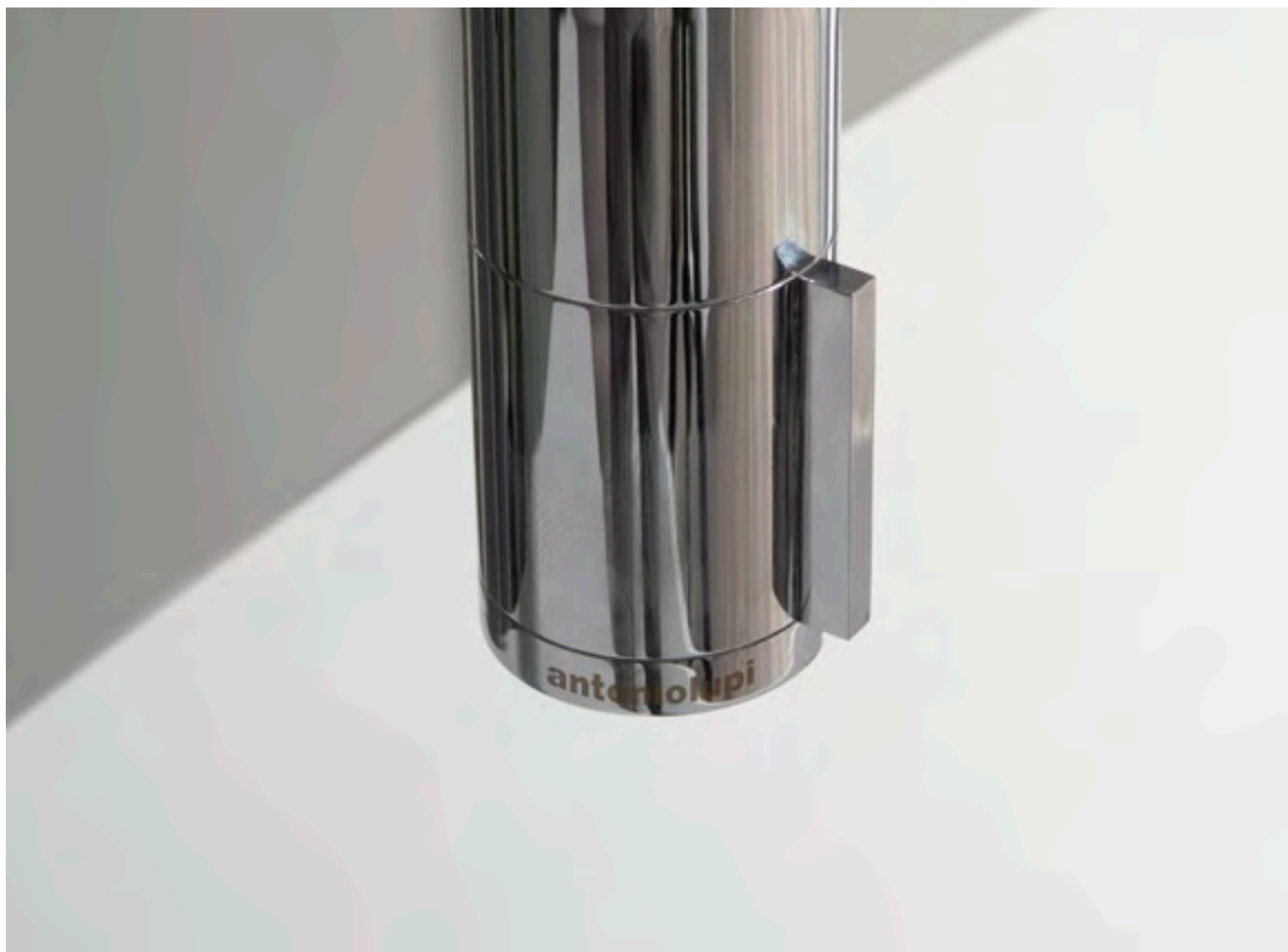

art. BK906N/BK907N/BK908/BK909N

soffioni e rubinetteria  
overhead showers and taps

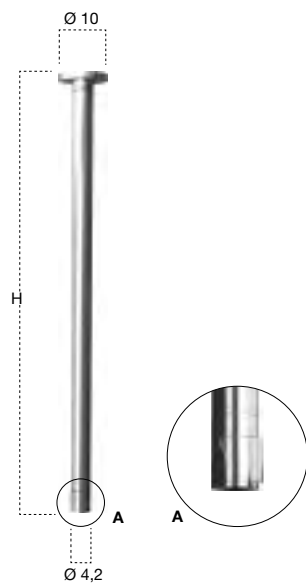

art. BK906I



art.  
**BK906I**

Corpo ad incasso per art. BK906N, art. BK907N, art. BK908N e art. BK909N.

*Concealed valve for art. BK906N, art. BK907N, art. BK908N and art. BK909N.*

art.	Ø	H
<b>BK906N</b>	10	120 cm
<b>BK907N</b>	10	130 cm
<b>BK908N</b>	10	140 cm
<b>BK909N</b>	10	150 cm

Colonna da soffitto per lavabo con sistema di comando progressivo, escluso di corpo a incasso.

*Ceiling mounted basin mixer with progressive mixer control, concealed valve not included.*



# BIKAPPA



art. BK200N / BK201N

soffioni e rubinetteria  
overhead showers and taps

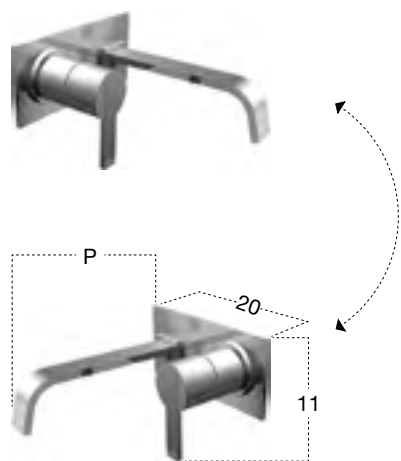

art. BK201I



art.  
BK201I

Corpo ad incasso reversibile per art. BK200N e art. BK201N.

*Reversible concealed valve for art. BK200N and art. BK201N.*

art.	P	L	H
BK200N	20	20	11 cm
BK201N	25	20	11 cm

Monocomando reversibile a parete per lavabo, escluso di corpo ad incasso.

*Reversible single lever wall mount sink mixer, concealed valve not included.*





# BIKAPPA



art. BK400N

art. BK400PR

soffioni e rubinetteria  
overhead showers and taps

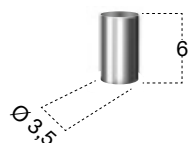
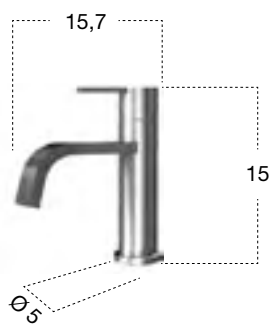

art.	H	P	Ø
<b>BK400N</b>	15	15,7	5 cm

Monocomando da piano per lavabo o bidet.

*Single lever sink mixer for sink or bidet.*

art.	H	Ø
<b>BK400PR</b>	6	3,5 cm

Prolunga H 6 cm per art. BK400N.

*Extension 6 cm H for art. BK400N.*





# BIKAPPA



art. BK300N

art. BK904N

art. BK905N

art. BK905PR

soffioni e rubinetteria  
overhead showers and taps

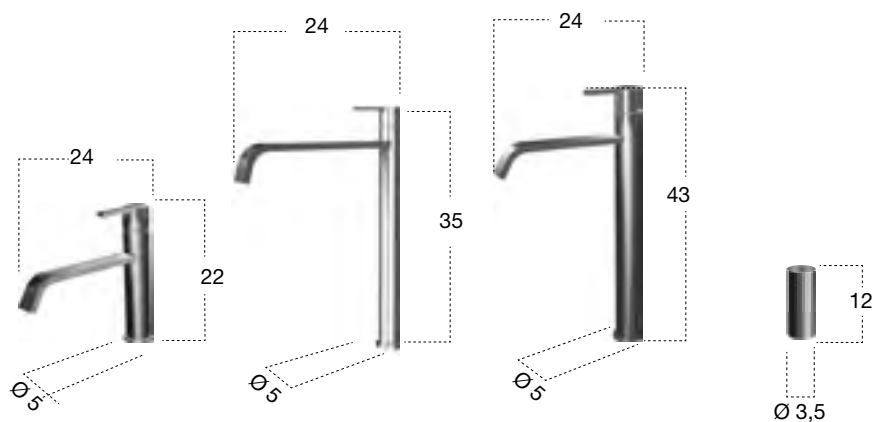

art.	H	P	Ø
<b>BK300N</b>	22	24	5 cm
<b>BK904N</b>	35	24	5 cm
<b>BK905N</b>	43	24	5 cm

Monocomando da piano per lavabo.

Single lever sink mixer.

art.	H	Ø
<b>BK905PR</b>	12	3,5 cm

Prolunga H 12 cm per art. BK905N.

Extension 12 cm H for art. BK905N.

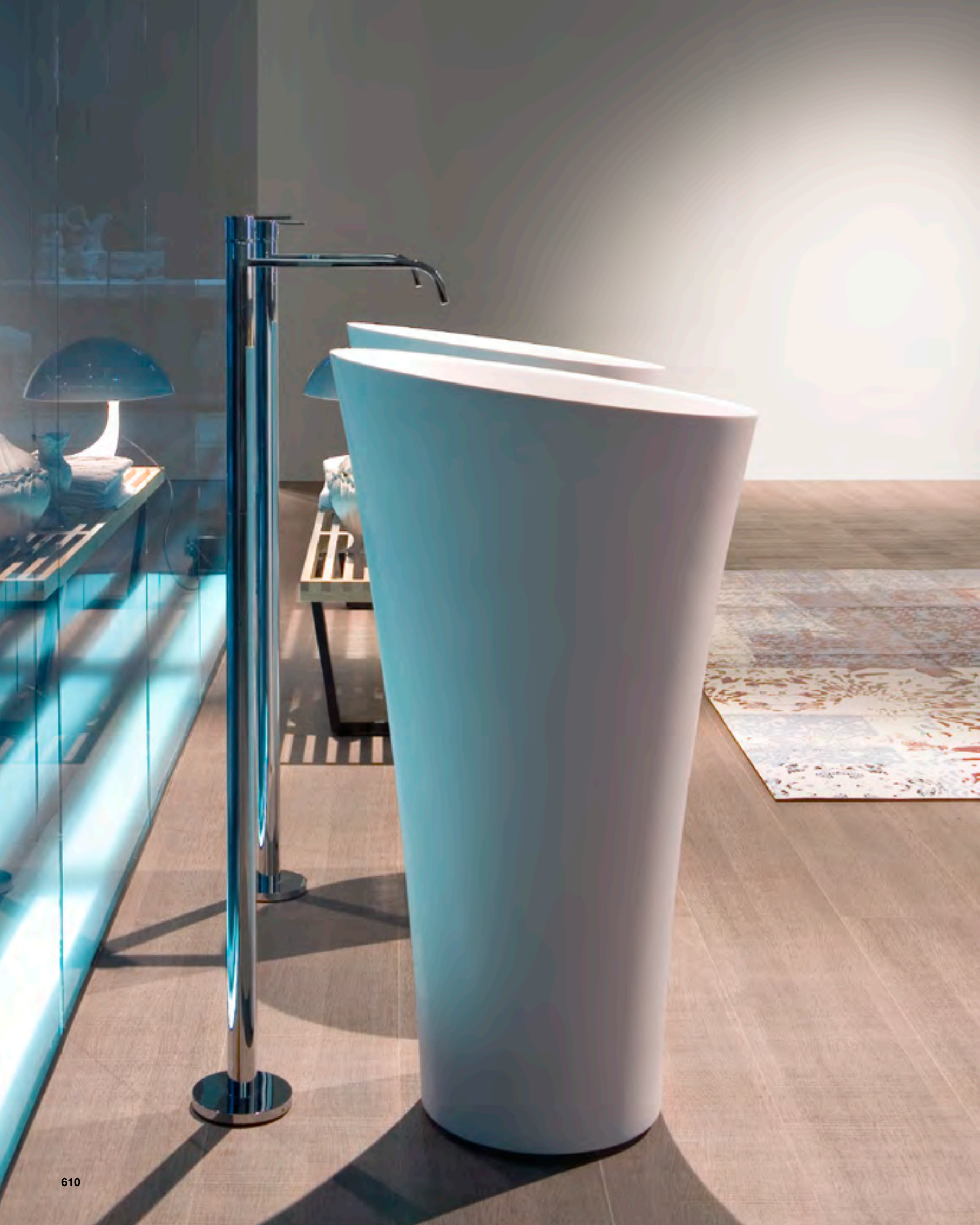



# BIKAPPA



art. BK902N

soffioni e rubinetteria  
overhead showers and taps



art. BK903IN



art.  
BK903IN

Corpo ad incasso per art. BK902N e art. BK903N.

*Concealed valve for art. BK902N and art. BK903N.*

art.	H	P	Ø
BK902N	110	29,5	10 cm

Monocomando da terra per lavabo, escluso di corpo a incasso.

*Freestanding single lever sink mixer, concealed valve not included.*







art. BK903N

soffioni e rubinetteria  
overhead showers and taps

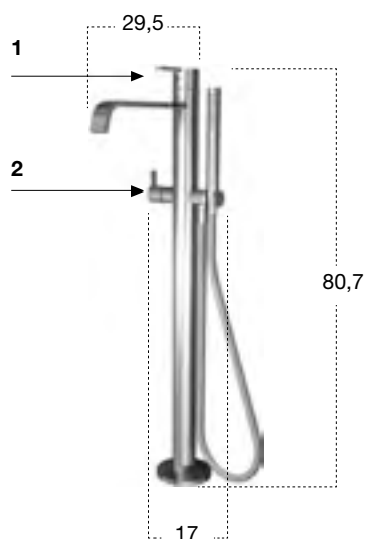

art. BK903IN



art.  
BK903IN

Corpo ad incasso per art. BK902N e art. BK903N.

Concealed valve for art. BK902N and art. BK903N.

art.	H	P	L
BK903N	80,7	29,5	17 cm

Colonna da terra per vasca, completa di miscelatore per erogatore (1), miscelatore per doccetta (2), doccetta con flessibile 150 cm, escluso di corpo a incasso.

Freestanding bath mixer complete with single lever for spout (1) shower mixer (2) hand shower with hose 150 cm. concealed valve not included.





# BIKAPPA



soffioni e rubinetteria  
overhead showers and taps

art. BK702

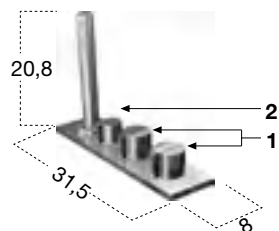

art.	H	P	L
<b>BK702</b>	20,8	8	31,5 cm

Gruppo bordo vasca completo di rubinetti di comando acqua calda e fredda (1), miscelatore per doccia (2) e doccia con flessibile 150 cm a scomparsa.

*Bath rim set complete with hot and cold water handles (1), shower mixer (2) and hand shower with hidden hose 150 cm.*



# BIKAPPA



art. BK701

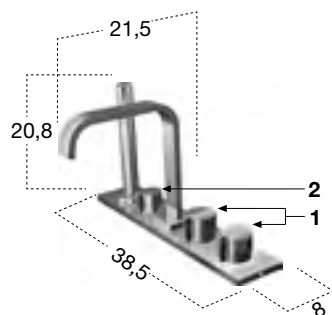

art.	H	P	L
<b>BK701</b>	20,8	21,5	38,5 cm

Gruppo bordo vasca completo di erogatore, rubinetti di comando acqua calda e fredda (1), miscelatore per doccia (2) e doccia con flessibile 150 cm a scomparsa.

*Bath rim set complete with spout, hot and cold water handles (1), shower mixer (2) and hand shower with hidden hose 150 cm.*





# BIKAPPA



art. BK602

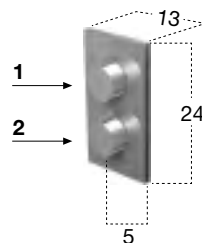

art. BK602I



art.  
BK602I

Corpo ad incasso per Art. BK602.

*Concealed valve for Art. BK602.*

art.	H	P	L
BK602	24	5	13 cm

Gruppo doccia da incasso parete con miscelatore termostatico (2) e rubinetto di comando con deviatore a due vie (1), escluso di corpo ad incasso.

*Encased mixer with thermostat (2) command handle with two-way diverter (1), concealed valve not included.*

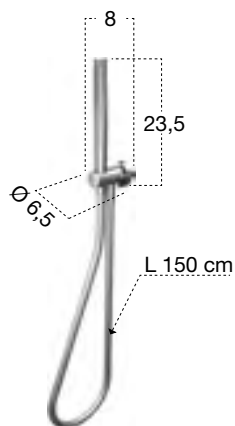

art.	H	P	L
BK150	23,5	8	6,5 cm

Doccetta completa di supporto e presa d'acqua a parete con flessibile 150 cm.

*Hand shower with hose cm 150, wall outlet and holder.*

art. BK603

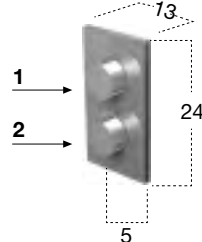

art. BK603I



art.  
BK603I

Corpo ad incasso per Art. BK603.

*Concealed valve for Art. BK603.*

art.	H	P	L
BK603	24	5	13 cm

Gruppo doccia da incasso parete con miscelatore termostatico (2), rubinetto di comando con deviatore a tre vie (1), escluso di corpo ad incasso.

*Encased mixer with thermostat (1) command handle and three-way diverter (2), concealed valve not included.*







# BIKAPPA



art. BK151

art. BK152

soffioni e rubinetteria  
overhead showers and taps

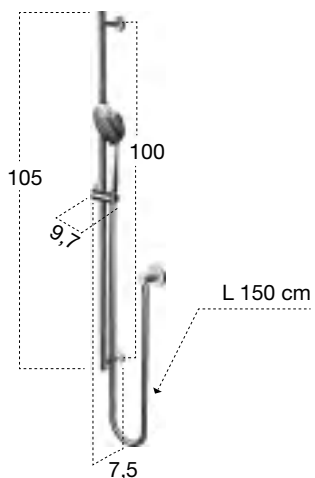
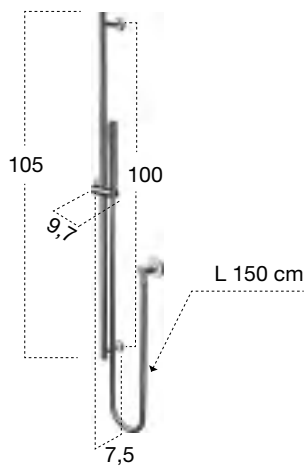

art.	H	P	L
<b>BK151</b>	105	7,5	9,7 cm

Doccetta biuso completa di asta scorrevole e presa d'acqua separata a parete con flessibile 150 cm.

*Hand shower complete with bar and separate wall mount water intake with flexible hose 150 cm.*

art.	H	P	L
<b>BK152</b>	105	7,5	9,7 cm

Doccetta biuso completa di asta scorrevole e presa d'acqua separata a parete con flessibile 150 cm.

*Hand shower complete with bar and separate wall mount water intake with flexible hose 150 cm.*



# BIKAPPA

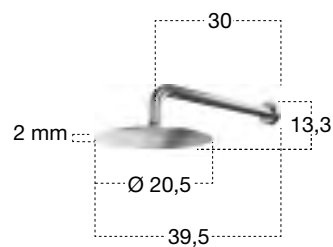

art.	H	P	Ø
<b>BK665</b>	13,3	39,5	20,5 cm

Soffione ultrasottile per doccia con braccio a parete.

*Ultra-thin overhead shower with arm.*

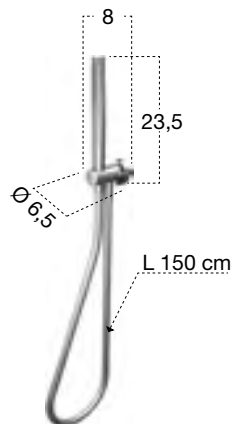

art.	H	P	L
<b>BK150</b>	23,5	8	6,5 cm

Doccetta completa di supporto e presa d'acqua a parete con flessibile 150 cm.

*Hand shower with hose cm 150, wall outlet and holder.*

art. **BK616**

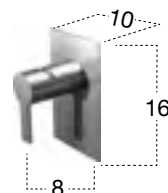

art. **BK601I**



art. **BK601I**

Corpo ad incasso per Art. BK601 e Art. BK616.

*Concealed valve for Art. BK601 and Art. BK616.*

art.	H	P	L
<b>BK616</b>	16	8	10 cm

Monocomando da incasso parete, escluso di corpo ad incasso.

*Encased mixer, concealed valve not included.*

art. **BK601**

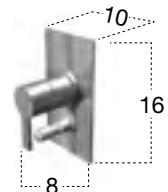

art. **BK601I**



art. **BK601I**

Corpo ad incasso per Art. BK601 e Art. BK616.

*Concealed valve for Art. BK601 and Art. BK616.*

art.	H	P	L
<b>BK601</b>	16	8	10 cm

Monocomando da incasso parete con deviatore, escluso di corpo ad incasso.

*Encased mixer with diverter, concealed valve not included.*



soffioni e rubinetteria  
overhead showers and taps



**TIMBRO** design Roberto Lazzeroni

Realizzato in ottone con finitura cromo lucido.  
*Produced in brass with a polished chrome finish.*





soffioni e rubinetteria  
overhead showers and taps





TIMBRO



soffioni e rubinetteria  
overhead showers and taps





## TIMBRO



soffioni e rubinetteria  
overhead showers and taps





# TIMBRO



soffioni e rubinetteria  
overhead showers and taps



# TIMBRO

Realizzato in ottone con finitura cromo lucido.  
Produced in brass with a polished chrome finish.

Gruppo 3 fori da piano per bidet completo di erogatore e rubinetti di comando acqua calda e fredda.

*3 hole bidet mixer complete with spout and command handles for hot and cold water.*

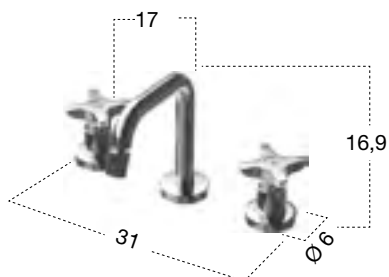

H	P	L	art.
16,9	17	31	<b>TB431</b>

Corpo ad incasso per art. **TB432**

*Concealed valve for art. **TB432***

art.

**TB231IN**

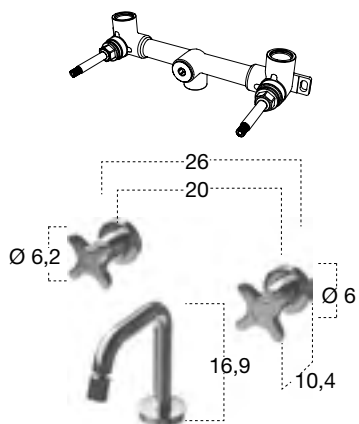

Erogatore per bidet completo di rubinetti di comando acqua calda e fredda, escluso di corpo ad incasso.

*Bidet spout complete with command handles for hot and cold water, concealed valve not included.*

H	P	L	art.
16,9	17	26	<b>TB432</b>

Gruppo 3 fori da piano per lavabo completo di erogatore e rubinetti di comando acqua calda e fredda.

*3 hole sink mixer complete with spout and command handles for hot and cold water.*

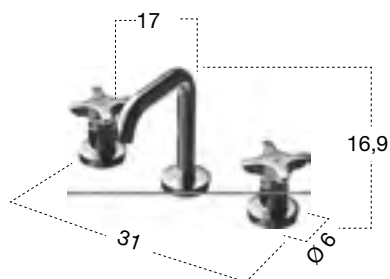

H	P	L	art.
16,9	17	31	<b>TB430</b>

Corpo ad incasso per art. **TB230** e art. **TB231**

*Concealed valve for art. **TB230** and art. **TB231***

art.

**TB231IN**

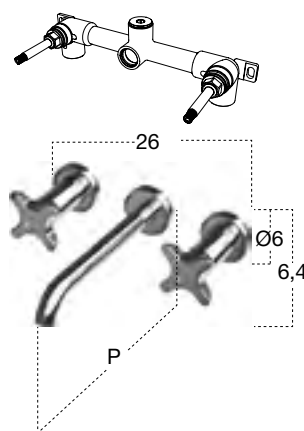

Gruppo lavabo a parete completo di erogatore e rubinetti di comando acqua calda e fredda, escluso di corpo ad incasso.

*Wall mount sink set complete with spout and hot and cold handles, concealed valve not included.*

H	P	L	art.
6,4	19,8	26	<b>TB230</b>
6,4	25,8	26	<b>TB231</b>



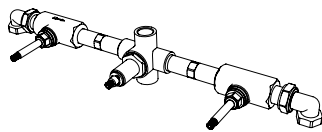

Corpo ad incasso per art. **TB730**

Concealed valve for art. **TB730**

art.

**TB730IN**

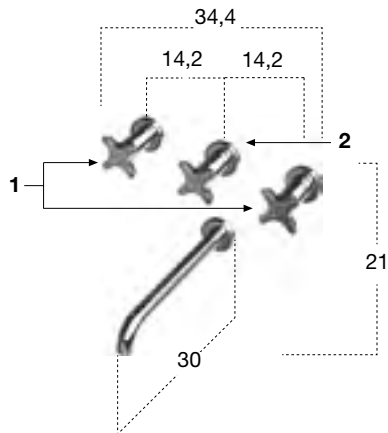

Gruppo vasca a parete completo di erogatore e rubinetti di comando acqua calda e fredda (1) e 1 deviatore 2 vie (2), escluso di corpo ad incasso.

Bathtub mixer set complete with spout and hot and cold command handles (1) and 1 2-way diverter (2), concealed valve not included.

H	P	L	art.
21	30	34,4	<b>TB730</b>

Colonna da terra per vasca, completa di erogatore e rubinetti di comando acqua calda e fredda (1), deviatore per doccia (2) e doccia con flessibile 150 cm.

Freestanding bath column complete with spout and command handles (1), hand shower diverter (2) and hand shower with flexible hose 150 cm.

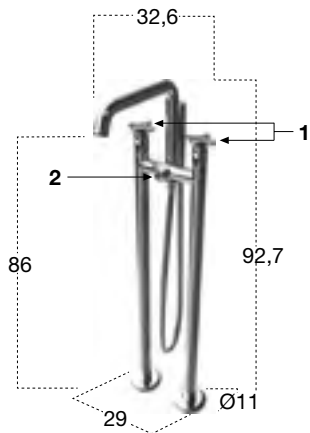

H	P	L	art.
92,7	32,6	29	<b>TB933</b>

Doccetta completa di supporto e presa d'acqua a parete con flessibile 150 cm.

Hand shower with hose 150 cm, wall outlet and holder.

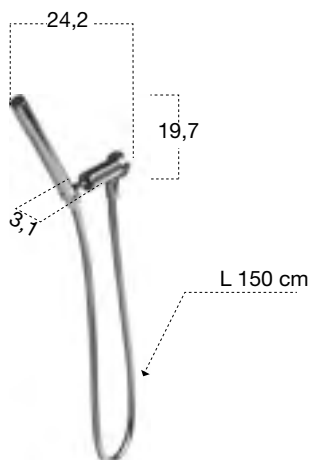

H	P	L	art.
19,7	24,2	3,1	<b>TB150</b>

Doccetta biuso completa di asta scorrevole e presa acqua separata a parete con flessibile 150 cm.

*Hand shower complete with bar and separate wall mount water intake with flexible hose 150 cm.*

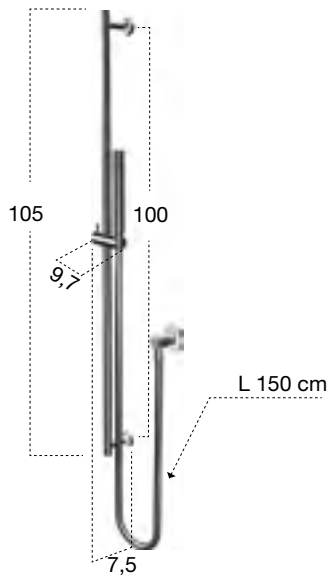

H	P	L	art.
105	7,5	9,7	<b>BK151</b>

Corpo ad incasso per art. **TB631**.

*Concealed valve for art. TB631.*

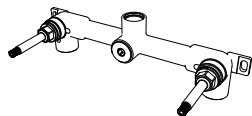

art.  
**TB231IN**

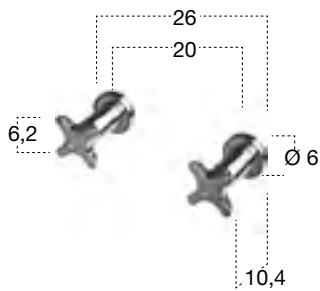

Composizione doccia con rubinetti di comando acqua calda e fredda, escluso di corpo ad incasso.

*Shower set of hot and cold water command handles, concealed valve not included.*

H	P	L	art.
6,2	10,4	26	<b>TB631</b>

Corpo ad incasso per art. **TB682**.

*Concealed valve for art. TB682.*

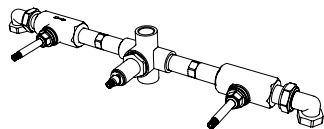

art.  
**TB730IN**

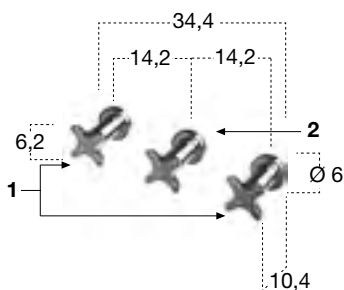

Composizione doccia con rubinetti di comando acqua calda e fredda (1) e 1 deviatore 2 vie (2), escluso di corpo ad incasso.

*Shower set of hot and cold water command handles (1) and 1 2-way diverter (2), concealed valve not included.*

H	P	L	art.
6,2	10,4	34,4	<b>TB682</b>

Corpo ad incasso per art.**TB601**, art.**TB602** e art.**TB603**.

*Concealed valve for art. **TB601**, art. **TB602** and art. **TB603**.*



art.

**TB602IN**

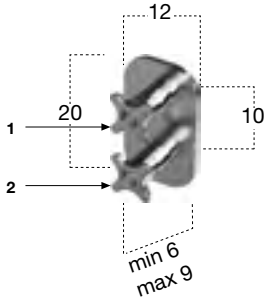

Gruppo doccia da incasso a parete con miscelatore termostatico (2) e rubinetto di comando (1), escluso di corpo ad incasso.

*Encased shower set with thermostatic mixer (2) and command handle (1), concealed valve not included.*

H	P	L	art.
20	6/9	12	<b>TB601</b>

Corpo ad incasso per art.**TB601**, art.**TB602** e art.**TB603**.

*Concealed valve for art. **TB601**, art. **TB602** and art. **TB603**.*



art.

**TB602IN**

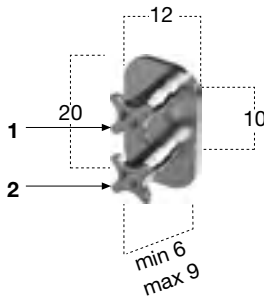

Gruppo doccia da incasso parete con miscelatore termostatico (2) e rubinetto di comando con deviatore a due vie (1), escluso di corpo ad incasso.

*Encased mixer with thermostat (2) command handle with two-way diverter (1), concealed valve not included.*

H	P	L	art.
20	6/9	12	<b>TB602</b>

Corpo ad incasso per art.**TB601**, art.**TB602** e art.**TB603**.

*Concealed valve for art. **TB601**, art. **TB602** and art. **TB603**.*



art.

**TB602IN**

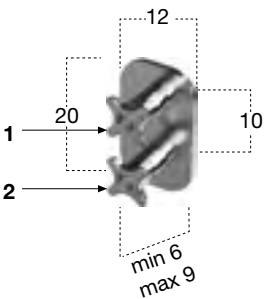

Gruppo doccia da incasso parete con miscelatore termostatico (2) e rubinetto di comando con deviatore a tre vie (1), escluso di corpo ad incasso.

*Encased mixer with thermostat (2) command handle with three-way diverter (1), concealed valve not included.*

H	P	L	art.
20	6/9	12	<b>TB603</b>





**SPECCHIERE E ILLUMINAZIONE**  
**MIRRORS AND LIGHTING**





L da 54 cm a 216 cm  
*from 54 cm to 216 cm*

art.**NEUTRO50** H 50 cm  
art.**NEUTRO75** H 75 cm  
art.**NEUTRO90** H 90 cm  
art.**NEUTRO100** H 100 cm  
art.**NEUTRO110** H 110 cm

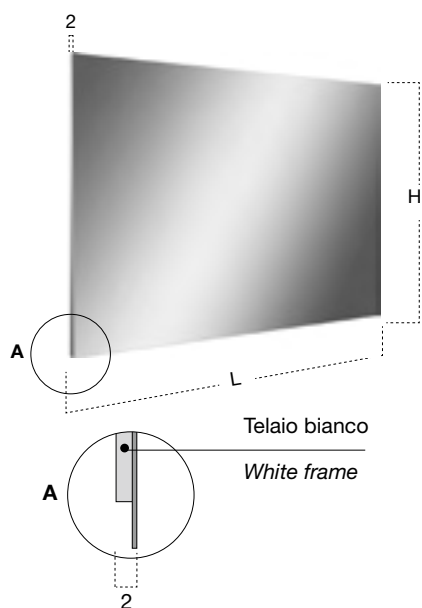

Specchio a filo lucido completo di telaio bianco.  
*Polished edge mirror with white frame.*



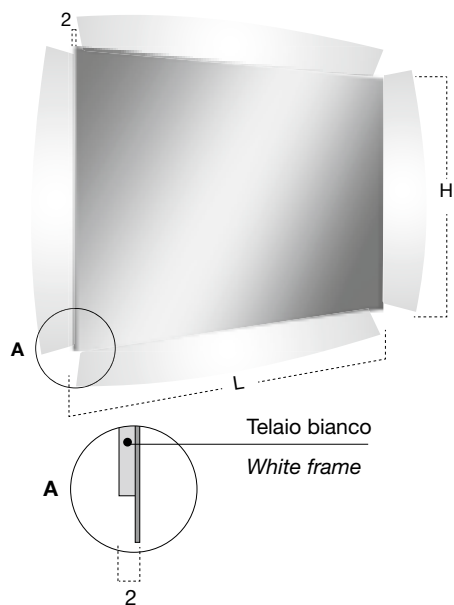

H	L	art.
50	da 54 cm a 216 cm <i>from 54 cm to 216 cm</i>	<b>NEUTROLED50W</b>
75	da 54 cm a 216 cm <i>from 54 cm to 216 cm</i>	<b>NEUTROLED75W</b>
90	da 54 cm a 216 cm <i>from 54 cm to 216 cm</i>	<b>NEUTROLED90W</b>
100	da 54 cm a 216 cm <i>from 54 cm to 216 cm</i>	<b>NEUTROLED100W</b>
110	da 54 cm a 216 cm <i>from 54 cm to 216 cm</i>	<b>NEUTROLED110W</b>

Specchio a filo lucido con illuminazione a led luce bianca, completo di trasformatore remoto e telaio bianco.

*Polished edge mirror with white led lighting, complete with remote transformer and white frame.*

specchiere e illuminazione  
mirrors and lighting

Tutte le specchiere vengono fornite con luce a LED  
bianca a 4000 Kelvin.

*All mirrors are provided with white LED lighting at  
4000 Kelvin.*





Su richiesta è possibile avere luce a LED bianca più calda a 3000 Kelvin, senza costi aggiuntivi.

*Upon request it is possible to request warmer white LED lighting at 3000 Kelvin without additional surcharges.*



specchiere e illuminazione  
mirrors and lighting





**Interruttore di comando accensione per specchiere con telaio in acciaio AISI 304. I numeri cerchiati indicano le diverse possibilità di posizionamento dell'interruttore.**

**Lighting control device for mirrors with frame in steel AISI 304. The circled numbers indicate the different possible position such.**

Sistema di comando per apparecchi luminosi con carico massimo 550W per un massimo di tre interruttori con funzione deviatore (quindi da ogni interruttore si può accendere e/o spegnere l'impianto luminoso) con l'innovativa tecnologia **touch led** (il comando viene attivato e disattivato al tocco del led luminoso).

Luce di segnalazione nell'interruttore con intensità che varia in base alla luce dell'ambiente con funzione crepuscolare al calare della luce ambiente il Led interruttore aumenterà automaticamente la sua luminosità (luce di cortesia) mentre al contrario all'aumento della luminosità dell'ambiente rientrerà automaticamente in posizione day.

La luminosità dell'interruttore Led di segnalazione può essere modificata per stare sempre in condizione day e quindi senza funzione crepuscolare, basterà coprire con il dito l'interruttore Led per tre secondi circa affinché non si noteranno degli impulsi di luce. In questa condizione il Led luminoso anche alla diminuzione dell'intensità della luce ambiente rimarrà sempre in posizione day. Ripetendo questa operazione il led interruttore ritornerà nella posizione 1 day and night.

*Lighting control device with a maximum operating voltage of 550 W for no more than three switches with diverting functions (from each switch turn on/off the lighting system) with the innovative technology of **touch led** (touch switch operated).*

*Nightlight function is activated automatically when it becomes dark. It will transform from its dim stand-by mode to a full light mode and will automatically deactivate when the room becomes bright.*

*The nightlight function may be deactivated if not desired. This is achieved by one long touch to the Led switch for at least 3 seconds until it gives off a very subtle glow. If this action is repeated you will return to position 1 night and day.*



**H 50**

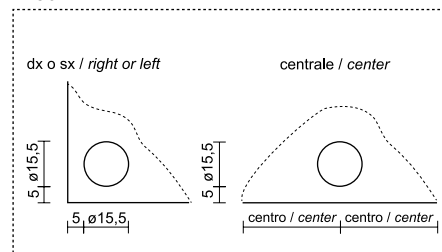

**H 75/100/110**

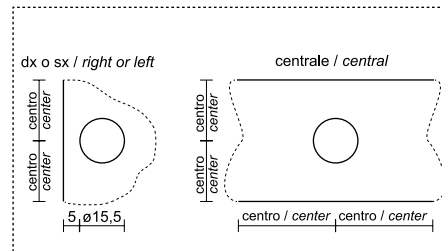

Specchio ingranditore 2x ø 155 mm per inserimento a dx, sx o centrale su specchi a filo lucido di forma quadrata o rettangolare.

**N.B.** Questo articolo viene posizionato sullo specchio a misure prestabilite secondo l'altezza scelta. Per inserimento su articoli o misure diverse da quelle indicate si prega di consultare l'azienda.

*Magnifying mirror 2x ø 155 mm to be installed on the left, right or center of any square or rectangular polished edge mirror.*

**P.S.** This art. comes installed using pre-established measurements which depend on the height ordered. For installation different than indicated please consult the Company.





# FLASH



H	L	art.
50	da 72 cm a 216 cm <i>from 72 cm to 216 cm</i>	<b>FLASH50W / FLASH50L</b>
75	da 72 cm a 216 cm <i>from 72 cm to 216 cm</i>	<b>FLASH75W / FLASH75L</b>
90	da 72 cm a 216 cm <i>from 72 cm to 216 cm</i>	<b>FLASH90W / FLASH90L</b>
100	da 72 cm a 216 cm <i>from 72 cm to 216 cm</i>	<b>FLASH100W / FLASH100L</b>

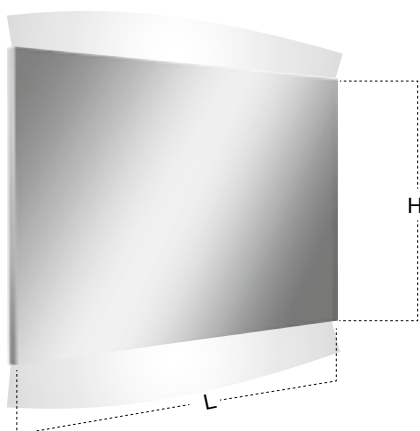

Specchio a filo lucido con illuminazione a led luce bianca o bianca e blu, completo di telaio in acciaio lucido AISI 304.

*Polished edge mirror with white or white and blue led lighting, complete with polished steel frame AISI 304.*



# FLASH



H	L	art.
125	da 72 cm a 216 cm <i>from 72 cm to 216 cm</i>	<b>FLASH125W / FLASH125L</b>
150	da 72 cm a 216 cm <i>from 72 cm to 216 cm</i>	<b>FLASH150W / FLASH150L</b>

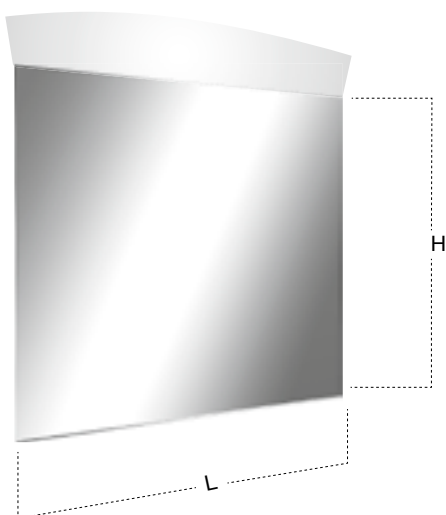

Specchio a filo lucido con illuminazione a led luce bianca o bianca e blu solo nella parte superiore, completo di telaio in acciaio lucido AISI 304.

*Polished edge mirror with white or white and blue led lighting only from the upper side, complete with polished steel frame AISI 304.*









H	L	art.
50	da 72 cm a 216 cm <i>from 72 cm to 216 cm</i>	<b>LAMPO50W / LAMPO50L</b>
75	da 72 cm a 216 cm <i>from 72 cm to 216 cm</i>	<b>LAMPO75W / LAMPO75L</b>

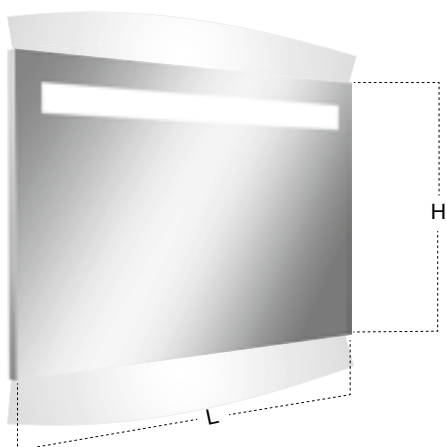

Specchio a filo lucido con illuminazione a led luce bianca o bianca e blu, completo di telaio in acciaio lucido AISI 304.

*Polished edge mirror with white or white and blue led lighting, complete with polished steel frame AISI 304.*



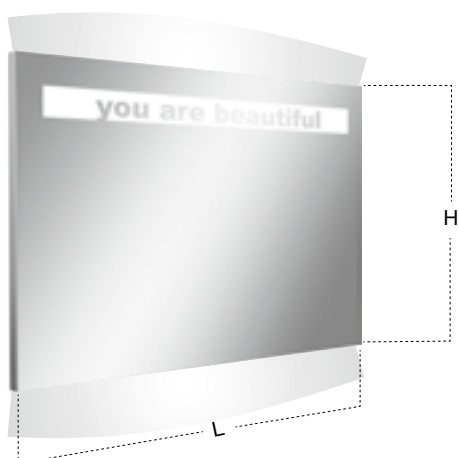

H L  
 50 da 72 cm a 216 cm  
 from 72 cm to 216 cm  
 75 da 72 cm a 216 cm  
 from 72 cm to 216 cm

**art.**  
**TALK50W / TALK50L**  
**TALK75W / TALK75L**

Scritta decorativa / decorative writing

- L 72/81/90 you are here
- L 99/108/117 you are beautiful
- L 126/135/144/153 you are what you think
- L 162/171 the future's in the mirror
- L 180 the truth is that the truth changes
- L 189/198/207/216 if you can't be the sky, be a bird

Specchio a filo lucido con illuminazione a led luce bianca o bianca e blu, completo di telaio in acciaio lucido AISI 304 e scritta decorativa.

*Polished edge mirror with white or white and blue led lighting, complete with polished steel frame AISI 304 and decorative writing.*

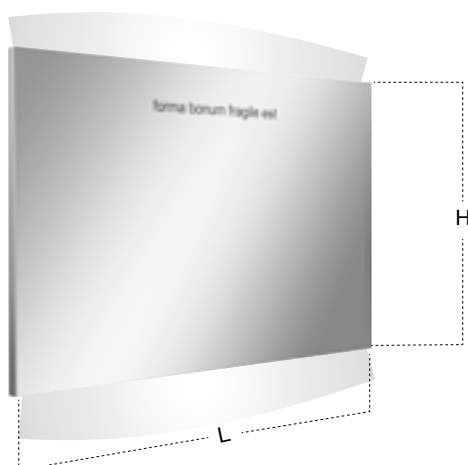

H	L
50	da 72 cm a 216 cm from 72 cm to 216 cm
75	da 72 cm a 216 cm from 72 cm to 216 cm

**art.**  
**OVIDIO50W / OVIDIO50L**

**OVIDIO75W / OVIDIO75L**

Scritta illuminata / illuminated writing

L 72/81/90

omnia mutantur

L 99/108/117

forma bonum fragile est

L 126/135/144/153

res est solliciti plena timoris amor

L 162/171

quid sit futurus cras, fuge quaerere

L 180

acta exteriora indicant interiora secreta

L 189/198/207/216

in nova fert animus mutatas dicere formas corpora

Specchio a filo lucido con illuminazione a led luce bianca o bianca e blu, completo di telaio in acciaio lucido AISI 304 e scritta decorativa.

Polished edge mirror with white or white and blue led lighting, complete with polished steel frame AISI 304 and decorative writing.







art. DAMA108 / DAMA108W / DAMA108L

art. DAMA75 / DAMA75W / DAMA75L

H	L
108	108

art. **DAMA108 / DAMA108W / DAMA108L**

75	da 90 cm a 216 cm from 90 cm to 216 cm
----	---

**DAMA75 / DAMA75W / DAMA75L**

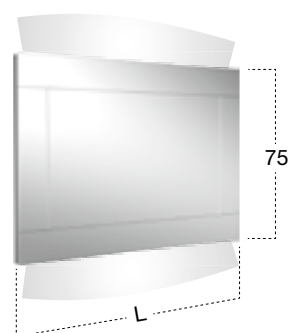
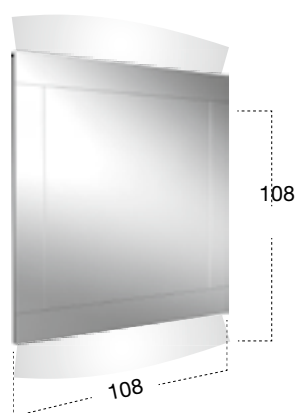

Specchio a filo lucido con o senza illuminazione a led luce bianca o bianca e blu, completo di telaio in acciaio lucido AISI 304 e cornice a disegno.

*Polished edge mirror with or without white or white and blue led lighting, complete with polished steel frame AISI 304.*

specchiere e illuminazione  
mirrors and lighting





H	L	art.
50	da 72 cm a 216 cm <i>from 72 cm to 216 cm</i>	<b>SPIO150W / SPIO150L</b>
75	da 72 cm a 216 cm <i>from 72 cm to 216 cm</i>	<b>SPIO175W / SPIO175L</b>

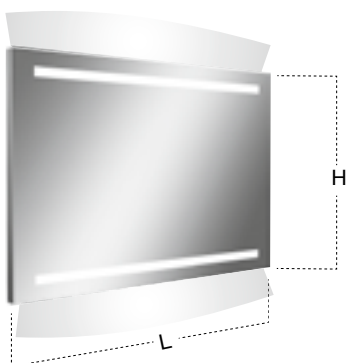

Specchio a filo lucido con illuminazione a led luce bianca o bianca e blu, completo di telaio in acciaio lucido AISI 304.

*Polished edge mirror with white or white and blue led lighting, complete with polished steel frame AISI 304.*



# SPIO



H	L	art.
50	da 90 cm a 216 cm <i>from 90 cm to 216 cm</i>	<b>SPIO250W</b>
75	da 90 cm a 216 cm <i>from 90 cm to 216 cm</i>	<b>SPIO275W</b>

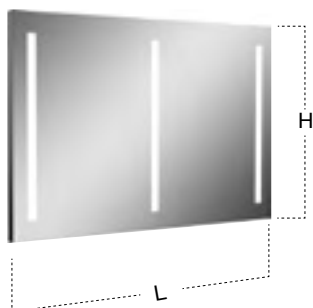

Specchio a filo lucido con illuminazione a led luce bianca e telaio in acciaio lucido AISI 304.  
*Polished edge mirror with white led lighting complete with polished steel frame AISI 304.*



L H art.  
36 108 **SPIO4W**

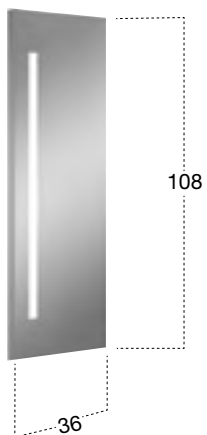

Versione sx / Left version

Specchio dx o sx a filo lucido con illuminazione a led luce bianca completo di telaio in acciaio lucido AISI 304.

*Polished edge mirror, right or left, with white led lighting complete with polished stainless steel frame AISI 304.*

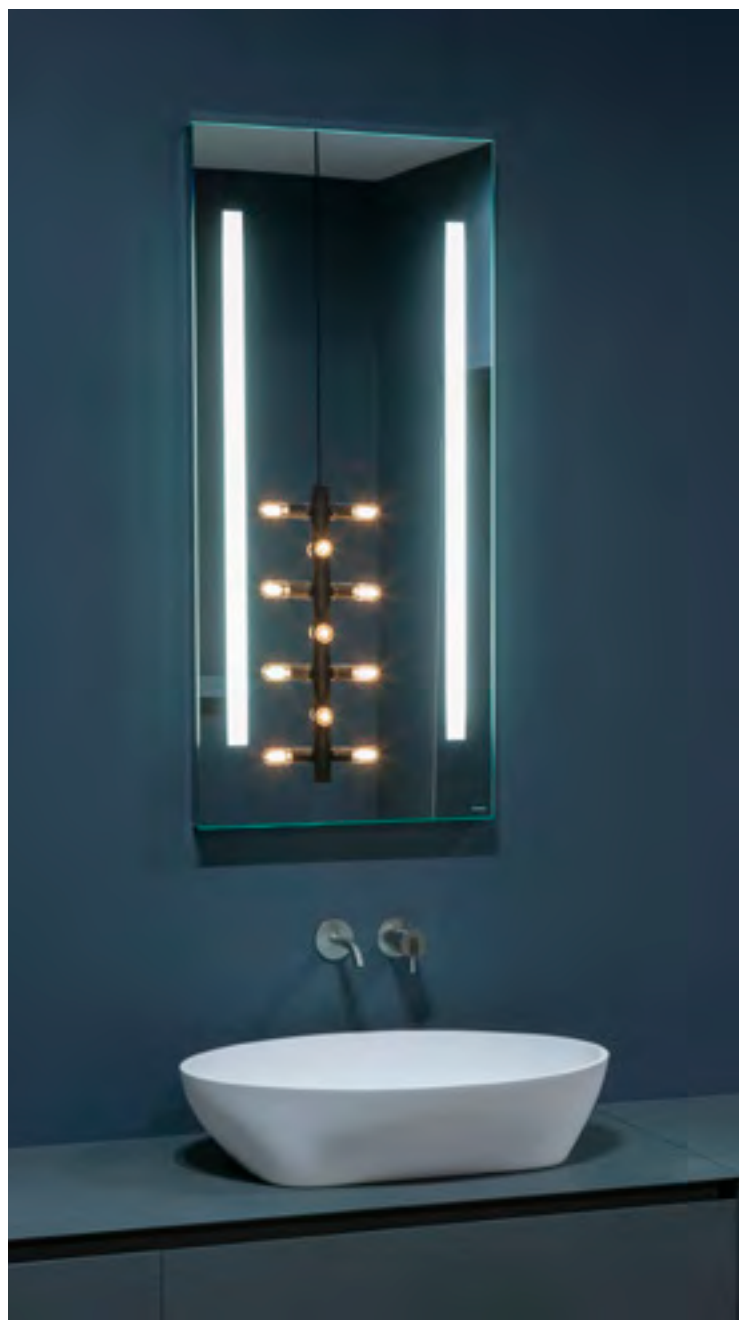

L H art.  
50 108 **SPIO5W**

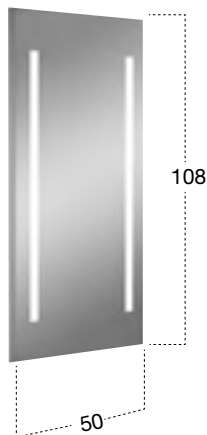

Specchio a filo lucido con illuminazione a led luce bianca completo di telaio in acciaio lucido AISI 304.

*Polished edge mirror with white led lighting complete with polished stainless steel frame AISI 304.*

specchiere e illuminazione  
mirrors and lighting

# SPIO



H	L	art.
50	da 72 cm a 216 cm <i>from 72 cm to 216 cm</i>	<b>SPIO50W</b>
75	da 72 cm a 216 cm <i>from 72 cm to 216 cm</i>	<b>SPIO75W</b>

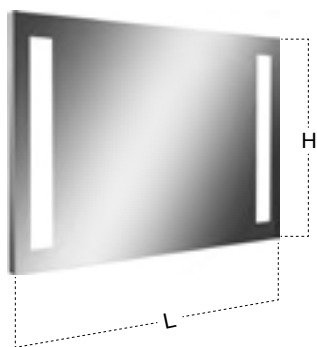

Specchio a filo lucido con illuminazione a led luce bianca completo di telaio in acciaio lucido AISI 304.

*Polished edge mirror with white led lighting complete with polished stainless steel frame AISI 304.*



# SPIO



L	H	art.
50	90	<b>SPIO1W</b>
	108	<b>SPIO2W</b>
	144	<b>SPIO3W</b>

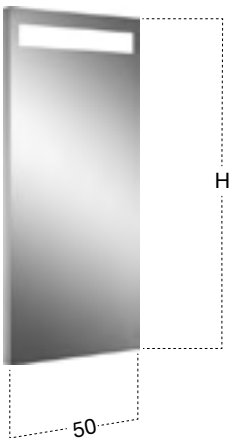

Specchio a filo lucido con illuminazione a led luce bianca completo di telaio in acciaio lucido AISI 304.

*Polished edge mirror with white led lighting complete with polished stainless steel frame AISI 304.*





H	L	art.
50	da 90 cm a 216 cm from 90 cm to 216 cm	<b>OBLÒ50</b>

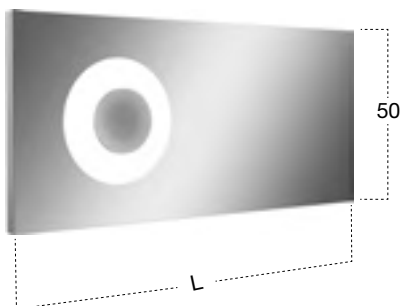

Versione sx - Left version

Specchio dx o sx a filo lucido con illuminazione a neon, specchio ingranditore 2x  $\varnothing$  155 mm completo di telaio in acciaio lucido AISI 304.

*Polished edge mirror with right or left neon lighting and magnifying mirror 2x  $\varnothing$  155 mm complete with polished stainless steel frame AISI 304.*



# OBLÒ



H	L	art.
50	da 90 cm a 216 cm from 90 cm to 216 cm	<b>OBLÒ150</b>

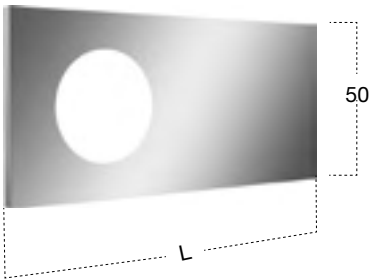

Versione sx - Left version

Specchio dx o sx a filo lucido con illuminazione a neon completo di telaio in acciaio lucido AISI 304.

*Polished edge mirror with right or left neon lighting and polished stainless steel frame AISI 304.*

# OBLÒ



L	H	art.
50	108	<b>OBLÒ2</b>
	144	<b>OBLÒ3</b>

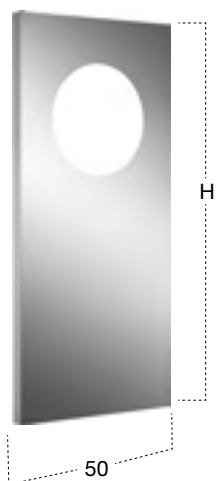

Specchio a filo lucido con illuminazione a neon completo di telaio in acciaio lucido AISI 304.

*Polished edge mirror with neon lighting and polished stainless steel frame AISI 304.*

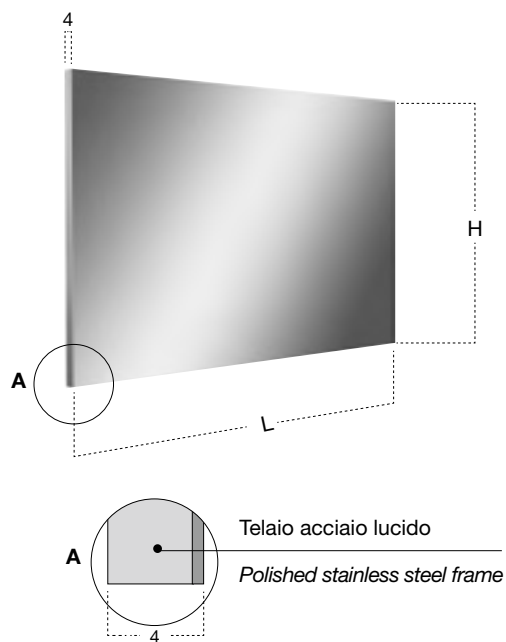

H	L	art.
50	da 54 cm a 216 cm <i>from 54 cm to 216 cm</i>	<b>SKERMO50</b>
75	da 54 cm a 216 cm <i>from 54 cm to 216 cm</i>	<b>SKERMO75</b>
90	da 54 cm a 216 cm <i>from 54 cm to 216 cm</i>	<b>SKERMO90</b>
100	da 54 cm a 216 cm <i>from 54 cm to 216 cm</i>	<b>SKERMO100</b>

Specchio a filo lucido completo di telaio in acciaio lucido AISI 304.  
*Polished edge mirror with polished stainless steel frame AISI 304.*



**SLOW** design AL Studio



L	H	art.
36	90	<b>SLOW1</b>
	108	<b>SLOW2</b>

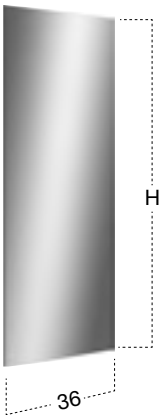

Specchio a filo lucido.  
Polished edge mirror.

**ALTEREGO** design AL Studio



L	H	art.
25	110	<b>ALTEREGO</b>

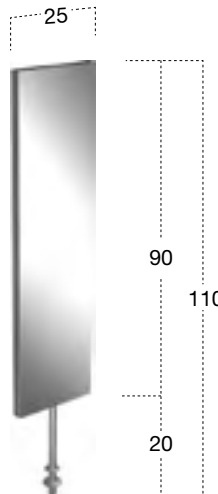

Specchio girevole bifacciale con struttura in acciaio inox satinato AISI 304.  
Double faced revolving mirror with satin stainless steel structure AISI 304.

specchiere e illuminazione  
mirrors and lighting







specchiere e illuminazione  
*mirrors and lighting*





**N.B.** Da L 72 a L 108 cm è possibile inserire 1 lampada, da L 117 a L 216 cm è possibile inserire 2 lampade a led.

**P.S.** From L 72 to L 108 cm is possible to use 1 light, from L 117 to L 216 cm it's possible to use 2 led lights.

# SEGRETO



H 50  
L da 72 cm a 216 cm  
from 72 cm to 216 cm

art.  
**SEGRETO**

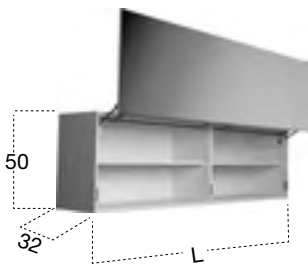

specchio  
mirror

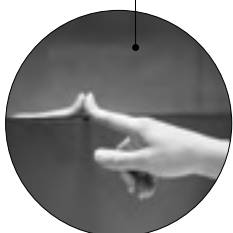

Pensile con anta a specchio ad apertura verticale, mediante sistema elettrico con possibile inserimento di illuminazione a led.

*Wall cabinet with vertical electrical flap-opening door. Upon request it can be produced with internal led lighting.*



**N.B.** É possibile inserire 1 lampada a led superiore e 1 lampada a led inferiore.

**P.S.** It is possible to insert 1 led light above and 1 led light below.





art. PRESA



N. 2 prese di corrente per pensili.

N. 2 electrical sockets for wall cabinets.

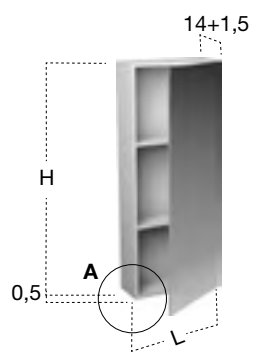

Versione dx - Right version

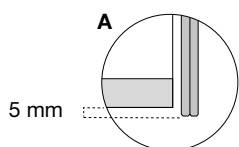

H	L	art.
50	36/45/54	<b>MANTRA150</b>
75	36/45/54	<b>MANTRA175</b>
90	36/45/54	<b>MANTRA190</b>

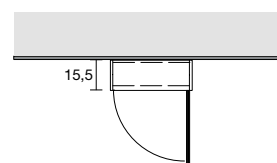
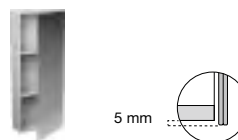

a Pensile a parete  
Wall cabinet

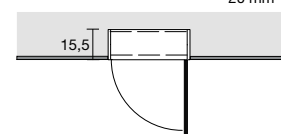
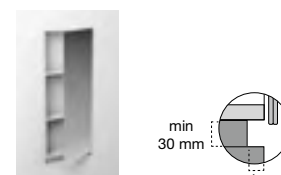

b Pensile incassato a parete  
Encased wall cabinet

Pensile dx o sx con 1 anta a specchio bifacciale e 1 ripiano interno per H 50 cm o 2 ripiani interni per H 75 o H 90 cm.

Right or left wall cabinet with 1 double face mirrored door and 1 internal shelf for H 50 cm or with 2 internal shelves for H 75 or H 90 cm.

specchiere e illuminazione  
mirrors and lighting





# MANTRA



specchiere e illuminazione  
*mirrors and lighting*





# MANTRA

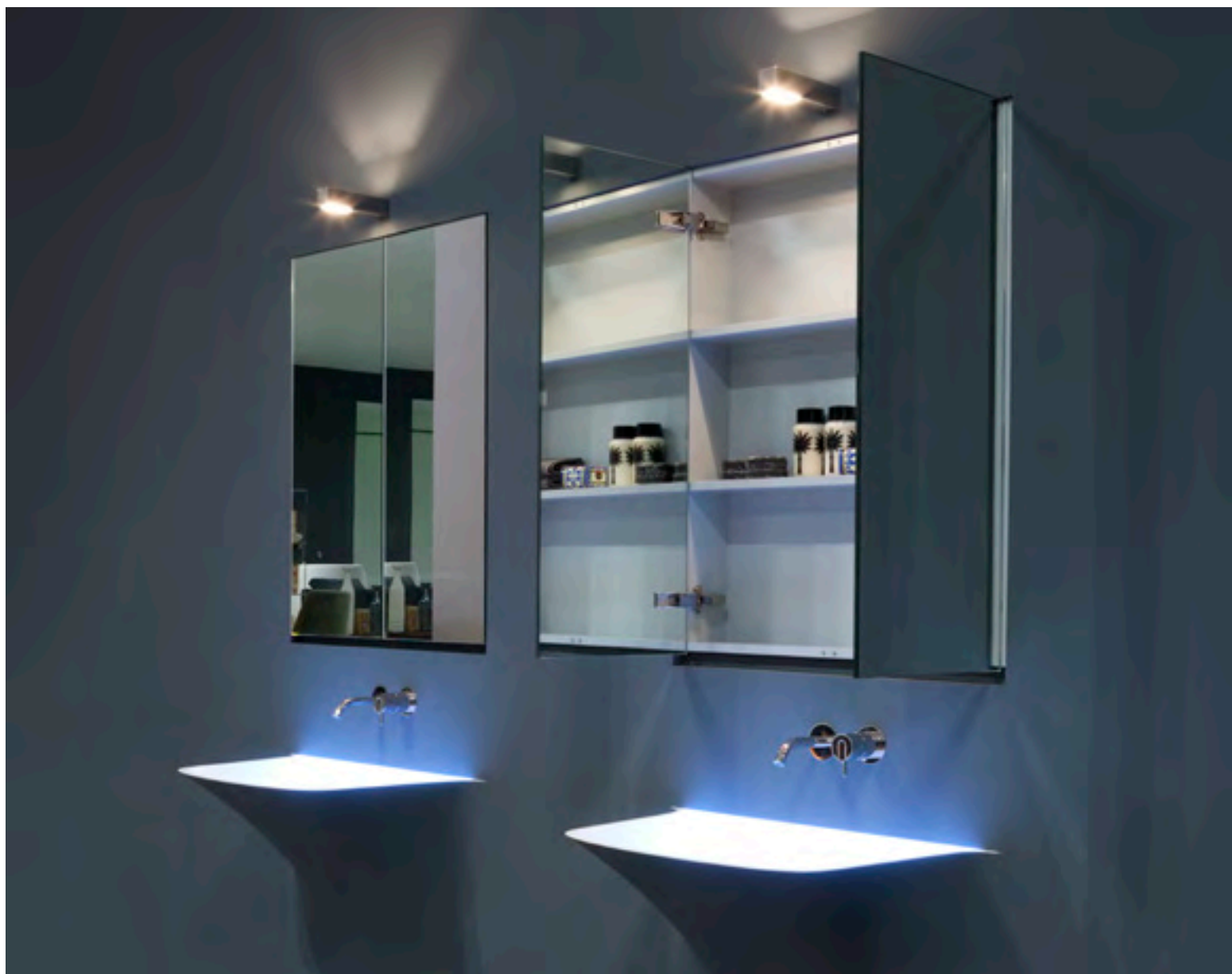

art. PRESA



N. 2 prese di corrente per pensili.

N. 2 electrical sockets for wall cabinets.

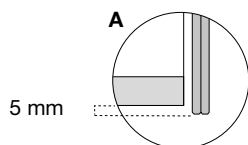
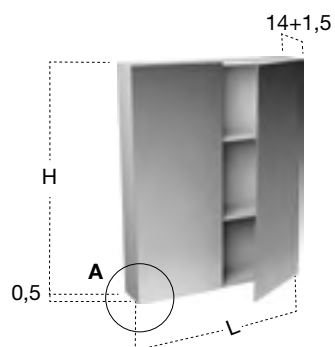

H	L	art.
50	72/90/108	<b>MANTRA250</b>
75	72/90/108	<b>MANTRA275</b>
90	72/90/108	<b>MANTRA290</b>

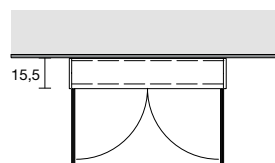
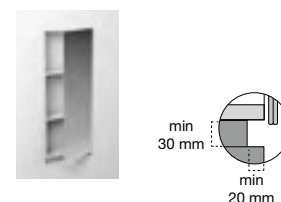
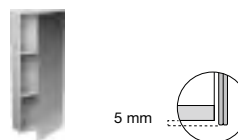

a Pensile a parete  
Wall cabinet

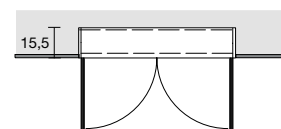

b Pensile incassato a parete  
Encased wall cabinet

Pensile con 2 ante a specchio bifacciali e 1 ripiano interno per H 50 cm o 2 ripiani interni per H 75 o H 90 cm.

Wall cabinet with 2 double face mirrored door and 1 internal shelf for H 50 cm or with 2 internal shelves for H 75 or H 90 cm.







specchiere e illuminazione  
*mirrors and lighting*







# TEATRO

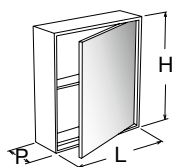

H	L	P	art.
50	27/36/45/54	14	<b>TEATRO15014</b>
		22	<b>TEATRO15022</b>
75	27/36/45/54	14	<b>TEATRO17514</b>
		22	<b>TEATRO17522</b>
100	27/36/45/54	14	<b>TEATRO10014</b>
		22	<b>TEATRO10022</b>
125	27/36/45/54	14	<b>TEATRO12514</b>
		22	<b>TEATRO12522</b>

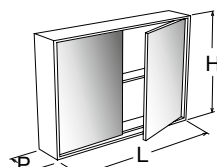

H	L	P	art.
50	54/72/90/108	14	<b>TEATRO25014</b>
		22	<b>TEATRO25022</b>
75	54/72/90/108	14	<b>TEATRO27514</b>
		22	<b>TEATRO27522</b>

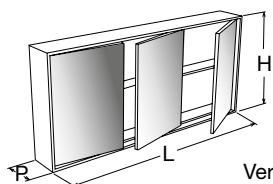

Versione sx - Left version

H	L	P	art.
50	81/108/135/162	14	<b>TEATRO35014</b>
		22	<b>TEATRO35022</b>
75	81/108/135/162	14	<b>TEATRO37514</b>
		22	<b>TEATRO37522</b>

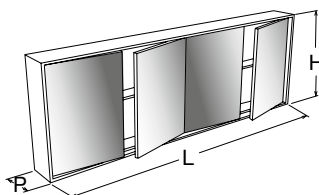

H	L	P	art.
50	108/144/180/216	14	<b>TEATRO45014</b>
		22	<b>TEATRO45022</b>
75	108/144/180/216	14	<b>TEATRO47514</b>
		22	<b>TEATRO47522</b>

# TEATRO



1 Prof. 14 cm / 14 cm D.

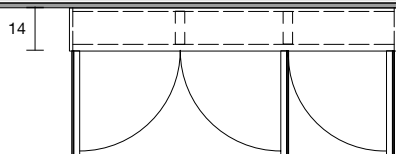

1a Pensile a parete  
*Wall cabinet*

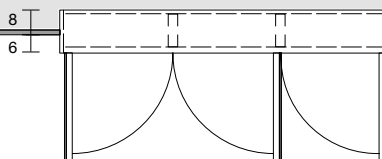

1b Pensile semincassato a parete  
*Semi-encased wall cabinet*

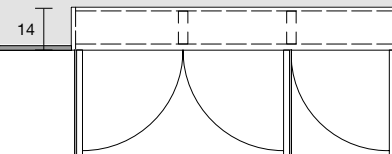

1c Pensile incassato a parete  
*Encased wall cabinet*

2 Prof. 22 cm / 22 cm D.

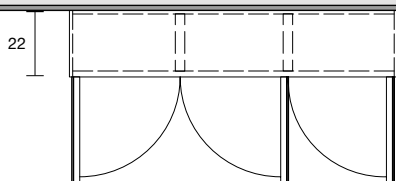

2a Pensile a parete  
*Wall cabinet*

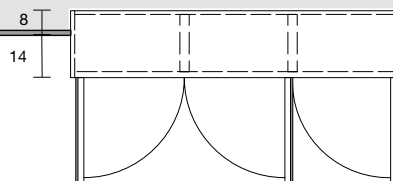

2b Pensile semincassato a parete  
*Semi-encased wall cabinet*

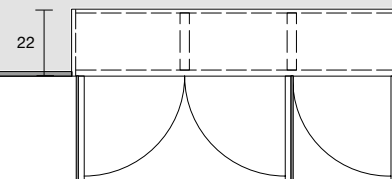

2c Pensile incassato a parete  
*Encased wall cabinet*

Pensile con anta a specchio e ripiani interni.  
*Mirrored front wall cabinet with internal shelf.*







H 42 L da 64 cm a 208 cm  
 art. PERIPLO  
 from 64 cm to 208 cm

CORNICE (La realizzazione della cornice è a cura del cliente)  
 FRAME (frame not included)

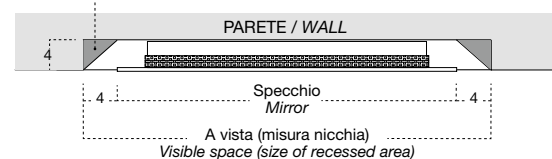

Specchio a filo lucido con illuminazione a led bianco, orizzontale o verticale da incasso a parete.

*Encased wall mount polished edge mirror with white led lighting, mounted horizontally or vertically.*

specchiere e illuminazione  
mirrors and lighting





H	L	P	art.
220	da 27 cm a 90 cm	11,6	<b>DIVO220 / DIVO220W / DIVO220L</b>
	<i>from 27 cm to 90 cm</i>		

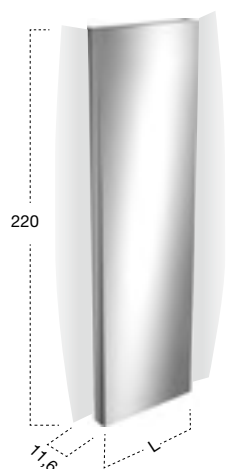

Specchio a filo lucido senza illuminazione o con possibilità di illuminazione a led bianco o bianco e blu, completo di telaio laccato nero goffrato.

*Polished edge mirror without lighting or with white led lighting or white/blue led lighting, lacquered frame embossed black.*

specchiere e illuminazione  
mirrors and lighting







H	L
220	180

art.  
**DAMONE**

specchiere e illuminazione  
mirrors and lighting

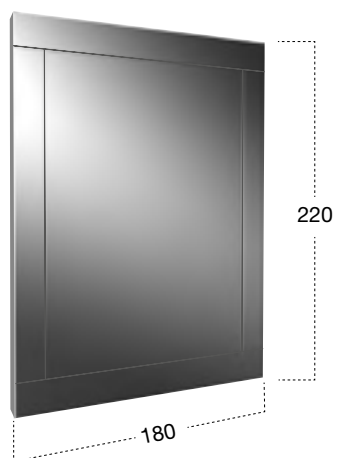

Specchio a filo lucido con cornice a disegno completo di telaio laccato nero gofrato.

*Polished edge mirror complete with lacquered frame embossed black.*









H	L	P	art.
50	da 54 cm a 216 cm <i>from 54 cm to 216 cm</i>	6	<b>SFOGLIA50</b>
75	da 54 cm a 216 cm <i>from 54 cm to 216 cm</i>	6	<b>SFOGLIA75</b>
90	da 54 cm a 216 cm <i>from 54 cm to 216 cm</i>	6	<b>SFOGLIA90</b>
108	da 54 cm a 216 cm <i>from 54 cm to 216 cm</i>	6	<b>SFOGLIA108</b>

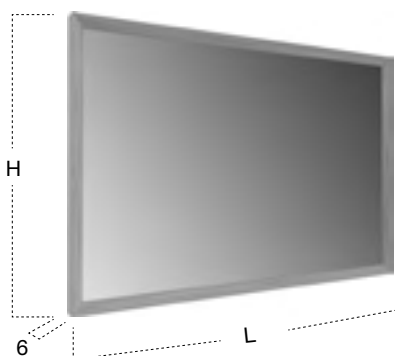

Specchio a filo lucido orizzontale e verticale, con cornice in legno o laccata.

*Polished edge mirror mounted horizontally or vertically with a wood or lacquered frame.*





H	L	P	art.
75	da 72 cm a 216 cm <i>from 72 cm to 216 cm</i>	6	<b>SFOGLIA75L</b>

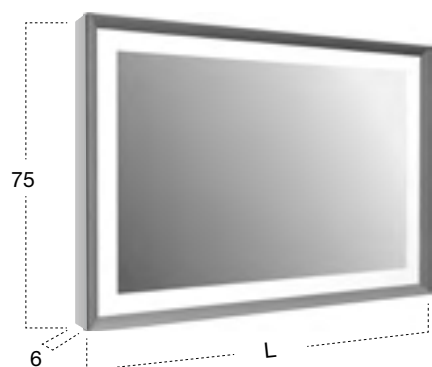

Specchio a filo lucido orizzontale e verticale, con cornice in legno o laccata e illuminazione a led bianco.

*Polished edge mirror mounted horizontally or vertically with a lacquered or wood frame and white led lighting.*

specchiere e illuminazione  
*mirrors and lighting*





**SOTTOQUADRO e QUADRO** design Enrico Imperi

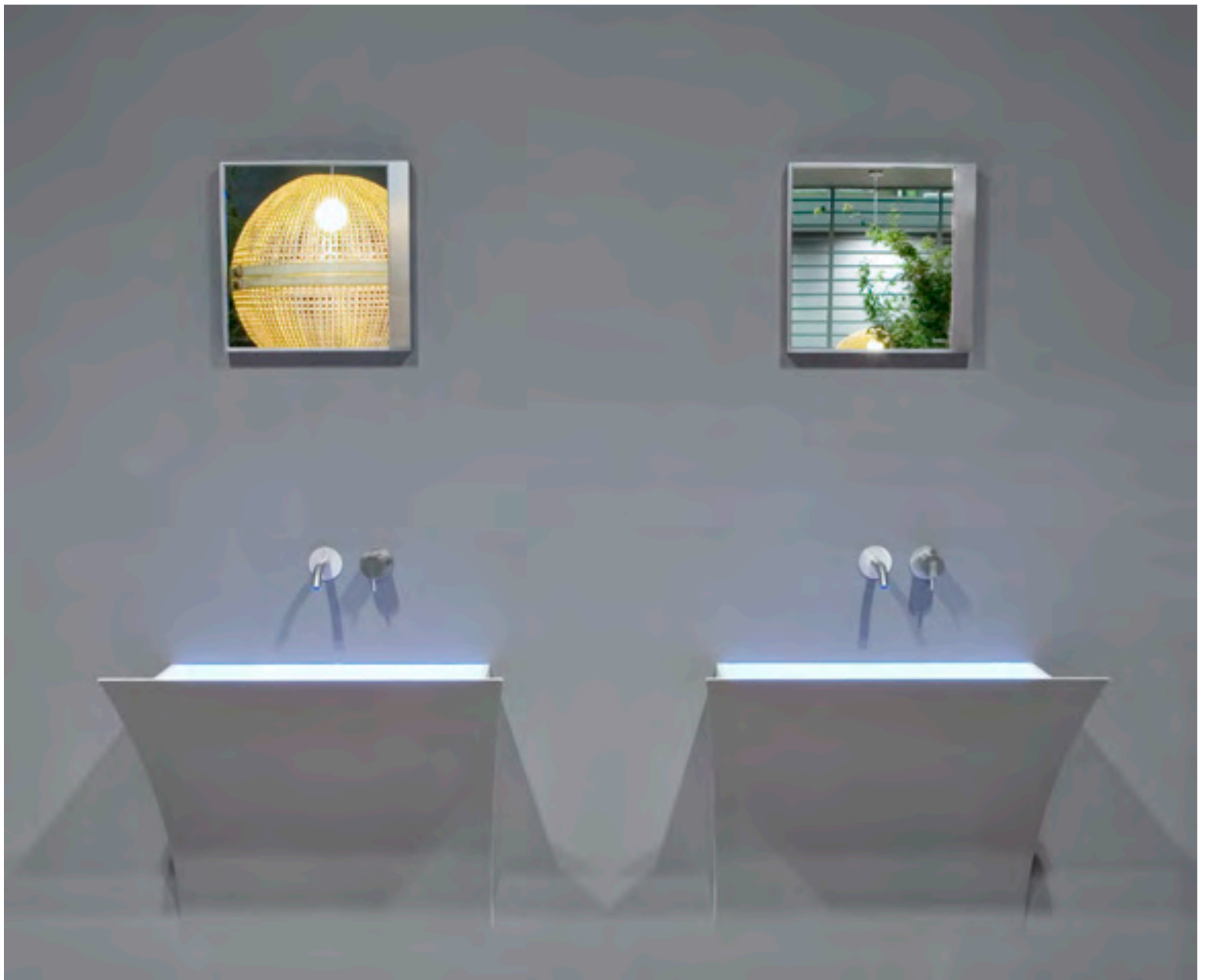

H	L	art.
108	45	<b>SOTTOQUADRO</b>

H	L	art.
36	36	<b>QUADRO</b>

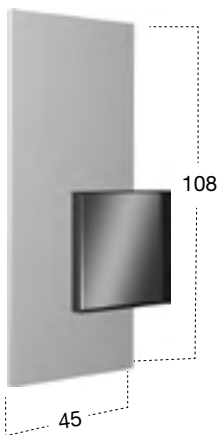

Versione dx - Right version

Specchio dx o sx a filo lucido con cornice in acciaio inox satinato AISI 304 completo di pannello in legno o laccato con illuminazione a led bianco.

*Right or left polished edge mirror with satin stainless steel frame AISI 304 complete with lacquered or wooden panel and white led lighting.*

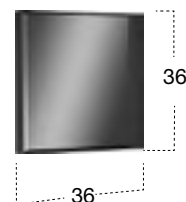

Versione dx - Right version

Specchio dx o sx a filo lucido con cornice in acciaio inox satinato AISI 304.

*Right or left polished edge mirror with satin stainless steel frame AISI 304.*









specchiere e illuminazione  
mirrors and lighting

# LUXOR

Cristallo argentato rosé / *Rosé silvered glass*



Cristallo argentato blu / *Blu silvered glass*



specchiere e illuminazione  
*mirrors and lighting*



# LUXOR

Cristallo argentato bronzo / *Bronzo silvered glass*



Cristallo argentato bronzo / *Bronzo silvered glass*



specchiere e illuminazione  
*mirrors and lighting*



# LUXOR

Cristallo argentato fumé / *Fumè silvered glass*





Cristallo argentato acquamarina / *Acquamarina silvered glass*



specchiere e illuminazione  
*mirrors and lighting*

# LUXOR

Cristallo argentato bronzo / *Bronzo silvered glass*





Cristallo argentato rosé / Rosé silvered glass





# LUXOR

Specchio tondo molato.

*Beveled round mirror.*

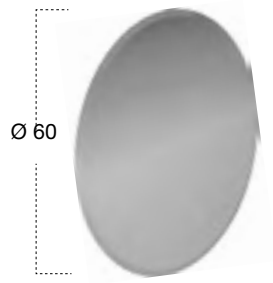

Ø 60

Ø	art.
60	<b>LUXOR1</b>

Specchio quadrato molato.

*Beveled square mirror.*

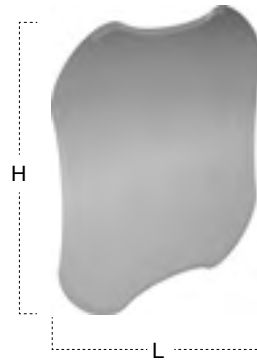

H

L

H	L	art.
75	75	<b>LUXOR475</b>
90	90	<b>LUXOR490</b>

Specchio ovale orizzontale o verticale molato.

*Horizontal or vertical beveled oval mirror.*

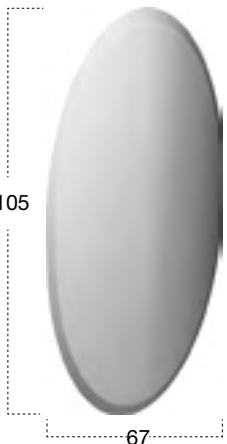

105

67

orizzontale o verticale  
*horizontal and vertical*

H	L	art.
105	67	<b>LUXOR2</b>

Specchio rettangolare orizzontale o verticale molato.

*Horizontal or vertical beveled rectangular mirror.*

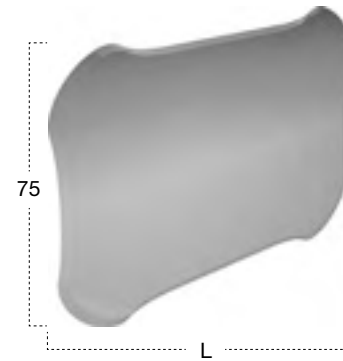

75

L

H	L	art.
75	117	<b>LUXOR5117</b>
75	126	<b>LUXOR5126</b>

Specchio tondo molato.

*Beveled round mirror.*

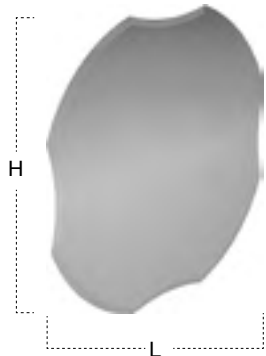

H

L

H	L	art.
75	75	<b>LUXOR375</b>
90	90	<b>LUXOR390</b>

Specchio ovale orizzontale o verticale molato.

*Horizontal or vertical beveled oval mirror.*

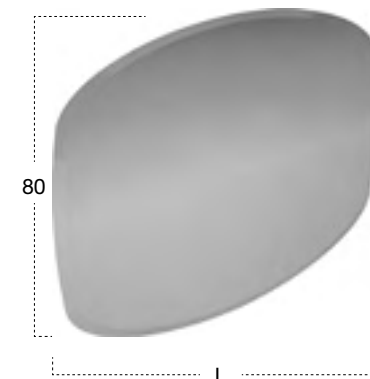

80

L

H	L	art.
80	117	<b>LUXOR6117</b>
80	126	<b>LUXOR6126</b>

# LUXOR

Specchio tondo molato con cornice in cristallo colorato argentato disponibile nei diversi colori: fumé, bronzo, rosé, blu, acquamarina.

*Round beveled mirror with a coloured and silvered glass frame available in the various colours: fumé, bronzo, rosé, blu and acquamarina.*

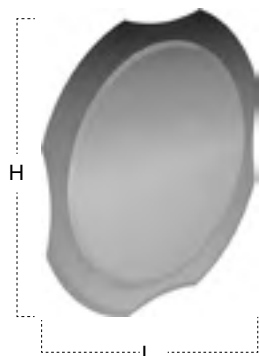

H	L	art.
75	75	<b>LUXOR775</b>
90	90	<b>LUXOR790</b>

Specchio rettangolare orizzontale o verticale molato con cornice in cristallo colorato argentato disponibile nei diversi colori: fumé, bronzo, rosé, blu, acquamarina.

*Rectangular beveled mirror horizontal or vertical, with a coloured and silvered glass frame available in the various colours: fumé, bronzo, rosé, blu and acquamarina.*

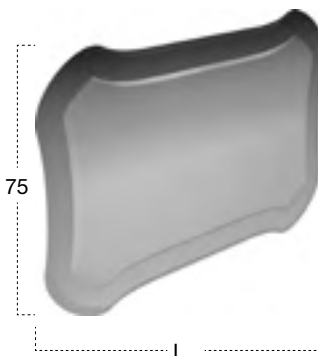

H	L	art.
75	117	<b>LUXOR9117</b>
75	126	<b>LUXOR9126</b>

Specchio quadrato con cornice in cristallo colorato argentato disponibile nei diversi colori: fumé, bronzo, rosé, blu e acquamarina.

*Round beveled mirror with a coloured and silvered glass frame available in the various colours: fumé, bronzo, rosé, blu and acquamarina.*



H	L	art.
75	75	<b>LUXOR875</b>
90	90	<b>LUXOR890</b>

Specchio ovale orizzontale o verticale, molato con cornice in cristallo colorato argentato disponibile nei diversi colori: fumé, bronzo, rosé, blu e acquamarina.

*Oval beveled mirror horizontal or vertical, with a coloured and silvered glass frame available in the various colours: fumé, bronzo, rosé, blu and acquamarina.*

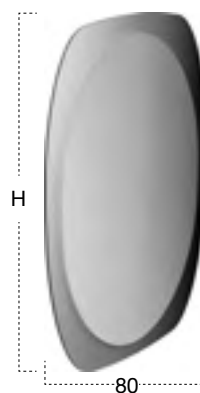

H	L	art.
80	117	<b>LUXOR10117</b>
80	126	<b>LUXOR10126</b>







art. **FORMA85**

art. **FORMA54**

art. **FORMA154**

Ø  
85

art.  
**FORMA85**

H	L
85	54
185	54

art.  
**FORMA54**  
**FORMA154**

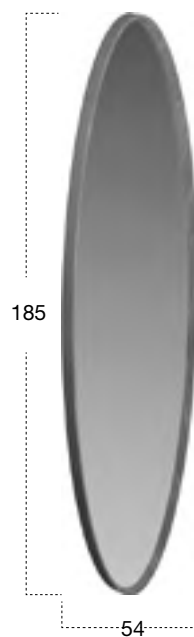
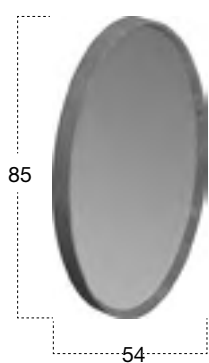
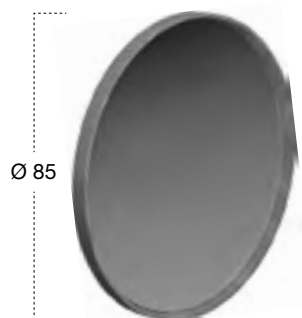

Specchio molato con cornice in massello di legno.  
*Round beveled mirror with solid wood frame.*

specchiere e illuminazione  
mirrors and lighting







H	P	L	art.
30	11	6,5	<b>RONDÓ</b>

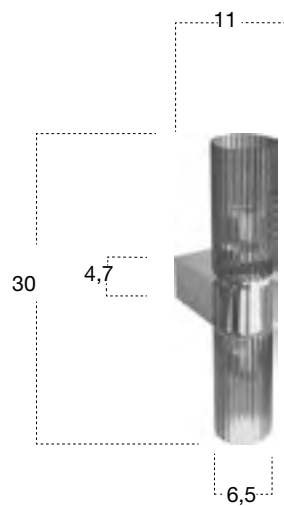

Lampada alogena a parete in vetro soffiato con supporti in ottone cromo lucido completa di 2 lampade.

*Halogen wall lamp with blown glass and polished brass supports complete with 2 bulbs.*





## RIGA design Massimo Broglio

Nel nome vi è già la dichiarazione di intenti del progetto. Una riga è un segno, un tratto che si allunga e si accorcia secondo volontà. La lampada è questo. Un oggetto minimalista con dimensioni in lunghezza che possono essere personalizzate secondo le necessità del cliente.

Riga è una lampada molto semplice, realizzata sostanzialmente da quattro parti: un estruso di alluminio della lunghezza richiesta, due frontali di chiusura e un diffusore in policarbonato.

Le applicazioni sono molteplici. L'elemento può essere posizionato a parete e dimensionato a misura, in relazione alle dimensioni dello specchio, oppure applicato a soffitto sospeso su cavetti di acciaio. In futuro sarà presentata anche una versione da terra free-standing. Il tutto ovviamente con tecnologia a strip-led.

La lampada viene realizzata in alluminio anodizzato o brunito anodizzato con diffusore in policarbonato opalino bianco.

*The name already declares the intention of the project. A line is a sign, expanding and contracting according to will. This is the lamp. A minimalist object with dimensions in length that can be customized depending on the client's needs.*

*Riga is a very simple lamp, made substantially of four parts: an aluminum extrusion of any required length, two closing parts and a diffuser in polycarbonate.*

*Numerous the applications. The item can be installed on the wall and made to measure, made to measure according to the length of the mirror or even hung from the ceiling with steel wires. In the future a freestanding model will be introduced. Obviously all models with a strip of led.*

*The lamp is made of anodized aluminum or burnished anodized aluminum with a white opal polycarbonate diffuser.*

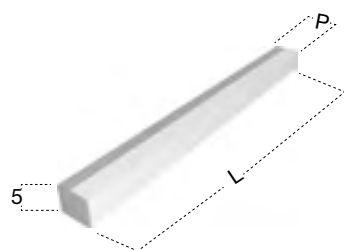

L	P	H	art.		L	P	H	art.	
54	6	5	<b>RIGA54</b>	20,52 W	54	7,5	5	<b>RIGA154</b>	20,52 W
63	6	5	<b>RIGA63</b>	23,94 W	63	7,5	5	<b>RIGA163</b>	23,94 W
72	6	5	<b>RIGA72</b>	27,36 W	72	7,5	5	<b>RIGA172</b>	27,36 W
81	6	5	<b>RIGA81</b>	30,78 W	81	7,5	5	<b>RIGA181</b>	30,78 W
90	6	5	<b>RIGA90</b>	34,20 W	90	7,5	5	<b>RIGA190</b>	34,20 W
99	6	5	<b>RIGA99</b>	37,62 W	99	7,5	5	<b>RIGA199</b>	37,62 W
108	6	5	<b>RIGA108</b>	41,04 W	108	7,5	5	<b>RIGA1108</b>	41,04 W
117	6	5	<b>RIGA117</b>	44,46 W	117	7,5	5	<b>RIGA1117</b>	44,46 W
126	6	5	<b>RIGA126</b>	47,88 W	126	7,5	5	<b>RIGA1126</b>	47,88 W
135	6	5	<b>RIGA135</b>	51,30 W	135	7,5	5	<b>RIGA1135</b>	51,30 W
144	6	5	<b>RIGA144</b>	54,72 W	144	7,5	5	<b>RIGA1144</b>	54,72 W
153	6	5	<b>RIGA153</b>	58,14 W	153	7,5	5	<b>RIGA1153</b>	58,14 W
162	6	5	<b>RIGA162</b>	61,56 W	162	7,5	5	<b>RIGA1162</b>	61,56 W
171	6	5	<b>RIGA171</b>	64,98 W	171	7,5	5	<b>RIGA1171</b>	64,98 W
180	6	5	<b>RIGA180</b>	68,40 W	180	7,5	5	<b>RIGA1180</b>	68,40 W
189	6	5	<b>RIGA189</b>	71,82 W	189	7,5	5	<b>RIGA1189</b>	71,82 W
198	6	5	<b>RIGA198</b>	75,24 W	198	7,5	5	<b>RIGA1198</b>	75,24 W
207	6	5	<b>RIGA207</b>	78,66 W	207	7,5	5	<b>RIGA1207</b>	78,66 W
216	6	5	<b>RIGA216</b>	82,08 W	216	7,5	5	<b>RIGA1216</b>	82,08 W

Lampada da parete o da soffitto a led in alluminio anodizzato o brunito anodizzato con diffusore in policarbonato opalino bianco e alimentatore remoto.

*Wall or ceiling led lamp made of anodized aluminum or burnished anodized aluminum with a white opal polycarbonate diffuser and remote power supply.*

Alta resa cromatica CRI80 3000K 24V  
High chromatic yield CRI80 3000K 24V

Lampada da parete o da soffitto a led in alluminio anodizzato o brunito anodizzato con diffusore in policarbonato opalino bianco e alimentatore incorporato.

*Wall or ceiling led lamp made of anodized aluminum or burnished anodized aluminum with a white opal polycarbonate diffuser and incorporated power supply.*

RIGA







specchiere e illuminazione  
*mirrors and lighting*

RIGA





specchiere e illuminazione  
mirrors and lighting





# RIGA

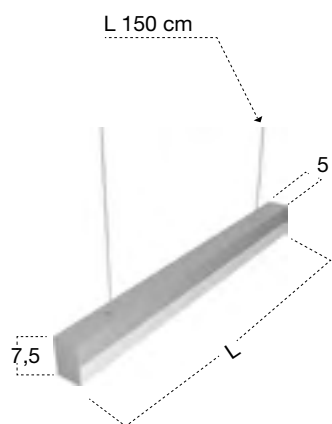

L	P	H	art.	
54	5	7,5	<b>RIGA_S154</b>	20,52 W
63	5	7,5	<b>RIGA_S163</b>	23,94 W
72	5	7,5	<b>RIGA_S172</b>	27,36 W
81	5	7,5	<b>RIGA_S181</b>	30,78 W
90	5	7,5	<b>RIGA_S190</b>	34,20 W
99	5	7,5	<b>RIGA_S199</b>	37,62 W
108	5	7,5	<b>RIGA_S1108</b>	41,04 W
117	5	7,5	<b>RIGA_S1117</b>	44,46 W
126	5	7,5	<b>RIGA_S1126</b>	47,88 W
135	5	7,5	<b>RIGA_S1135</b>	51,30 W
144	5	7,5	<b>RIGA_S1144</b>	54,72 W
153	5	7,5	<b>RIGA_S1153</b>	58,14 W
162	5	7,5	<b>RIGA_S1162</b>	61,56 W
171	5	7,5	<b>RIGA_S1171</b>	64,98 W
180	5	7,5	<b>RIGA_S1180</b>	68,40 W
189	5	7,5	<b>RIGA_S1189</b>	71,82 W
198	5	7,5	<b>RIGA_S1198</b>	75,24 W
207	5	7,5	<b>RIGA_S1207</b>	78,66 W
216	5	7,5	<b>RIGA_S1216</b>	82,08 W

Alta resa cromatica CRI80 3000K 24V  
High chromatic yield CRI80 3000K 24V

Lampada da sospensione a led in alluminio anodizzato o brunito anodizzato con diffusore in policarbonato opalino bianco con kit sospensione e alimentatore incorporato.

*Hanging led lamp made of anodized aluminum or burnished anodized aluminum with a white opal polycarbonate diffuser, suspension kit and incorporated power supply.*







# RIGA

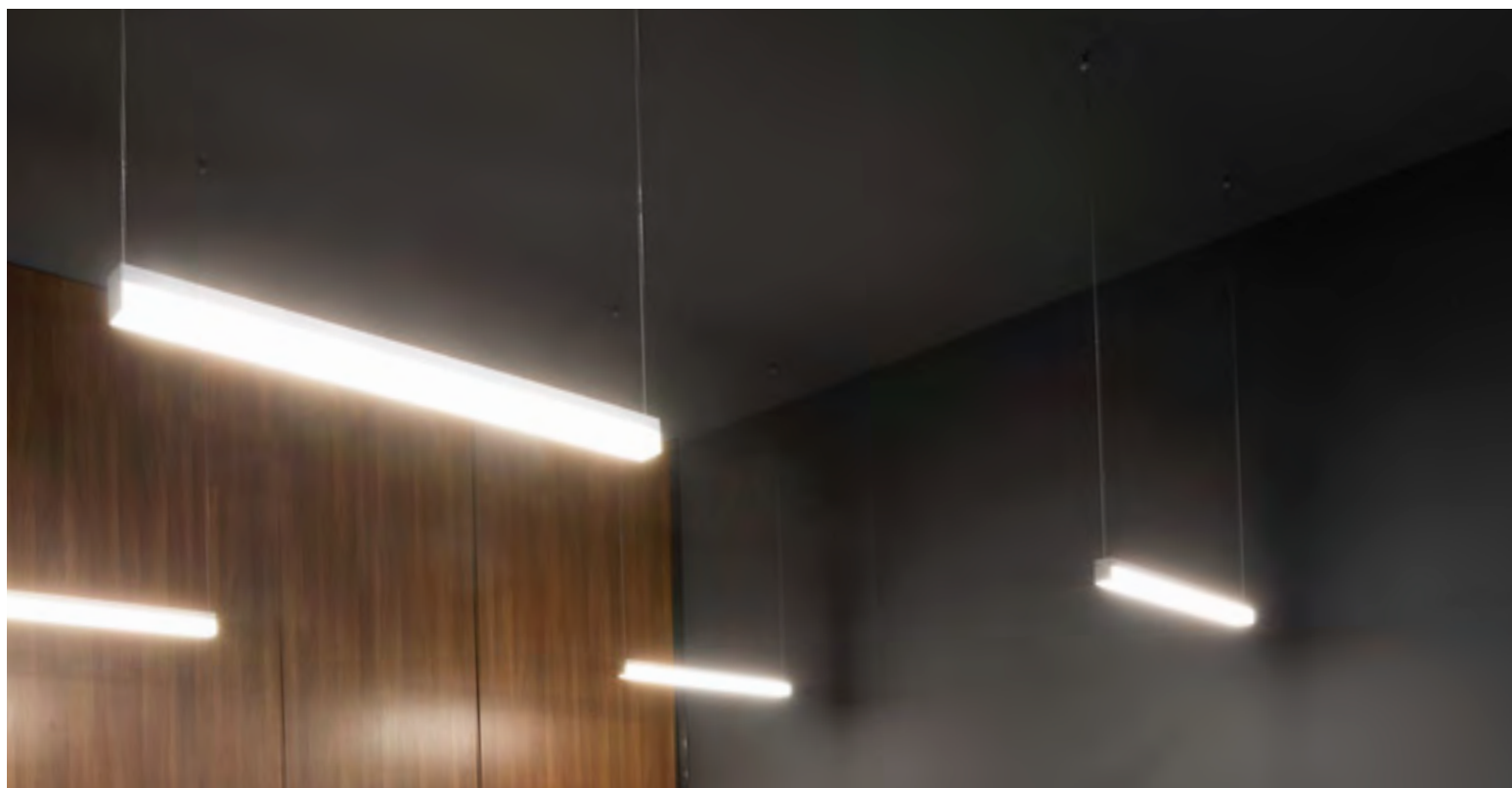

Sospesa  
*Hanging*



A soffitto  
*Ceiling mounted*



Orizzontale a parete  
*Horizontal on the wall*

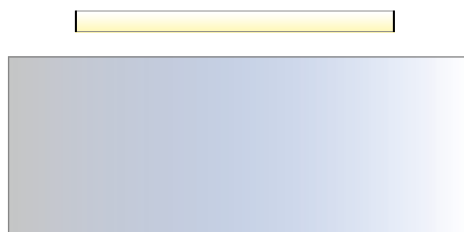

Orizzontale appoggiata  
*Horizontal supported*

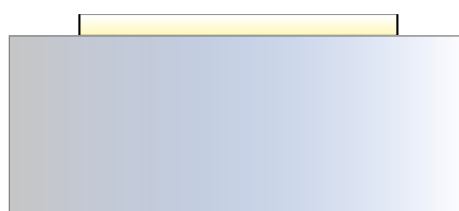

Verticale a parete  
*Vertical on the wall*



Verticale appoggiata  
*Vertical supported*

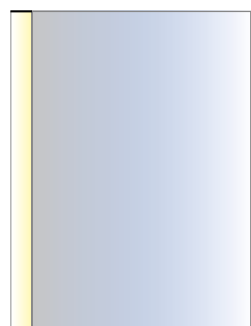

A parete o a soffitto come composizione  
*On the wall or ceiling as a composition*

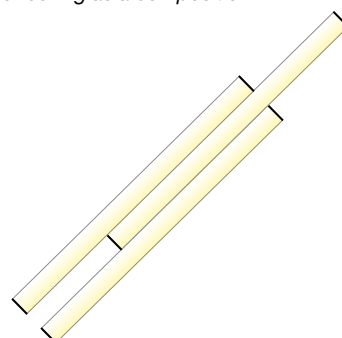



## CURVA

Curva nasce dal desiderio di offrire una lampada da specchio per l'ambiente bagno con specifiche caratteristiche di pulizia della linea e un elevato contenuto tecnologico di innovazione.

Curva è lampada da specchio a led senza necessità di un trasformatore in quanto il supporto di alluminio ha la doppia funzione di sostenere la lampadina a led e dissipare il calore che questa produce, per evitare il surriscaldamento della stessa.

La linea di Curva non è altro che un portalampadina e il suo design è conseguenza del funzionamento della lampadina stessa.

Curva up e Curva down

Curva può essere posizionata sia in alto che in basso. La versione **down** va applicata sugli specchi del catalogo di antoniolupi e pertanto la luce è tangente allo specchio; la versione **up** proietta la luce verso l'alto e quindi ha la funzione di essere una applique di servizio all'interno del bagno.

Curva può essere utilizzata anche in altri ambienti della casa.

*Curva is born from the desire to offer a mirror lamp for the bathroom with a specific clean line and high-tech innovation.*

*Curva is a led mirror lamp without need for a transformer since the aluminum support has a double function of sustaining the bulb and dissipating heat that it produces to avoid the overheating of the bulb itself.*

*Curva up and Curva down*

*Curva can be positioned up or down. The **down** version must be applied to the mirrors in the antoniolupi catalogue and therefore the light is tangent to the mirror while the **up** version projects light upward and functions as a sconce inside the bathroom. Curva can be used in other rooms of the house.*







# CURVA



H	P	L	art.
14	10	10	<b>CURVA_DOWN</b>

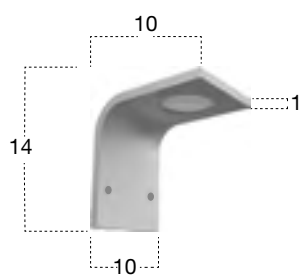

Lampada da parete a led con illuminazione diretta in alluminio verniciato bianco o anodizzato brunito completa di lampada.

*Wall led lamp with direct lighting in aluminum lacquered white or burnished anodized aluminum complete with bulb.*









specchiere e illuminazione  
*mirrors and lighting*



## CURVA

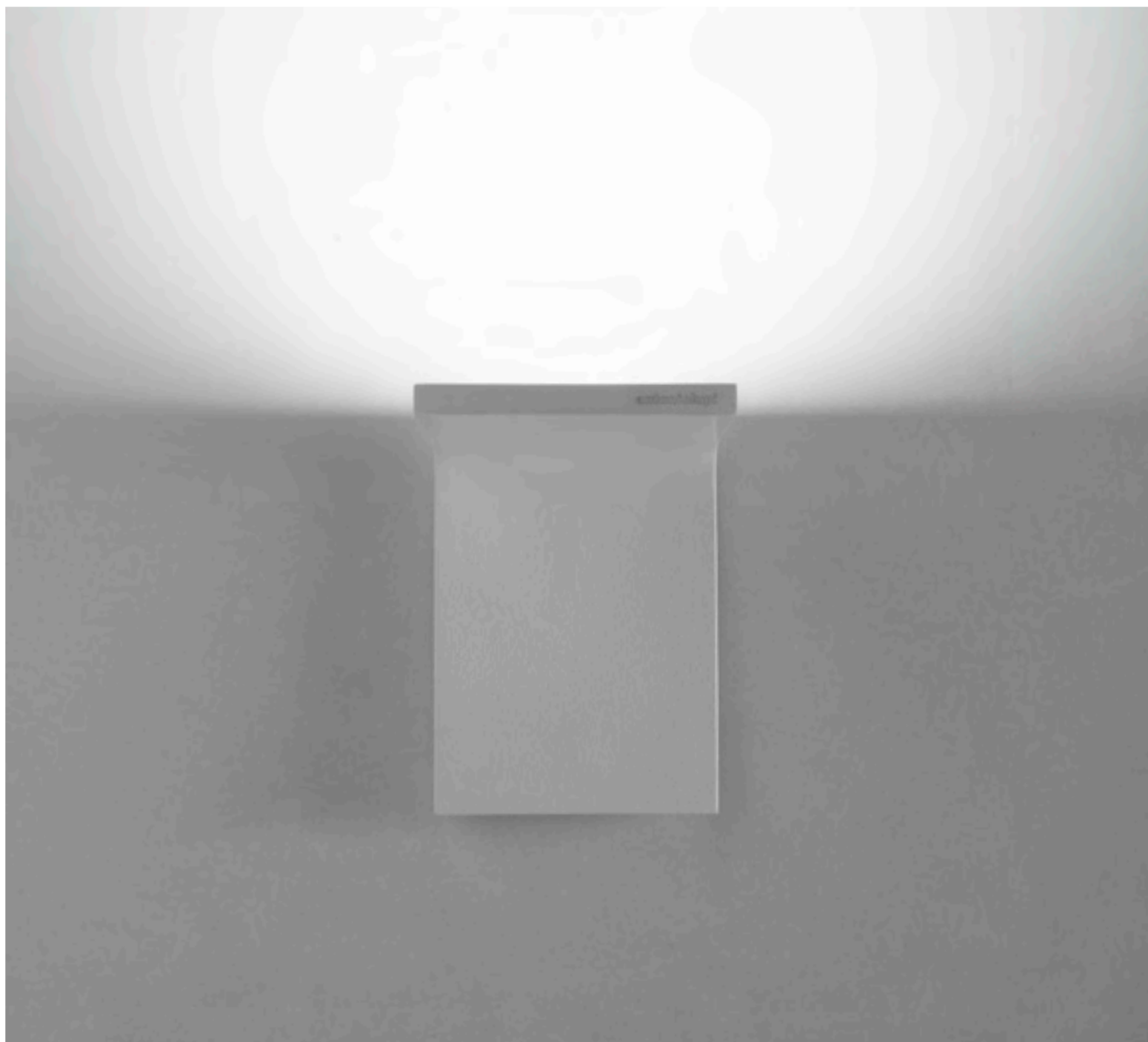

H	P	L	art.
14	10	10	<b>CURVA_UP</b>

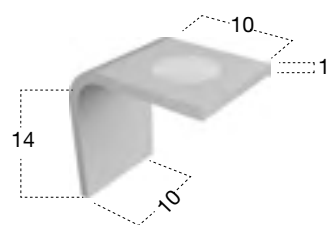

Lampada da parete a led con illuminazione indiretta in alluminio verniciato bianco o anodizzato brunito completa di lampada.

*Wall led lamp with indirect lighting in aluminum lacquered white or burnished anodized aluminum complete with bulb.*







specchiere e illuminazione  
mirrors and lighting

H	P	L	art.
4	16	4	<b>RAGGIO</b>

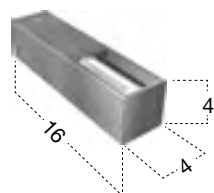

Lampada alogena a parete in acciaio inox AISI 304 satinato o lucido completa di lampada.

*Satin or polished stainless steel AISI 304 wall mounted halogen light complete with bulb.*



H	P	L	art.
10	10	19	<b>LIGHT1</b>

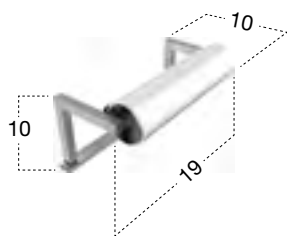

Lampada alogena in vetro sabbato con supporti in ottone cromo lucido completa di lampada.

*Sand blasted glass halogen light with polished chrome brass supports complete with bulb.*



# LIGHT



specchiere e illuminazione  
mirrors and lighting

H	P	L	art.
10	10	34	<b>LIGHT2</b>

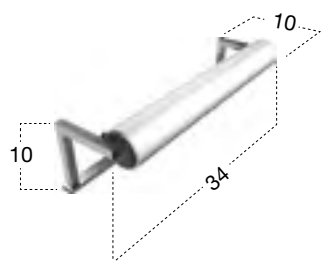

Lampada alogena in vetro sabbato con supporti in ottone cromo lucido completa di 2 lampade.

*Sand blasted glass halogen light with polished chrome brass supports complete with 2 bulbs.*





H	P	L	art.
6,6	11,6	19	<b>LIGHT3</b>

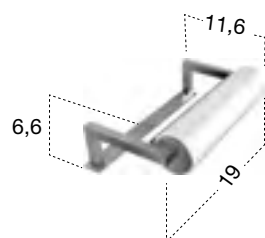

Lampada alogena in vetro sabbato con supporti in ottone cromo lucido completa di lampada, per pensili.

*Sand blasted glass halogen light with polished chrome brass supports complete with bulb for wall cabinets.*



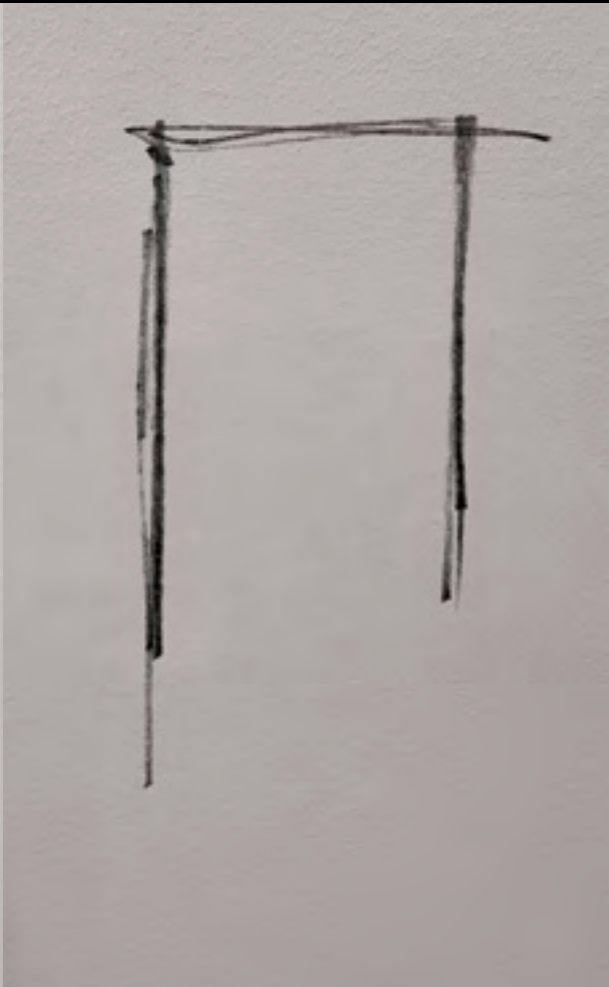
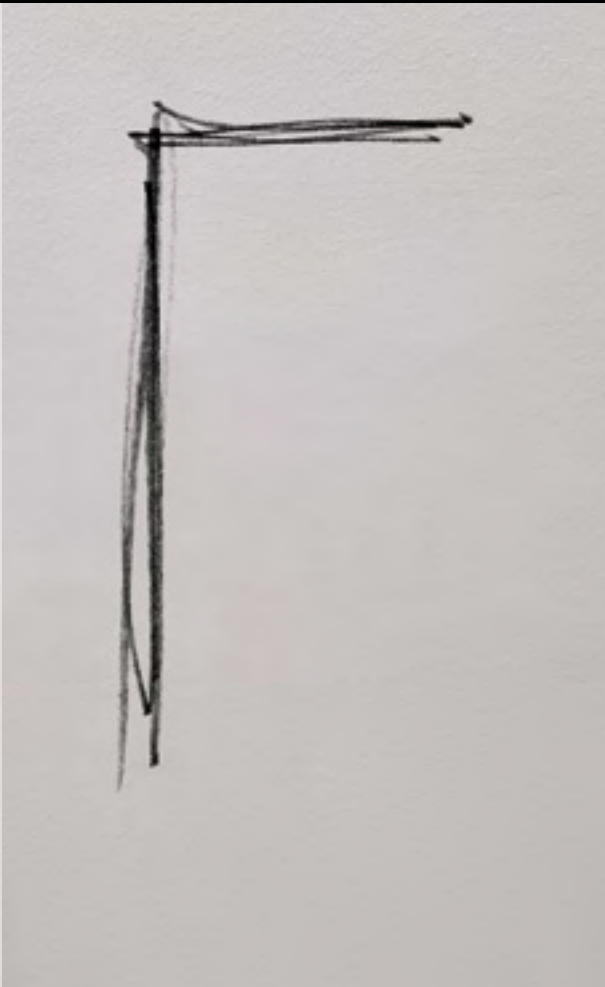

**ACCESSORI  
ACCESSORIES**

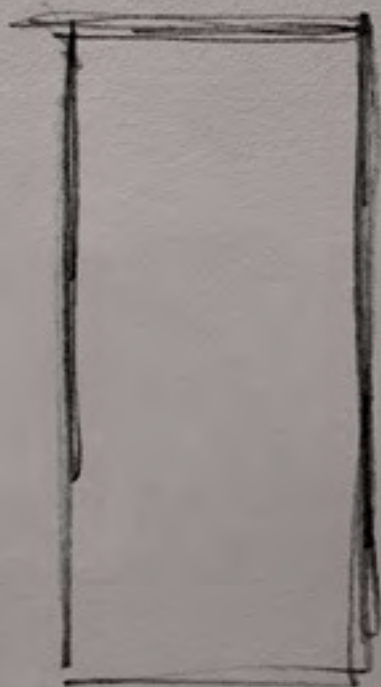



**SESAMO** design Arkimera

Modello e design registrato  
*Registered model and design*

**APRITI...**  
OPEN...





# DOVE SONO GLI ACCESSORI

WHERE ARE THE ACCESSORIES?



# ET VOILÀ, SEMPLICEMENTE GENIALE

ET VOILA, SIMPLY BRILLIANT









# SESAMO

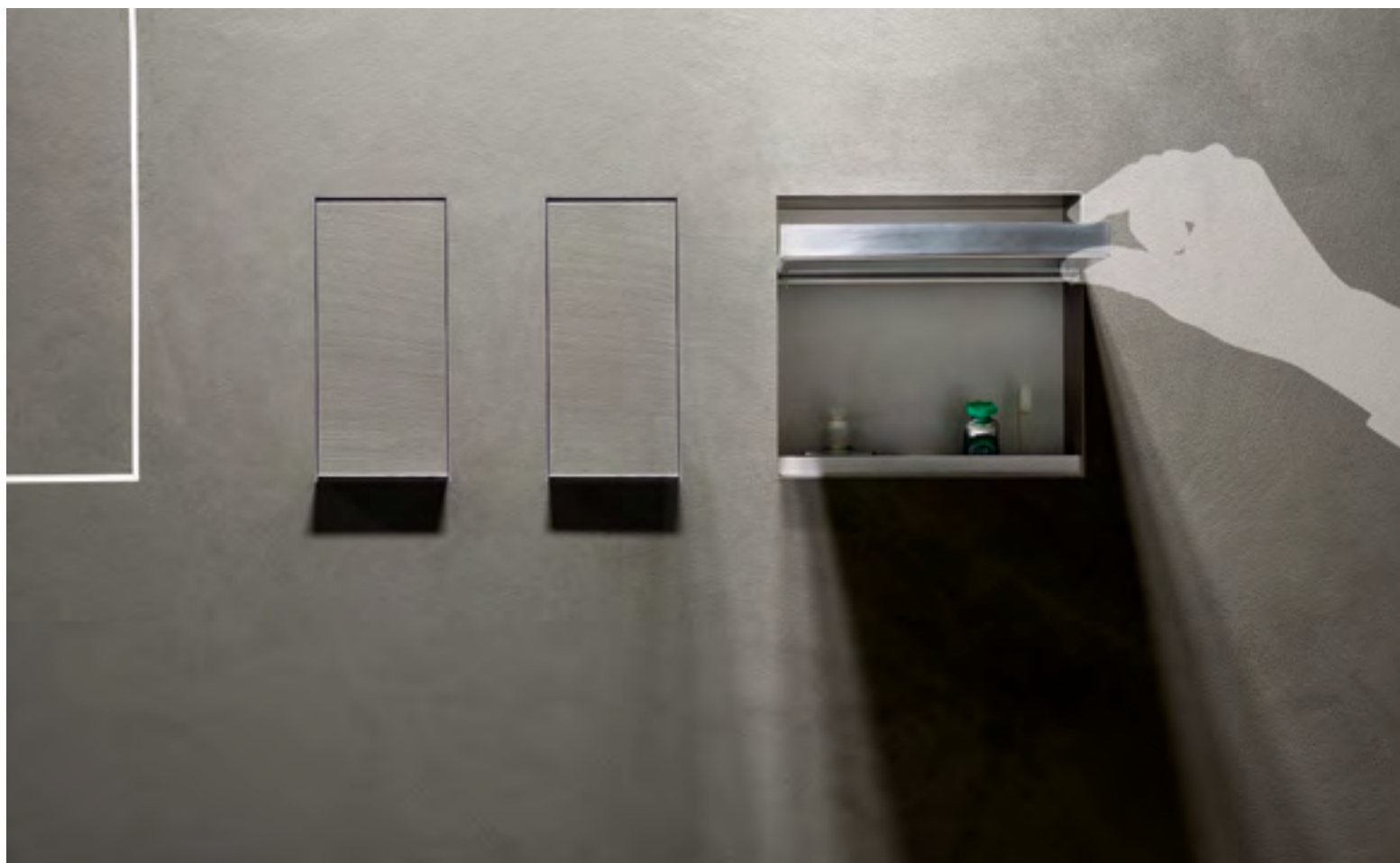
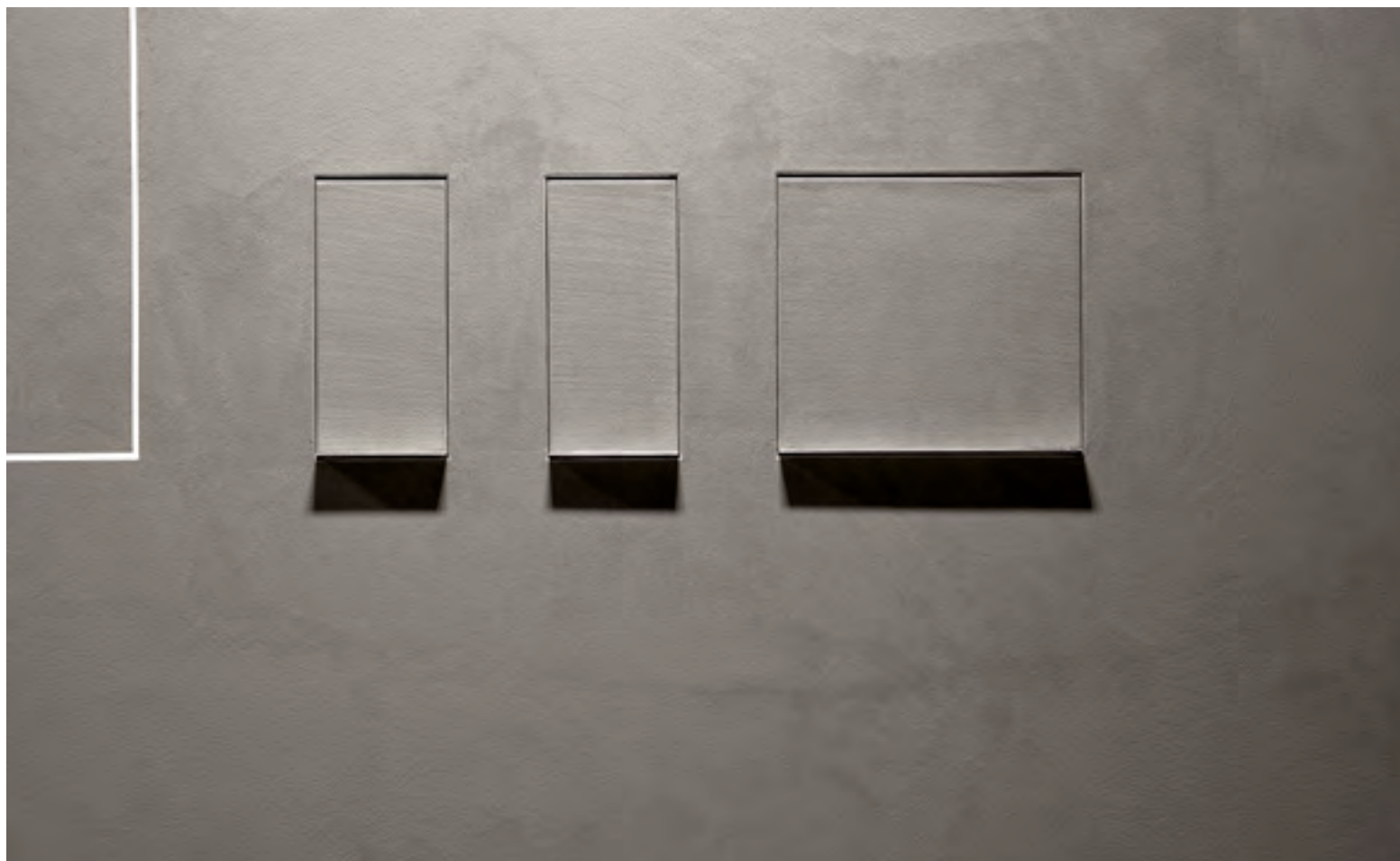

accessori  
accessoires





# SESAMO, COME FARSI NOTARE SENZA FARSI NOTARE

HOW TO STAND OUT WITHOUT STANDING OUT

Eleganza, pulizia formale, personalizzazione, un bagno che si distingue da tutti gli altri. Un'eleganza che viene dal togliere invece che dall'aggiungere, che proprio perché non si vede, si fa notare.

*Elegance, clean lines, personalization, a bathroom that stands out from all the others. An elegance that comes from less than more, because you can't see them, they are noted.*

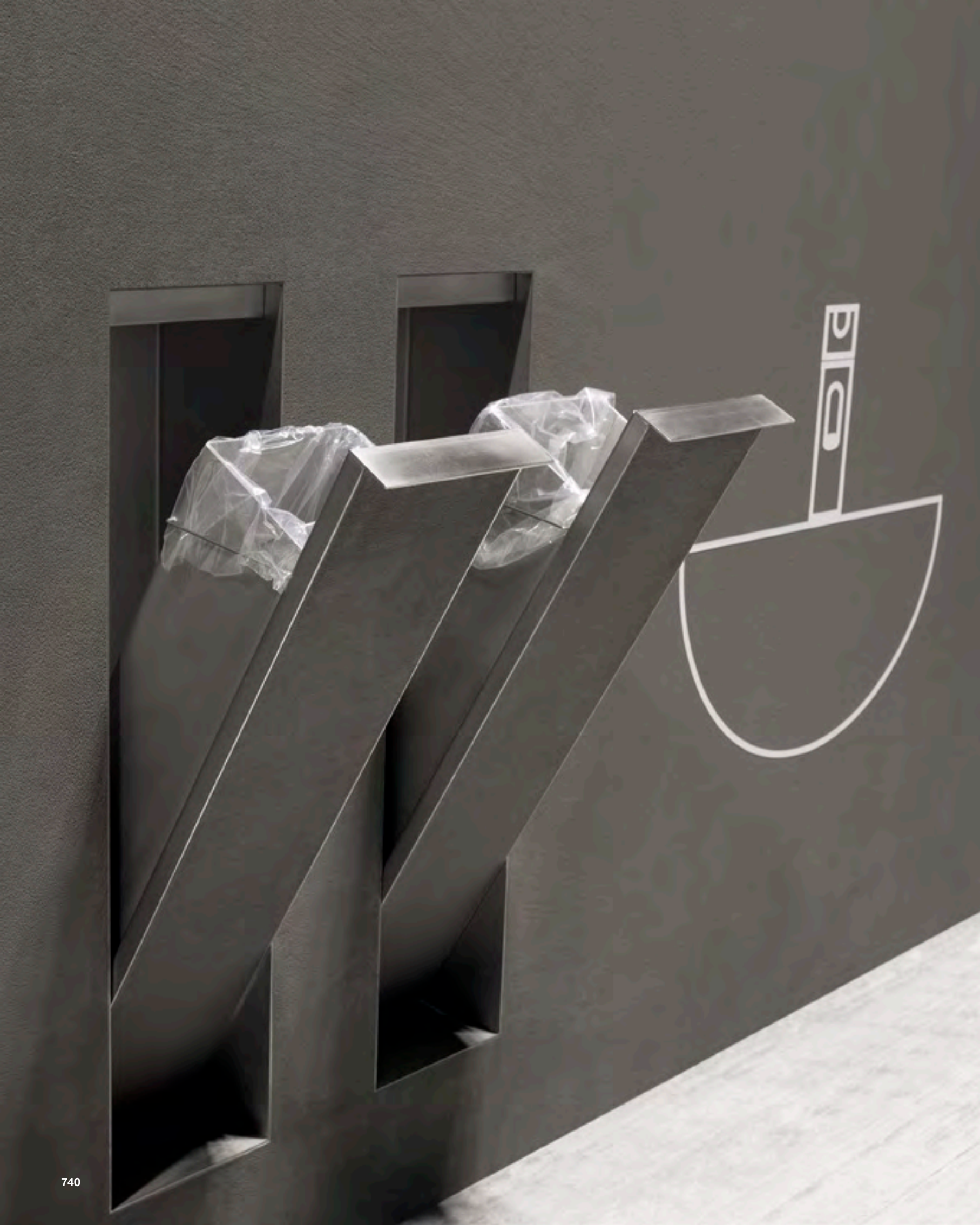



# SESAMO



accessori  
accessories





Sesamo è una collezione innovativa che supera il concetto di accessori per il bagno in modo radicale, li mantiene invisibili per poi renderli disponibili al momento dell'utilizzo. Le nicchie sono realizzate in acciaio inox e possono essere rivestite con lo stesso materiale della parete. Nessun limite per il tipo di finitura, massima igiene e funzionalità.

*Sesamo is an innovative collection that dramatically goes beyond the concept of bathroom accessories, making them invisible yet available only when necessary. The niches are made of stainless steel and can be coated with the same wall material. No limits to the type of finish, maximum hygiene and functionality.*

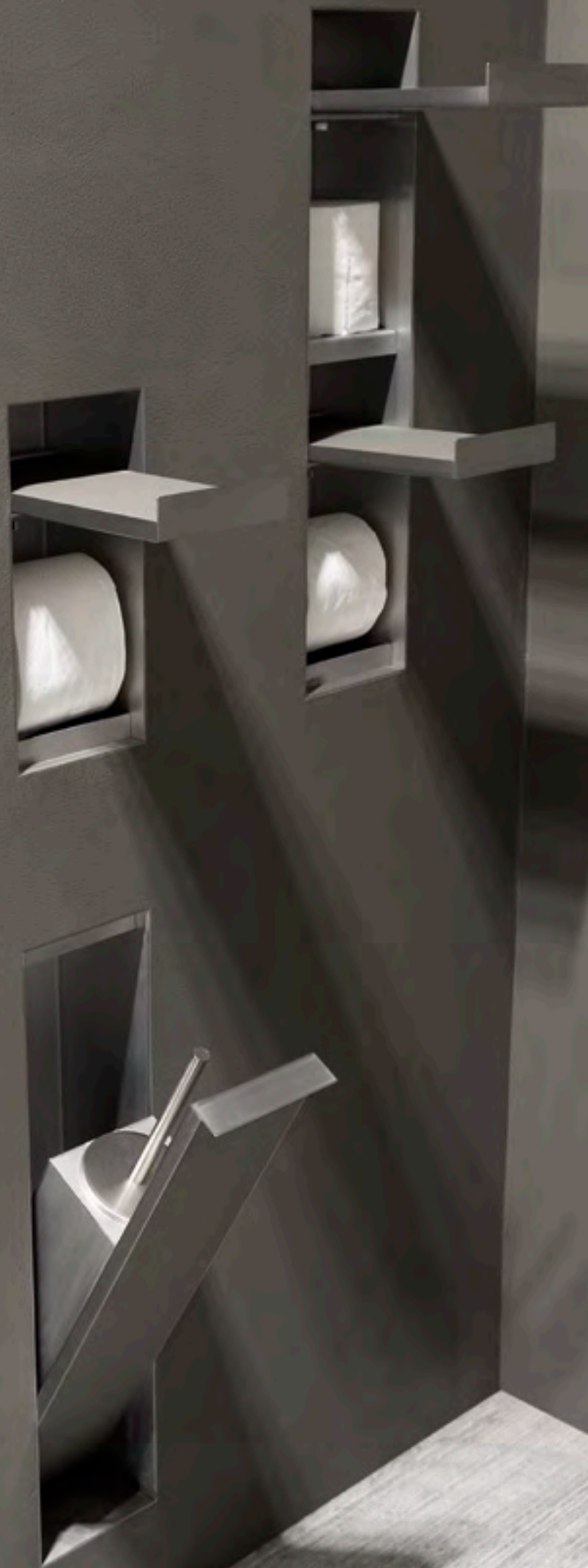



**SESAMO**



acta exteriora indicant interiora secreta





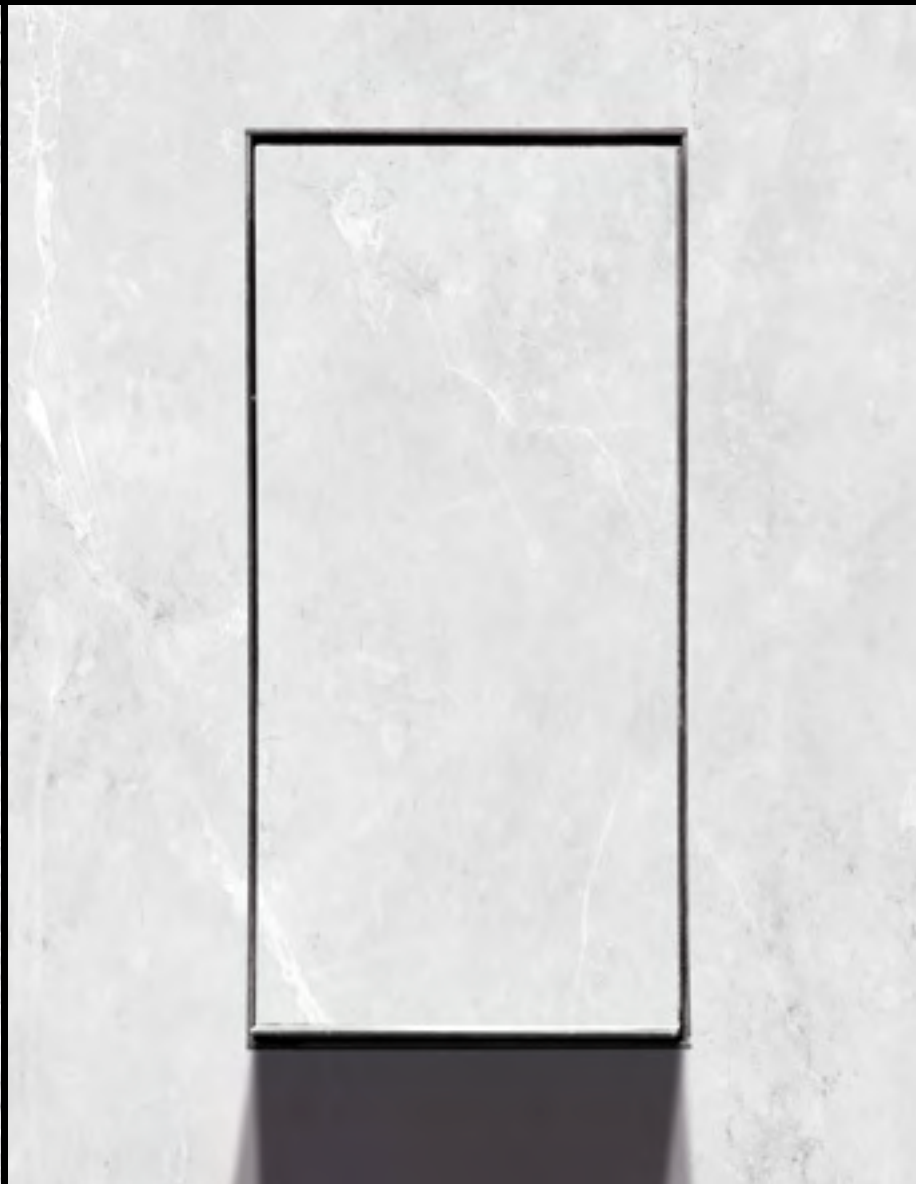



# SESAMO, SENTITEVI LIBERI

FEEL FREE

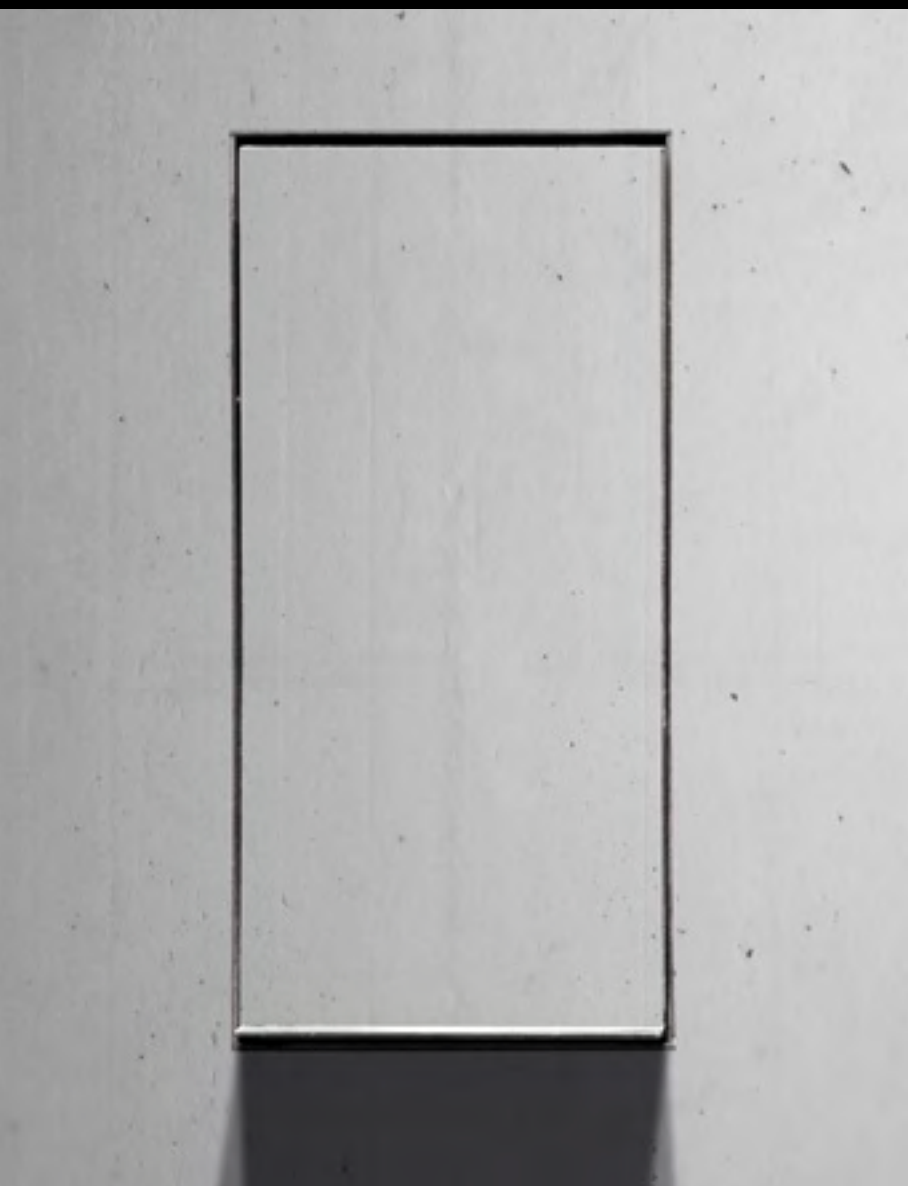

Sentitevi liberi di esprimere il vostro stile, Sesamo si inserisce perfettamente in ogni superficie, diventa pietra, legno, metallo, carta da parati... sentitevi liberi di inventare...

*Feel free to express your style, Sesamo fits perfectly into any surface, like stone, wood, metal, wallpaper... feel free to use your imagination ...*

# SESAMO design Arkimera

Modello e design registrato  
Registered model and design

Applicazione su cartongesso con finitura intonaco  
Application on drywall with plaster finishing

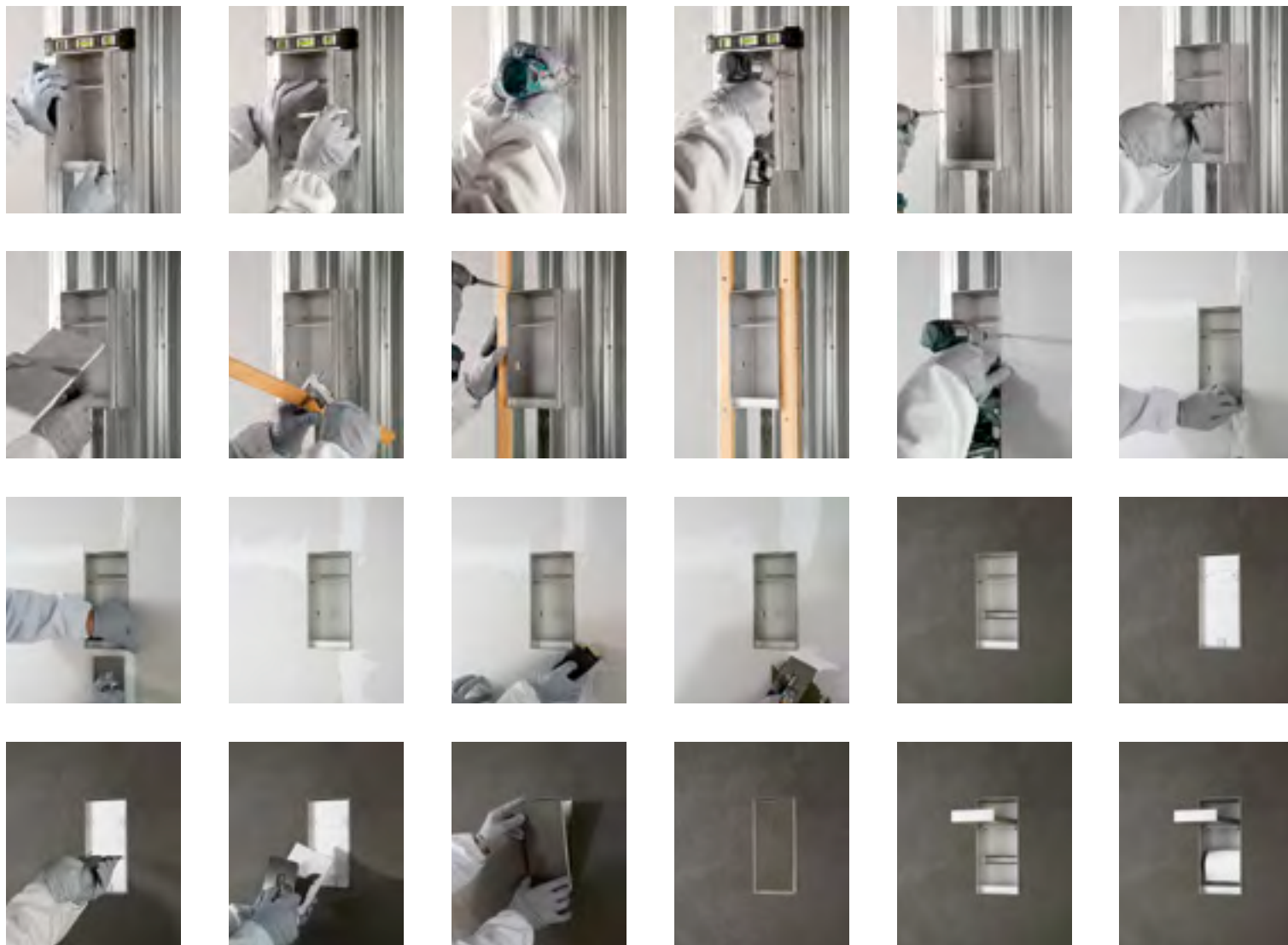

Applicazione su cartongesso con rivestimento marmo  
Application on drywall with marble covering

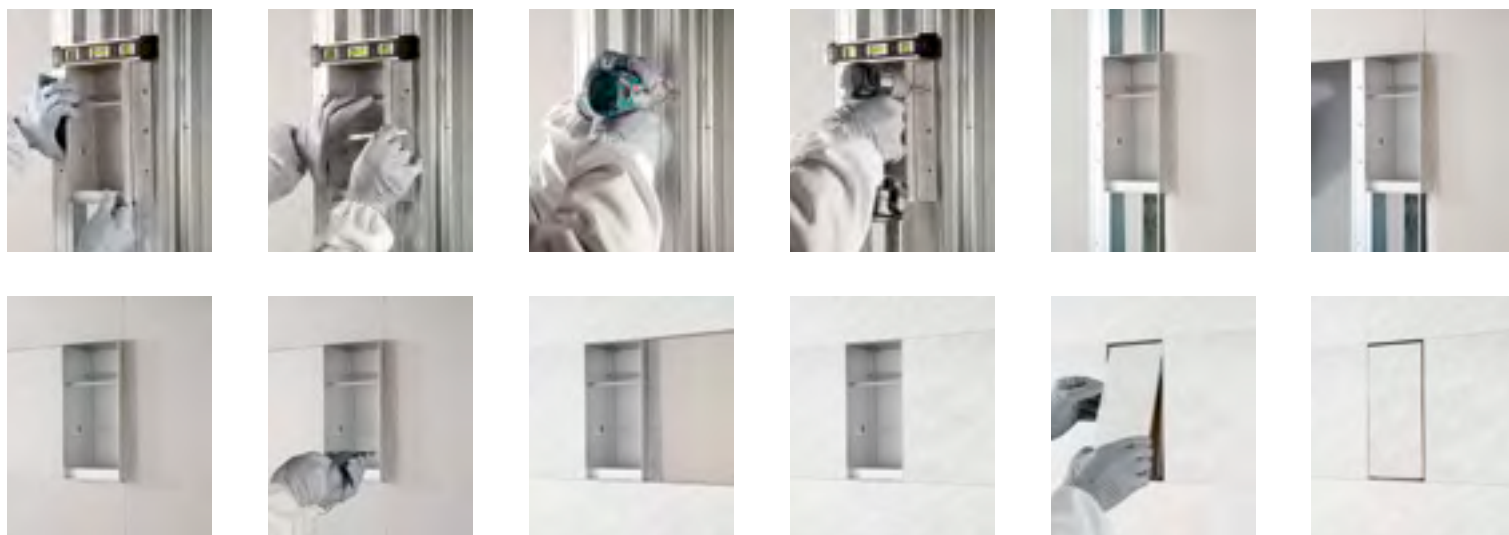

# SESAMO

Appendi abiti da incasso a parete in acciaio inox AISI304 finitura alluminio.

*Encased wall hook in stainless steel AISI 304 with an aluminum finish.*



H	P	L	art.
12,5	5,5	7,3	<b>SESAMO1</b>

Porta carta da incasso a parete in acciaio inox AISI 304 finitura alluminio.

**N.B.** Lo spazio utile interno in profondità è di 8,7 cm.

*Encased toilet paper holder in stainless steel AISI 304 with an aluminum finish.*

**P.S.** The internal useful space is 8,7 cm.



H	P	L	art.
25	10,4	19,8	<b>SESAMO4</b>

Porta dispenser o porta spazzolini da incasso a parete in acciaio inox AISI 304 finitura alluminio.

*Encased soap dispenser in stainless steel AISI 304 with an aluminum finish.*



H	P	L	art.
34	10,4	19,8	<b>SESAMO2</b>

Porta dispenser o porta spazzolini doppio da incasso a parete in acciaio inox AISI 304 finitura alluminio.

Encased double soap dispenser in stainless steel AISI 304 with an aluminum finish.



H	P	L	art.
34	10,4	35	<b>SESAMO3</b>

Porta scopino da incasso a parete in acciaio inox AISI 304 finitura alluminio.

*Encased toilet brush holder in stainless steel AISI 304 with an aluminum finish.*



H	P	L	art.
50	10,4	19,8	<b>SESAMO6</b>

Cestino rifiuti da incasso a parete in acciaio inox AISI 304 finitura alluminio.

*Encased waste basket in stainless steel AISI 304 with an aluminum finish.*



L	P	H	art.
19,8	10,4	50	<b>SESAMO7</b>

Porta carta con scorta da incasso a parete in acciaio inox AISI 304 finitura alluminio.

*Encased toilet paper holder and spare in stainless steel AISI 304 with an aluminum finish.*



H	P	L	art.
50	10,4	19,8	<b>SESAMO5</b>

Armadietto farmacia da incasso a parete in acciaio inox AISI 304 finitura alluminio.

*Encased medicine cabinet in stainless steel AISI 304 with an aluminum finish.*



H	P	L	art.
25	10,4	44	<b>SESAMO8</b>









TAPE









TAPE





accessori  
accessories





# TAPE



accessori  
accessories

**TAPE 72**



**TAPE 54**



**TAPE 45**



**TAPE 36**



**TAPE 27**

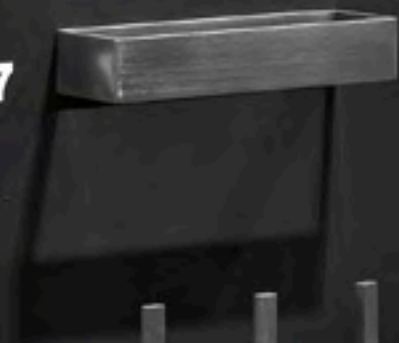

**TAPE 113**



**TAPE** ...per esempio...  
...for example...

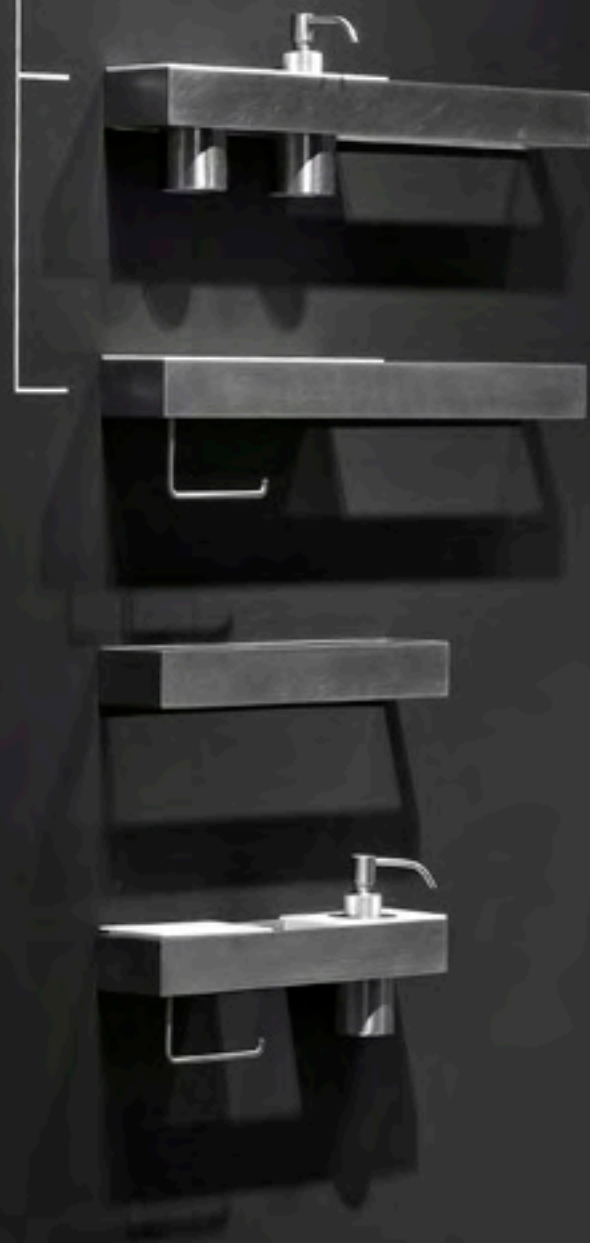



# TAPE

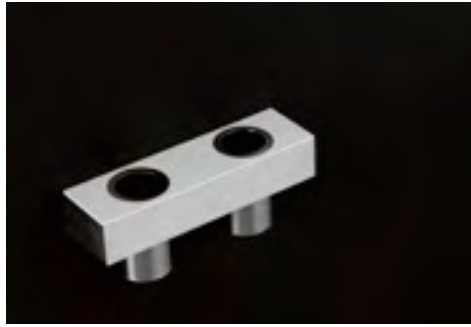
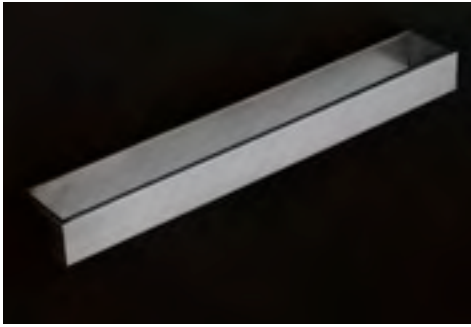

accessori  
accessories

# TAPE



Appendi abiti singolo a parete in acciaio inox satinato AISI 304.

*Satin stainless steel AISI 304 clothes hook.*

H	P	L	art.
6	8	8	<b>TAPE106</b>



Bicchiere da appoggio o da incasso per pianetti Corian in acciaio inox satinato AISI 304.

*Freestanding or encased cup in satin stainless steel AISI 304 for Corian surfaces.*

H	P	Ø	art.
10,5	6,5	6,5	<b>TAPE102</b>



Appendi abiti doppio a parete in acciaio inox satinato AISI 304.

*Double satin stainless steel AISI 304 clothes hook.*

H	P	L	art.
6	8	16	<b>TAPE107</b>



Porta scopino da appoggio in resina bianca e manico in acciaio inox satinato AISI 304.

*Toilet brush and white resin holder with a satin stainless steel AISI 304 handle.*

H	P	Ø	art.
44	8	8	<b>TAPE113</b>



Dispenser sapone liquido da appoggio o da incasso per pianetti Corian in acciaio inox satinato AISI 304.

*Freestanding or encased soap dispenser in satin stainless steel AISI 304 for Corian surfaces.*

H	P	Ø	art.
16	9,5	6,5	<b>TAPE101</b>

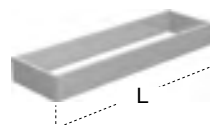

Porta salviette in acciaio inox satinato AISI 304.

*Satin stainless steel AISI 304 towel rack.*

H	P	L	art.
5	8	27	<b>TAPE27</b>
5	8	36	<b>TAPE36</b>
5	8	45	<b>TAPE45</b>
5	8	54	<b>TAPE54</b>
5	8	72	<b>TAPE72</b>



Pianetto liscio in Corian.

*Corian surface.*

H	P	L	art.
1,2	8	13,5	<b>TAPE1</b>



Pianetto liscio in Corian dx o sx reversibile, con portarotolo in acciaio inox satinato AISI 304.

*Corian surface right or left with satin stainless steel AISI 304 paper roll holder.*

H	P	L	art.
12	8	13,5	<b>TAPE2</b>

# TAPE



Porta sapone in Corian.  
*Corian soap dish.*

H	P	L	art.
1,2	8	13,5	<b>TAPE3</b>



Pianetto in Corian liscio.  
*Corian surface.*

H	P	L	art.
1,2	8	27	<b>TAPE11</b>



Porta sapone in Corian dx o sx reversibile, con portarotolo in acciaio inox satinato AISI 304.  
*Corian soap dish right or left with satin stainless steel AISI 304 paper roll holder.*

H	P	L	art.
12	8	13,5	<b>TAPE4</b>



Pianetto in Corian con foro per bicchiere o dispenser.  
*Corian surface with hole for cup or dispenser.*

H	P	L	art.
1,2	8	27	<b>TAPE12</b>



Pianetto in Corian con foro per bicchiere o dispenser.  
*Corian surface with hole for cup or dispenser.*

H	P	L	art.
1,2	8	13,5	<b>TAPE5</b>



Pianetto in Corian con 2 fori per bicchiere o dispenser.  
*Corian surface with 2 holes for cup or dispenser.*

H	P	L	art.
1,2	8	27	<b>TAPE13</b>



Pianetto in Corian con griglia.  
*Grided Corian surface.*

H	P	L	art.
1,2	8	13,5	<b>TAPE6</b>



Pianetto in Corian con griglia.  
*Grided Corian surface.*

H	P	L	art.
1,2	8	27	<b>TAPE14</b>



**PLAY** design AL Studio

Tutta la serie PLAY é realizzata in acciaio inox lucido AISI 304.  
*The PLAY series is produced in polished stainless steel AISI 304.*





accessori  
accessories

PLAY

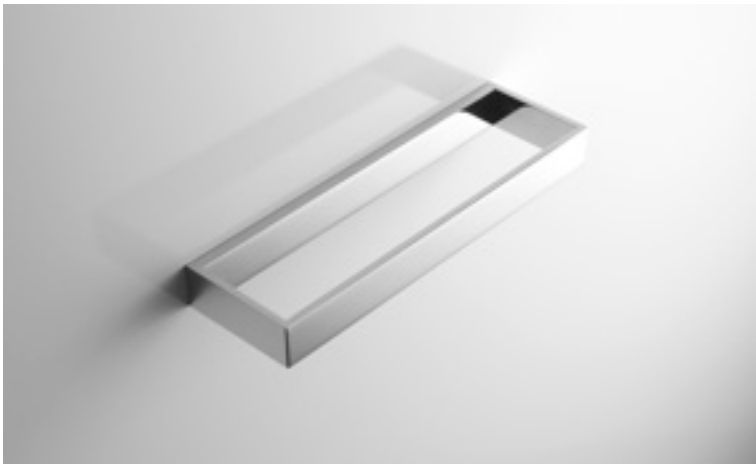



PLAY

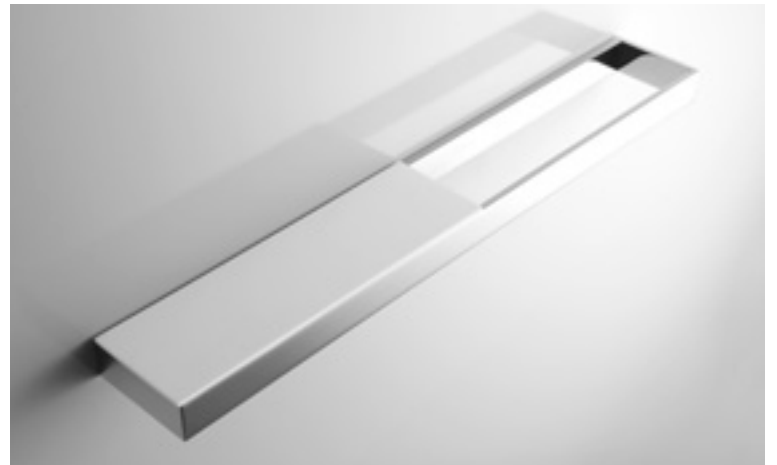
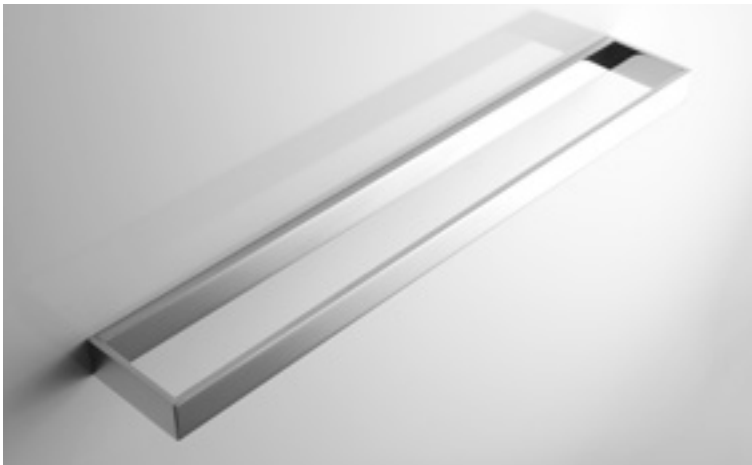

accessori  
accessoires

# PLAY

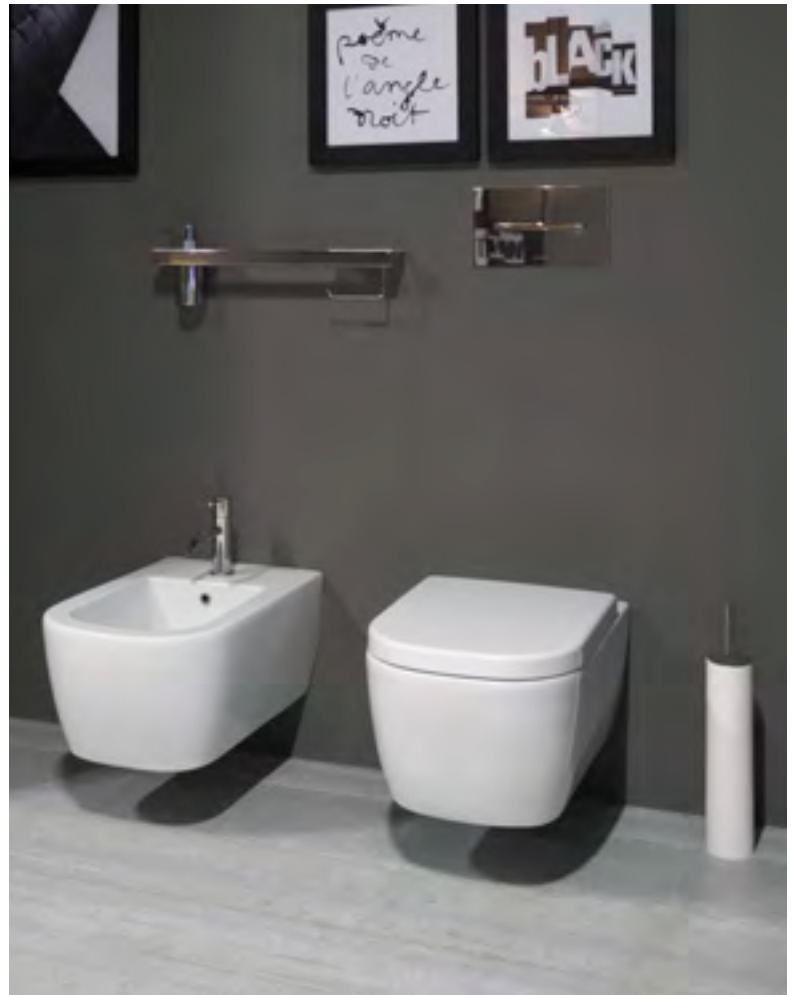





# PLAY



Appendi abiti singolo a parete in acciaio inox lucido AISI 304.

*Polished stainless steel AISI 304 clothes hook.*

H	P	L	art.
3	8	6	<b>PLAY106</b>



Appendi abiti doppio a parete in acciaio inox lucido AISI 304.

*Double polished stainless steel AISI 304 clothes hook.*

H	P	L	art.
3	8	12	<b>PLAY107</b>



Dispenser sapone liquido da appoggio o da incasso per pianetti Corian in acciaio inox lucido AISI 304.

*Freestanding or encased soap dispenser for Corian surfaces in polished stainless steel AISI 304.*

H	P	Ø	art.
16	9,5	6,5	<b>PLAY101</b>



Bicchieri da appoggio o da incasso per pianetti Corian in acciaio inox lucido AISI 304.

*Freestanding or encased cup for Corian surfaces in polished stainless steel AISI 304.*

H	P	Ø	art.
10,5	6,5	6,5	<b>PLAY102</b>



Porta scopino da appoggio in resina bianca e manico in acciaio inox lucido AISI 304.

*Toilet brush and white resin holder with a polished stainless steel AISI 304 handle.*

H	P	Ø	art.
44	8	8	<b>PLAY113</b>

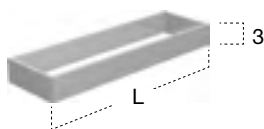

Porta salviette in acciaio inox lucido AISI 304.

*Polished stainless steel AISI 304 towel rack.*

H	P	L	art.
3	8	27	<b>PLAY27</b>
3	8	40	<b>PLAY40</b>
3	8	54	<b>PLAY54</b>
3	8	72	<b>PLAY72</b>



Pianetto liscio in Corian.

*Corian surface.*

H	P	L	art.
1,2	8	13,5	<b>TAPE1</b>



Pianetto liscio in Corian dx o sx reversibile, con portarotolo in acciaio inox lucido AISI 304.

*Corian surface with right or left polished stainless steel AISI 304 paper roll holder.*

H	P	L	art.
10	8	13,5	<b>PLAY2</b>



Porta sapone in Corian.

*Corian soap dish.*

H	P	L	art.
1,2	8	13,5	<b>TAPE3</b>



Porta sapone in Corian dx o sx reversibile, con portarotolo in acciaio inox lucido AISI 304.

*Corian soap dish with right or left polished stainless steel AISI 304 paper roll holder.*

H	P	L	art.
10	8	13,5	<b>PLAY4</b>



Pianetto in Corian con foro per bicchiere o dispenser.

*Corian surface with hole for cup or dispenser.*

H	P	L	art.
1,2	8	13,5	<b>TAPE5</b>



Pianetto in Corian con griglia.

*Gridded Corian surface.*

H	P	L	art.
1,2	8	13,5	<b>TAPE6</b>



Pianetto in Corian liscio.

*Corian surface.*

H	P	L	art.
1,2	8	27	<b>TAPE11</b>



Pianetto in Corian con foro per bicchiere o dispenser.

*Corian surface with hole for cup or dispenser.*

H	P	L	art.
1,2	8	27	<b>TAPE12</b>



Pianetto in Corian con 2 fori per bicchiere o dispenser.

*Corian surface with 2 holes for cup or dispenser.*

H	P	L	art.
1,2	8	27	<b>TAPE13</b>

# PLAY



Pianetto in Corian con griglia.  
*Grided Corian surface.*

H	P	L	art.
1,2	8	27	<b>TAPE14</b>



Bicchieri da appoggio in resina bianca.  
*White resin cup.*

H	P	Ø	art.
12	8	8	<b>JUST1</b>



Porta sapone da appoggio in resina bianca.  
*White resin soap dish.*

H	P	L	art.
3	8	12	<b>JUST3</b>



Dispenser sapone liquido da appoggio in resina bianca e acciaio inox lucido AISI 304.  
*White and polished stainless steel AISI 304 resin soap dispenser.*

H	P	Ø	art.
19	11	8	<b>PLAY6</b>



Bicchiere in resina bianca con supporto a parete in acciaio inox lucido AISI 304.  
*White resin cup with polished stainless steel AISI 304 wall support.*

H	P	Ø	art.
15	11,2	8	<b>PLAY11</b>



Dispenser sapone liquido in resina bianca con supporto a parete in acciaio inox lucido AISI 304.  
*White resin soap dispenser with polished stainless steel AISI 304 wall support.*

H	P	Ø	art.
22	14,2	8	<b>PLAY14</b>



Piantana porta carta, porta salviette doppio in acciaio inox lucido AISI 304.  
*Freestanding polished stainless steel AISI 304 double paper roll or towel rack.*

H	P	L	art.
60	21,5	33	<b>PLAY108</b>



Piantana porta carta, porta salviette doppio in acciaio inox lucido AISI 304 con porta scopino in resina bianca.  
*Freestanding polished stainless steel AISI 304 double paper roll or towel rack with white resin toilet brush and holder.*

H	P	L	art.
60	21,5	33	<b>PLAY136</b>



Porta salviette da terra con due aste, in acciaio inox lucido AISI 304.  
*Freestanding polished stainless steel AISI 304 towel rack with two arms.*

H	P	L	art.
81	18	36	<b>PLAY109</b>







accessori  
accessoires

RETTA











# RETTA

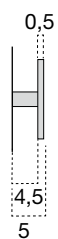

Porta salviette in alluminio verniciato bianco, nero opaco o colorato gofrato come da nostra cartella colori laccati.

*Towel holder in aluminium lacquered matt white, black or embossed as per our colour chart.*

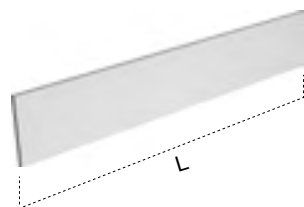

H	P	L	art.
8	5	27	RETTA427
8	5	36	RETTA436
8	5	45	RETTA445
8	5	54	RETTA454
8	5	72	RETTA472
8	5	90	RETTA490
8	5	108	RETTA4108

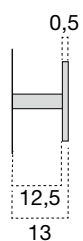

Porta salviette in alluminio verniciato bianco, nero opaco o colorato gofrato come da nostra cartella colori laccati.

*Towel holder in aluminium lacquered matt white, black or embossed as per our colour chart.*

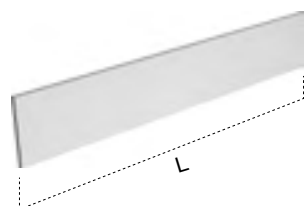

H	P	L	art.
8	13	54	RETTA1254
8	13	72	RETTA1272
8	13	90	RETTA1290
8	13	108	RETTA12108









accessori  
accessoires



QGINI

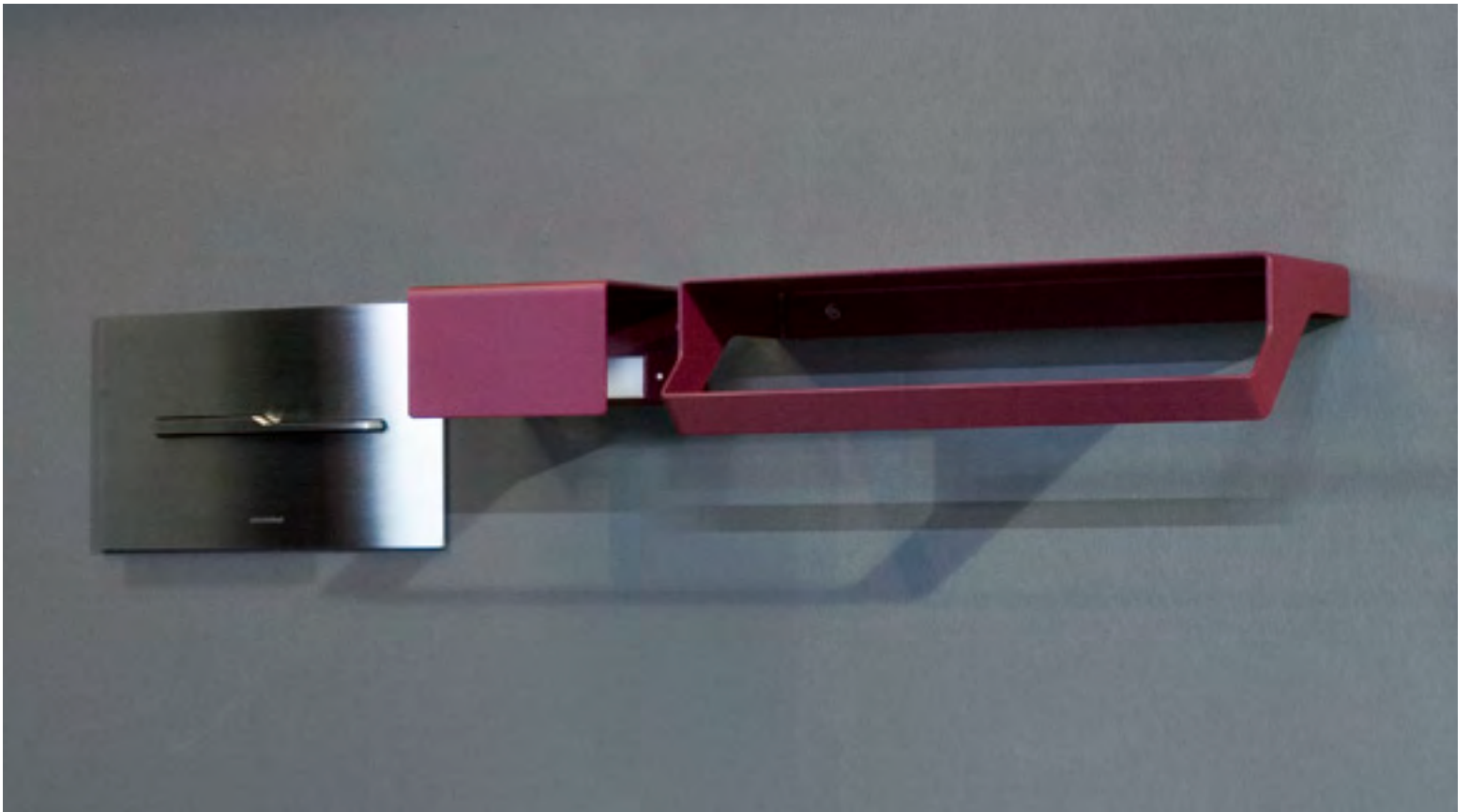

accessori  
accessoires





## QGINI



Appendi abiti a parete in acciaio inox AISI 304, verniciato bianco opaco o colorato gofrato come da nostra cartella colori laccati.

*Wall clothes hook in lacquered stainless steel AISI 304 lacquered matt white or embossed as per our colour chart.*

H	P	L	art.
8	4	7,3	<b>QGINI107</b>

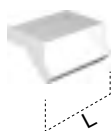

Mensola con porta salviette in acciaio inox AISI 304, verniciato bianco opaco o colorato gofrato come da nostra cartella colori laccati.

*Shelf with towel holder in stainless steel AISI 304 lacquered matt white or embossed as per our colour chart.*

H	P	L	art.
9,2	14,7	36	<b>QGINI36</b>
9,2	14,7	45	<b>QGINI45</b>
9,2	14,7	54	<b>QGINI54</b>



Porta salviette con portarotolo in acciaio inox AISI 304, verniciato bianco opaco o colorato gofrato come da nostra cartella colori laccati.

*Shelf with paper holder in stainless steel AISI 304 lacquered matt white or embossed as per our colour chart.*

H	P	L	art.
9,2	14,7	13,5	<b>QGINI3</b>



Portarotolo in acciaio inox AISI 304, verniciato bianco opaco o colorato gofrato come da nostra cartella colori laccati.

*Paper holder in stainless steel AISI 304 lacquered matt white or embossed as per our colour chart.*

H	P	L	art.
7,8	13	13,5	<b>QGINI4</b>



Mensola con porta salviette in acciaio inox AISI 304, verniciata bianco opaco o colorato gofrato come da nostra cartella colori laccati.

*Shelf with towel holder in stainless steel AISI 304 lacquered matt white or embossed as per our colour chart.*

H	P	L	art.
11,3	27	63	<b>QGINI5</b>



Porta scopino da appoggio in acciaio inox AISI 304, verniciato bianco opaco o colorato gofrato come da nostra cartella colori laccati.

*Toilet brush and holder in stainless steel AISI 304 lacquered matt white or embossed as per our colour chart.*

H	Ø	art.
45	11	<b>QGINI113</b>





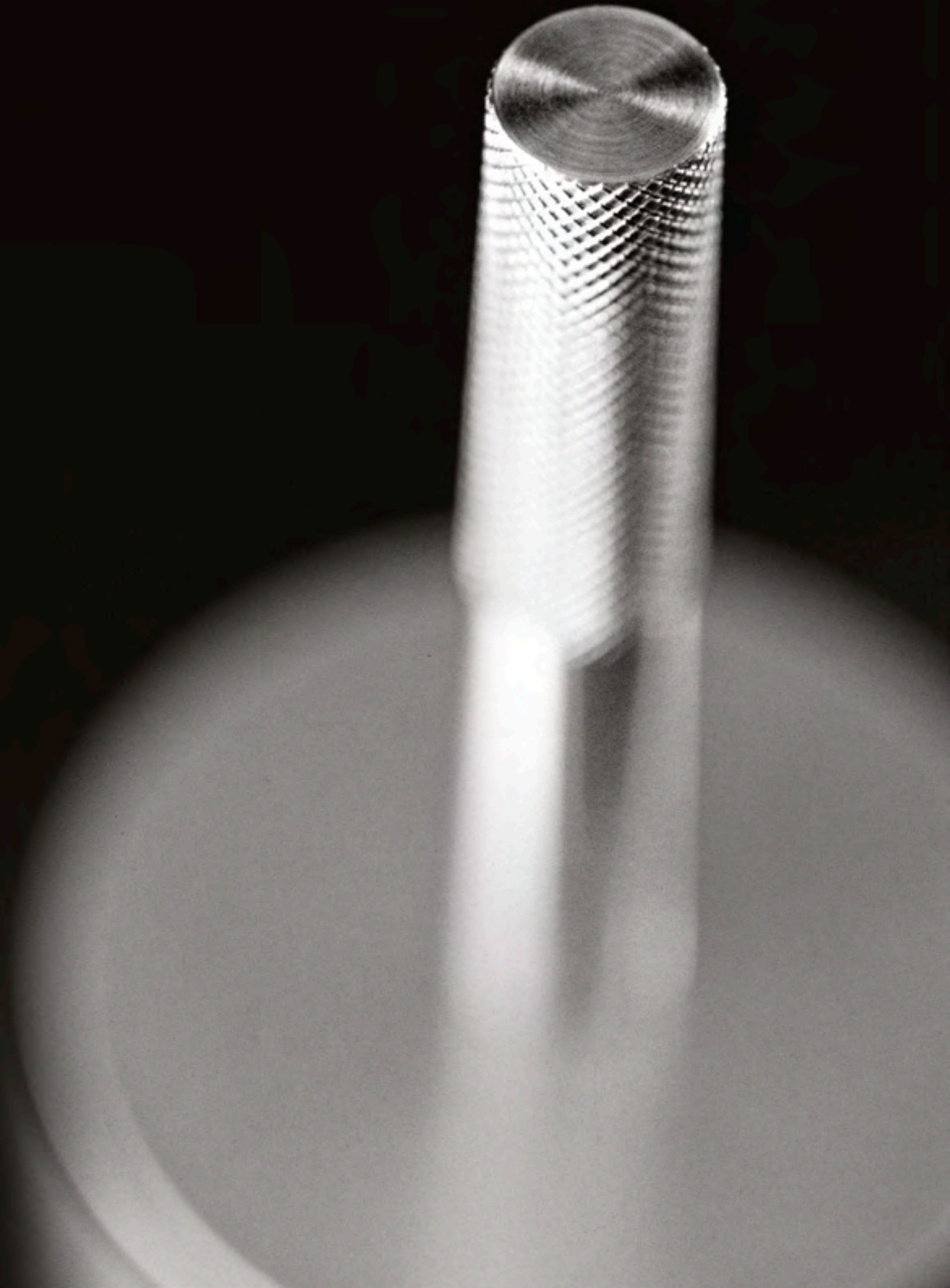



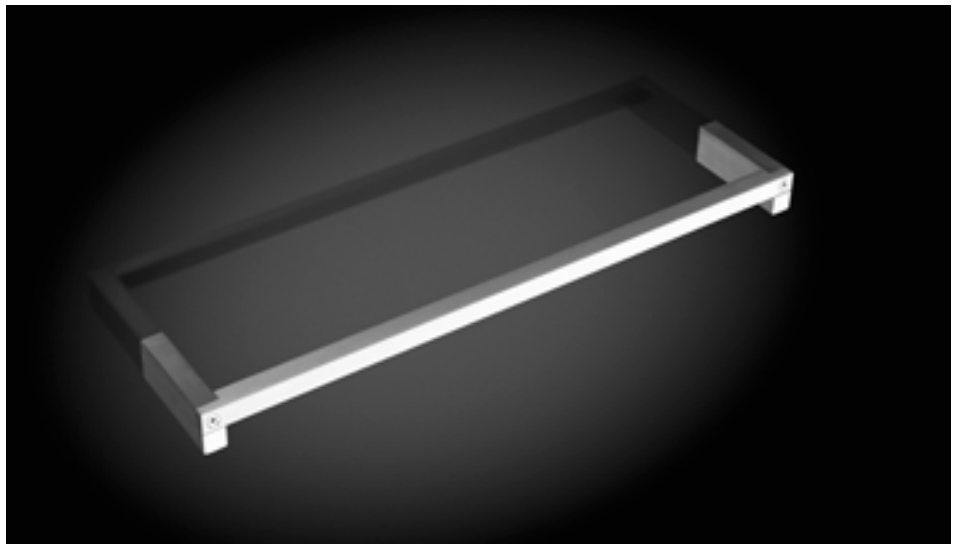
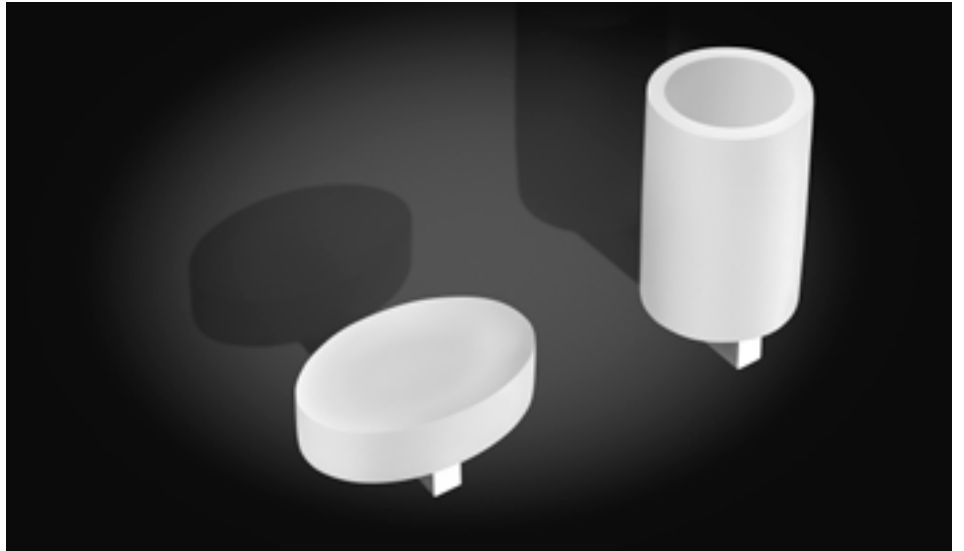

accessori  
accessoires



JUST

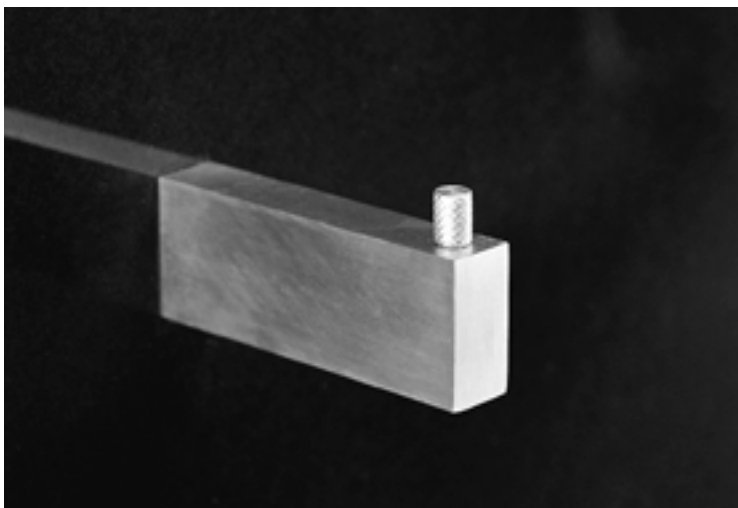
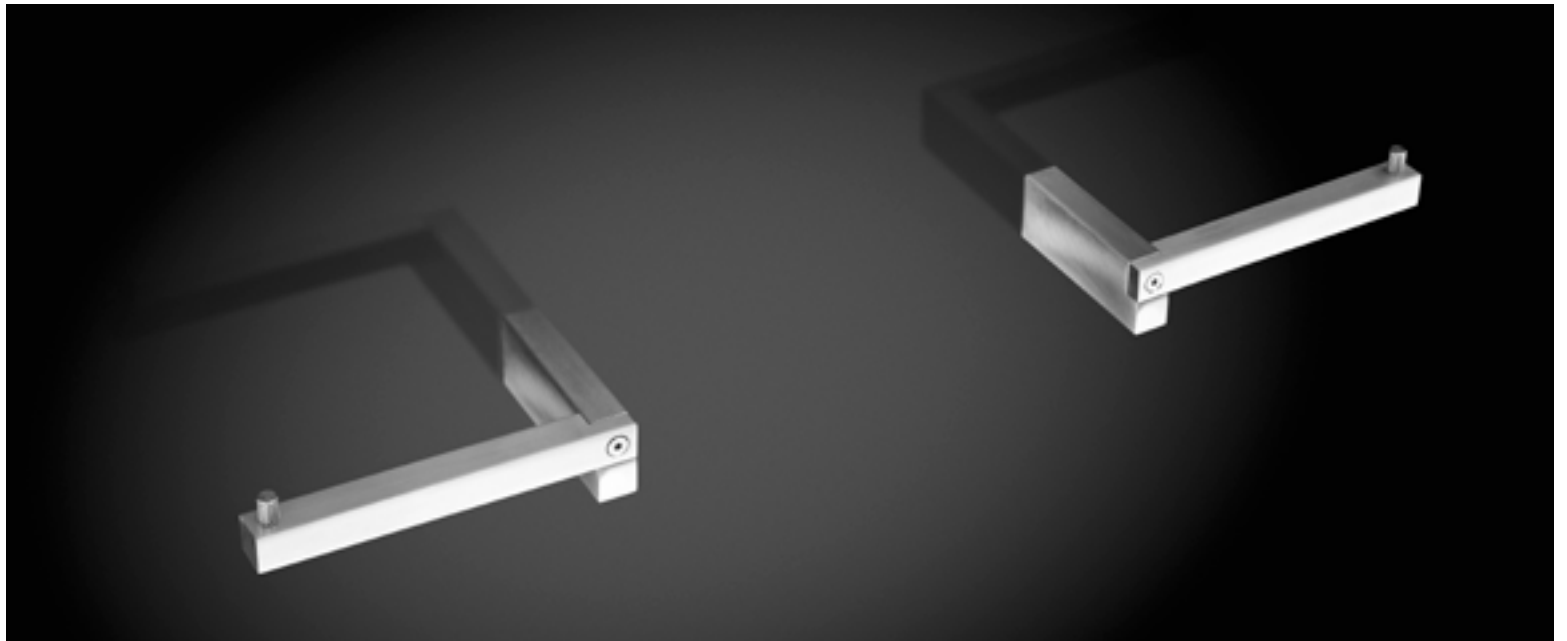
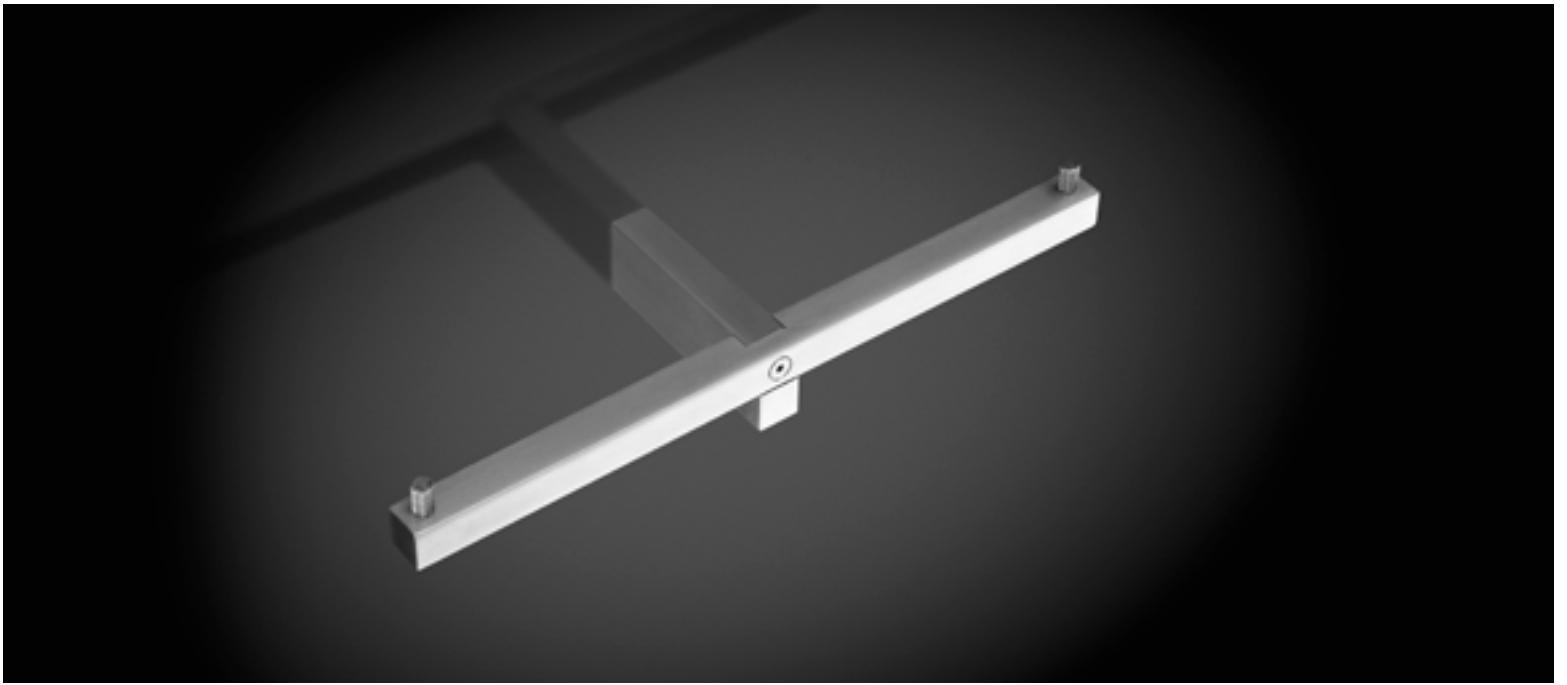

accessori  
accessoires



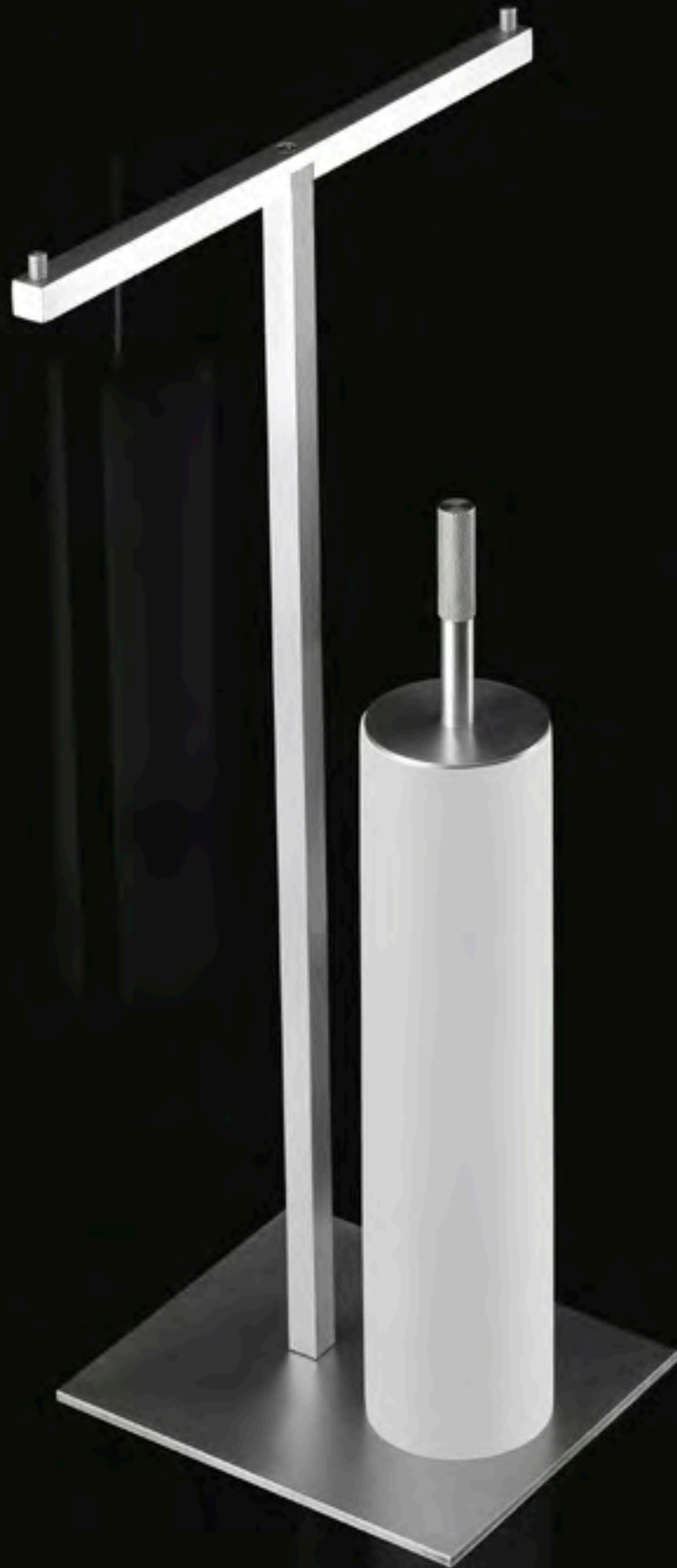

JUST



accessori  
accessories





JUST



accessori  
accessoires

# JUST



Bicchiere da appoggio in resina bianca.  
*White resin cup.*

H	P	Ø	art.
12	8	8	<b>JUST1</b>



Dispenser sapone liquido in resina bianca con supporto a parete in acciaio inox satinato AISI 304.

*White resin soap dispenser with satin stainless steel AISI 304 wall support.*

H	P	Ø	art.
22	14,2	8	<b>JUST14</b>



Porta sapone da appoggio in resina bianca.  
*White resin soap dish.*

H	P	L	art.
3	8	12	<b>JUST3</b>



Porta carta o porta salviette a parete, dx o sx, in acciaio inox satinato AISI 304.

*Satin stainless steel AISI 304 right or left wall mount paper roll holder.*

H	P	L	art.
3	8	17	<b>JUST8</b>

Versione sx - Left version



Dispenser sapone liquido da appoggio in resina bianca e acciaio inox satinato AISI 304.

*White resin and satin stainless steel AISI 304 soap dispenser.*

H	P	Ø	art.
19	11	8	<b>JUST4</b>



Porta carta o porta salviette doppio a parete in acciaio inox satinato AISI 304.

*Satin stainless steel AISI 304 double wall mount towel rod or paper roll holder.*

H	P	L	art.
3	8	26,5	<b>JUST18</b>



Porta scopino da appoggio in resina bianca e manico in acciaio inox satinato AISI 304.

*White resin and satin stainless steel AISI 304 toilet brush and holder.*

H	P	Ø	art.
44	8	8	<b>JUST6</b>



Appendi abiti a parete in acciaio inox satinato AISI 304.

*Satin stainless steel AISI 304 clothes hook.*

H	P	L	art.
3	8	1,5	<b>JUST7</b>



Bicchiere in resina bianca con supporto a parete in acciaio inox satinato AISI 304.

*White resin cup with satin stainless steel AISI 304 wall support.*

H	P	Ø	art.
15	11,2	8	<b>JUST11</b>



Appendi abiti doppio a parete in acciaio inox satinato AISI 304.

*Double satin stainless steel AISI 304 clothes hook.*

H	P	L	art.
3	8	8	<b>JUST17</b>

# JUST

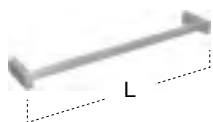

Porta salviette a parete in acciaio inox satinato AISI 304.

*Satin stainless steel AISI 304 wall mount towel rack.*

H	P	L	art.
3	8	45	<b>JUST9</b>
3	8	60	<b>JUST19</b>



Piantana porta carta, porta salviette doppio in acciaio inox satinato AISI 304.

*Freestanding satin stainless steel AISI 304 double paper roll or towel rack.*

H	P	L	art.
60	21,5	33	<b>JUST108</b>



Piantana porta carta, porta salviette doppio in acciaio inox satinato AISI 304 con porta scopino in resina bianca.

*Freestanding satin stainless steel AISI 304 double paper roll or towel rack with white resin toilet brush and holder.*

H	P	L	art.
60	21,5	33	<b>JUST106</b>



Porta salviette da terra con due aste, in acciaio inox satinato AISI 304.

*Freestanding satin stainless steel AISI 304 towel rack with two arms.*

H	P	L	art.
81	18	36	<b>JUST109</b>





# TANDEM-UP design AL Studio



H	P	L	art.
167	15	72	<b>TANDEM-UP</b>

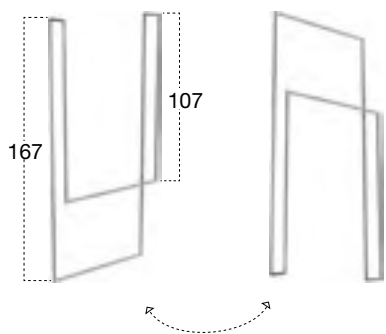

Porta salviette doppio da terra o da soffitto con struttura tubolare 15 x 15 mm in acciaio inox satinato AISI 304.

*Double towel rack freestanding or hanging with 15 x 15 mm satin stainless steel AISI 304 tubular structure.*



H	P	L	art.
80	15	54	<b>TANDEMSA</b>
80	15	54	<b>TANDEMLU</b>

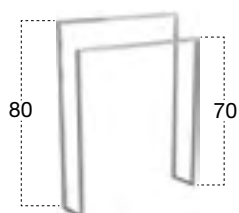

Porta salviette doppio da terra con struttura tubolare 15 x 15 mm in acciaio inox AISI 304 satinato o lucido.

*Double freestanding towel rack with 15 x 15 mm satin or polished stainless steel AISI 304 tubular structure.*







H	P	L	art.
81	23,5	81,5	<b>RACK</b>

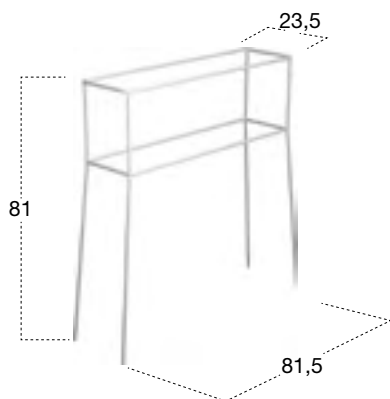

Porta salviette in acciaio AISI 304, verniciato bianco opaco o colorato gofrato come da nostra cartella colori laccati.

*Towel holder in steel AISI 304, lacquered matt white or embossed as per our colour chart.*









H	P	L	art.
65	40	30	<b>GINO1</b>
75	40	30	<b>GINO2</b>

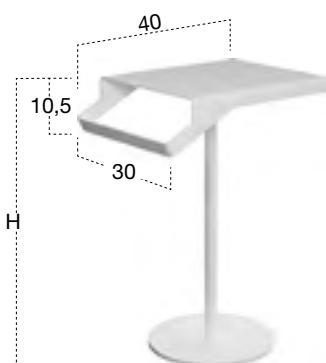

Tavolino porta oggetti con porta salviette in acciaio inox AISI 304 verniciato bianco o colorato gofrato come da nostra cartella colori laccati.

*Stainless steel AISI 304 table with towel rail lacquered matt white, black or embossed as per our colour chart.*







H	Ø	art.
68,5	36	LINO1
78,5	36	LINO2

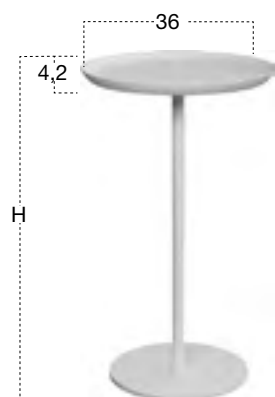

Tavolino porta oggetti con piano in Cristalplant biobased e piedistallo in acciaio inox AISI 304 verniciato bianco o colorato gofrato come da nostra cartella colori laccati.

*Table for objects with a biobased Cristalplant surface and stainless steel AISI 304 base lacquered matt white or embossed as per our colour chart.*





art. BILLO

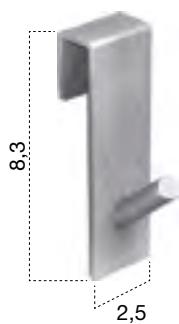

Appendi abiti singolo in acciaio inox satinato AISI 304 per vetri box doccia.

*Single clothes hook in satin stainless steel AISI 304 suitable for shower enclosures.*





art. TAO H 4,6 P 32 L 36 cm

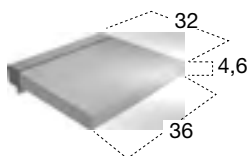

Seggetta reclinabile con fissaggio a parete in acciaio inox lucido AISI 304 e seduta di colore bianco in poliuretano morbido.

*Reclinable white soft poliurethane seat with polished stainless steel AISI 304 wall supports.*

**BIG BAG** design Riccardo Fattori



art. **BIG BAG** H 45 P 30 L 50 cm

**campionario colori - colour samples**

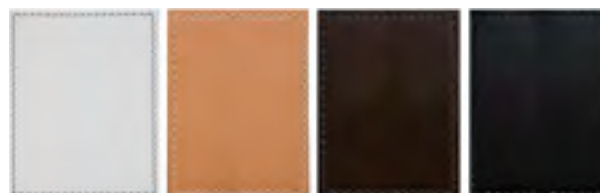

avana

naturale

testa di moro

nero

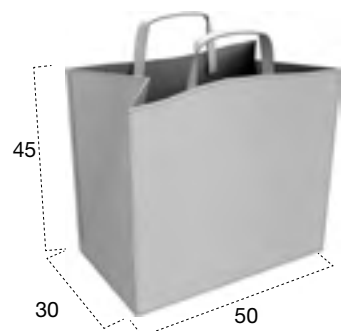

Cesto porta biancheria in cuoio rigenerato, in diversi colori come da nostro campionario.

*Linen bag in various colours of bonded leather as per our samples.*



**GRID BAG** design Riccardo Fattori



art. GRID BAG H 45 P 30 L 50 cm

campionario colori - colour samples



nero

mastice

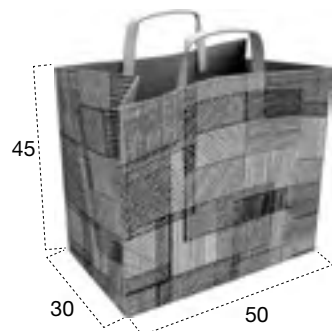

Vista fronte e lato sx - Front view and left side



Vista retro e lato dx - Back view and right side

Cesto porta biancheria in cuoio rigenerato con decoro sul fronte e su fianco sx, in diversi colori come da nostro campionario.

Linen bag in bonded leather, with decoration on front and left side, in various colours as per our samples.







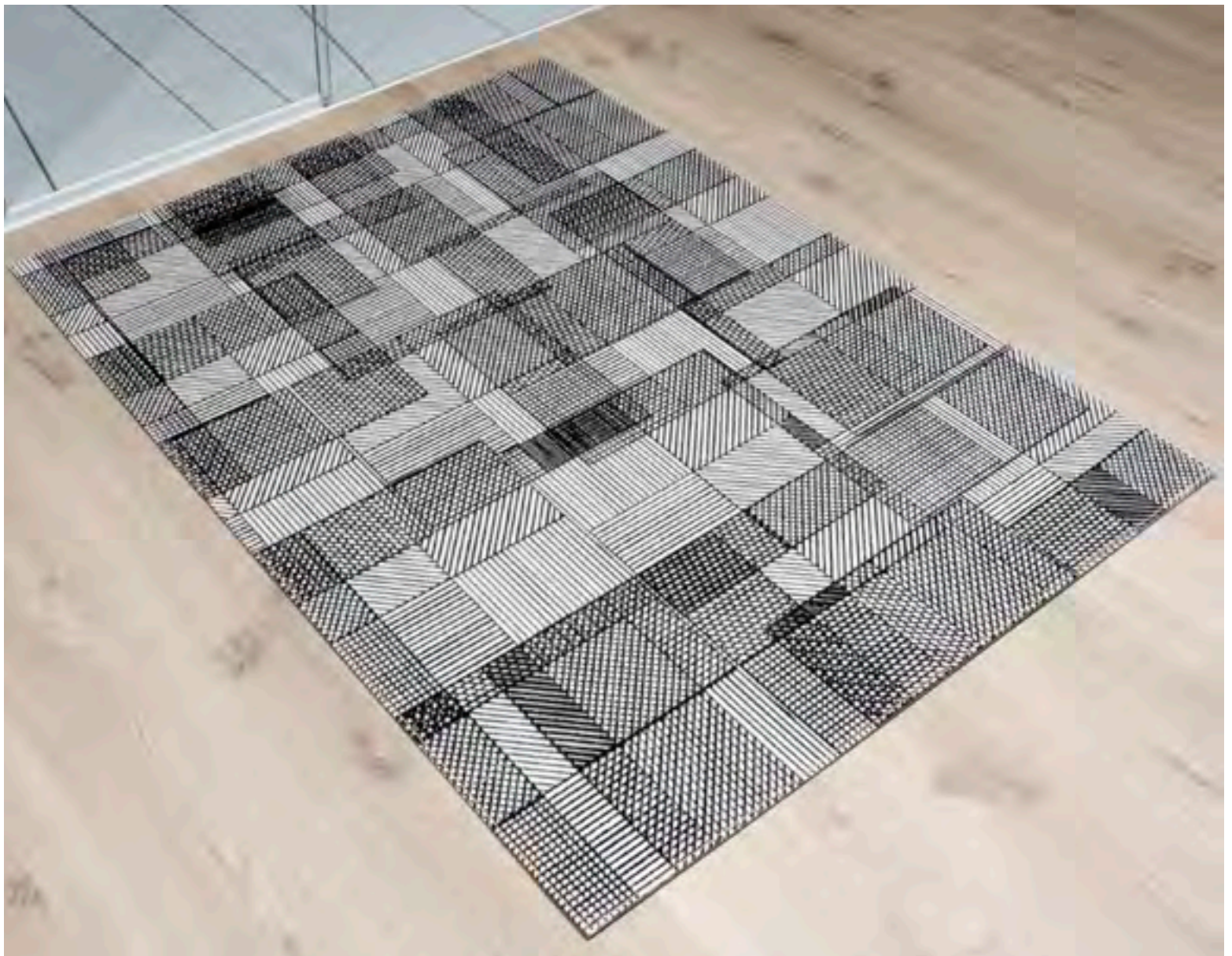

- art. **GRID90** P 60 L 90
- art. **GRID120** P 90 L 120
- art. **GRID90N** P 60 L 90 con neoprene / with neoprene
- art. **GRID120N** P 90 L 120 con neoprene / with neoprene

**campionario colori - colour samples**



nero

mastice

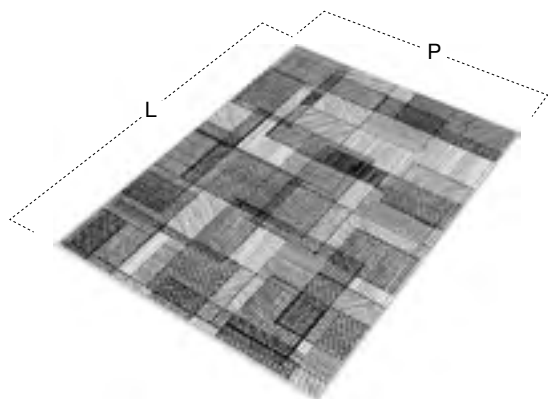

Tappeto decorato in cuoio rigenerato o in cuoio rigenerato montato su neoprene, in diversi colori come da nostro campionario.

*Decorated matt in bonded leather, mounted on neoprene, in various colours as per our samples.*







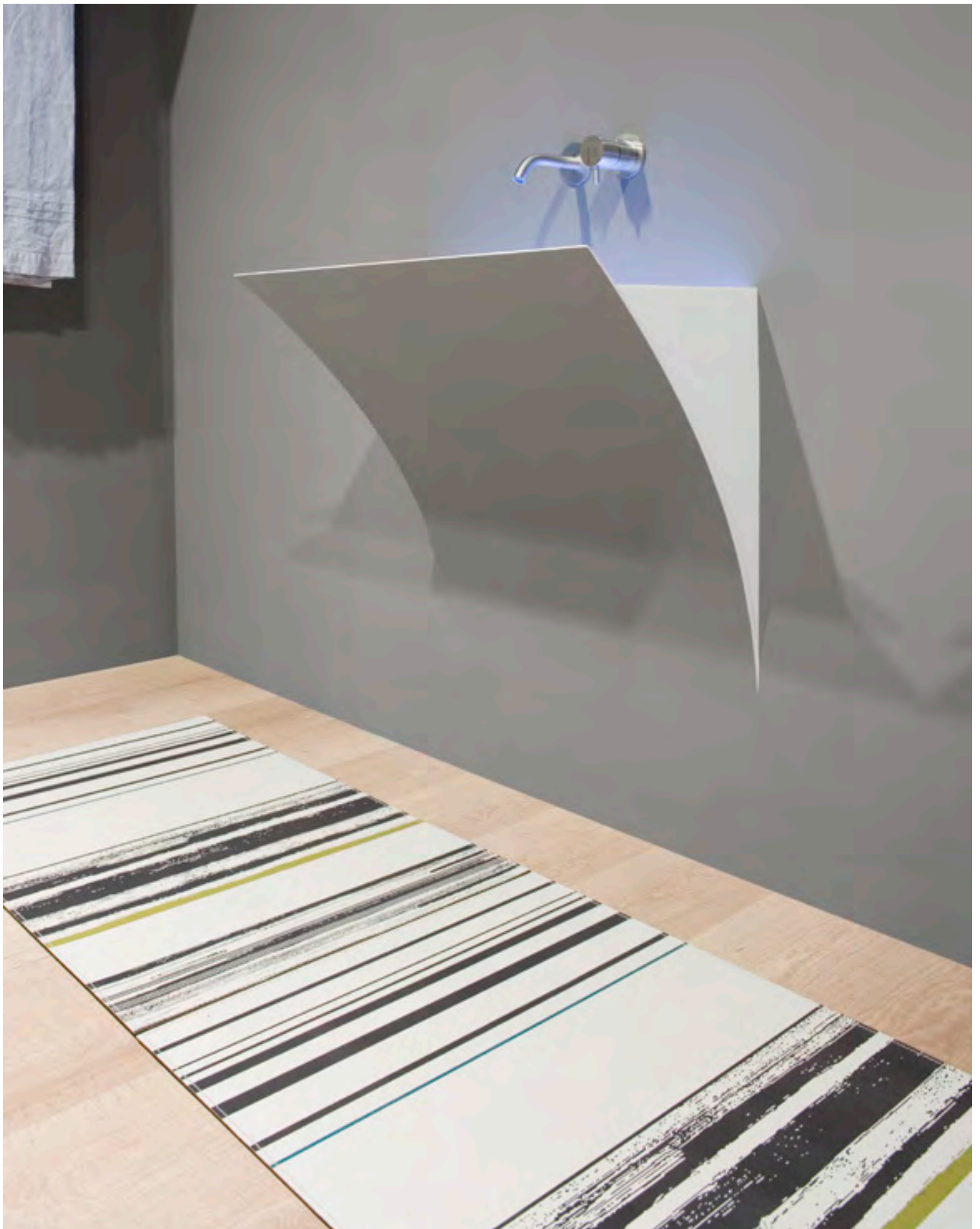



# ARIGHE



# ARIGHE

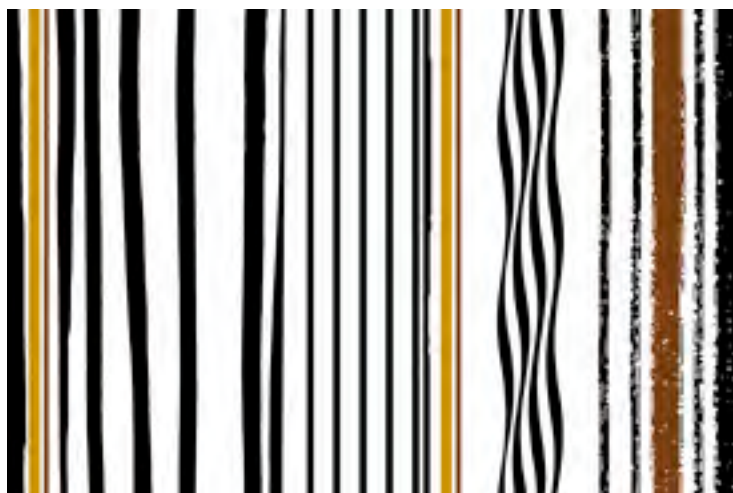

**ARIGHE190N** P 60 L 90 cm  
**ARIGHE1120N** P 90 L 120 cm

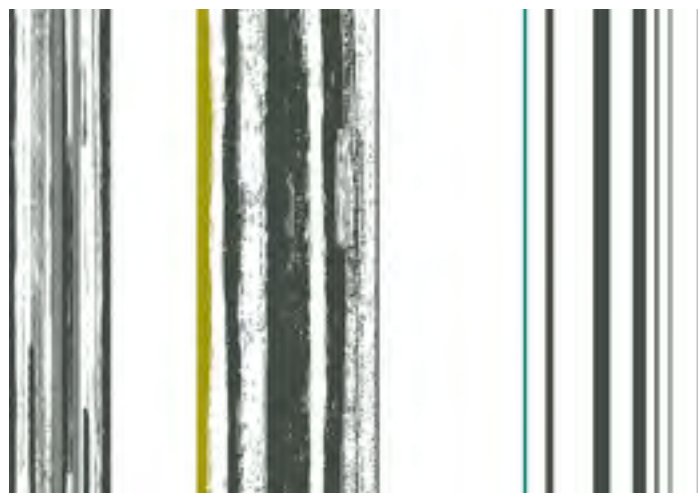

**ARIGHE290N** P 60 L 90 cm  
**ARIGHE2120N** P 90 L 120 cm

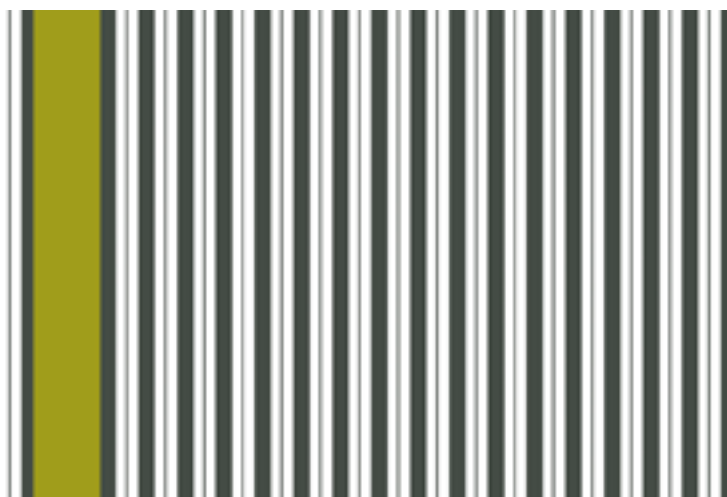

**ARIGHE390N** P 60 L 90 cm  
**ARIGHE3120N** P 90 L 120 cm

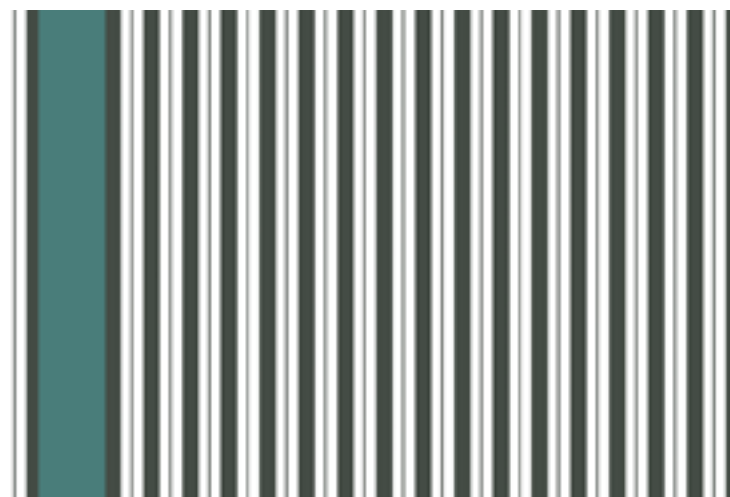

**ARIGHE490N** P 60 L 90 cm  
**ARIGHE4120N** P 90 L 120 cm



**ARIGHE590N** P 60 L 90 cm  
**ARIGHE5120N** P 90 L 120 cm

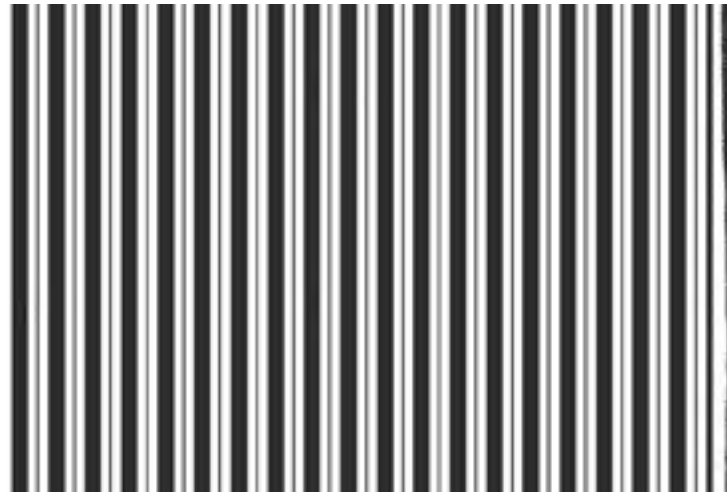

**ARIGHE690N** P 60 L 90 cm  
**ARIGHE6120N** P 90 L 120 cm

Tappeti decorati in cuoio rigenerato montato su neoprene.  
 Decorated mats in bonded leather, mounted on neoprene.







**NOCHINA** design Riccardo Fattori



art. NOCHINA / NOCHINAN P 240 L 180 cm

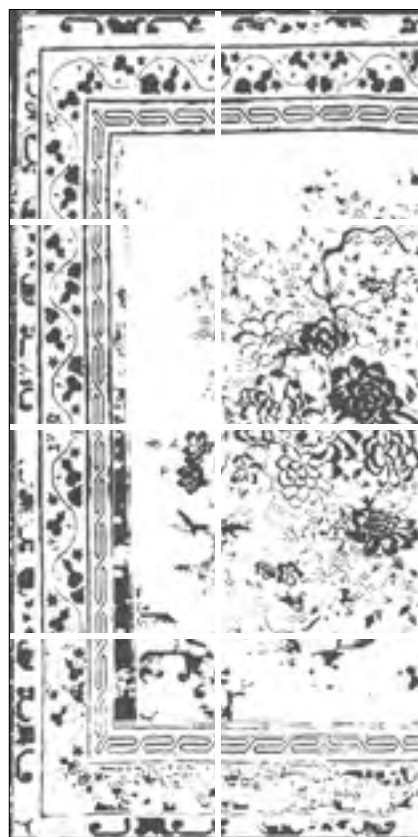

art. NOCHINA / NOCHINAN P 240 L 120 cm

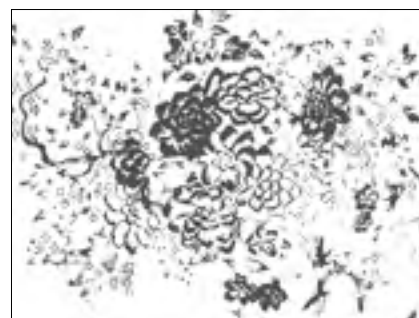

art. NOCHINA120N P 90 L 120 cm

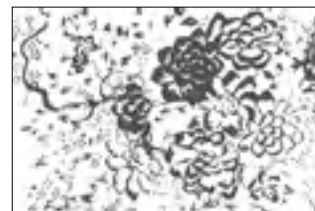

art. NOCHINA90N P 60 L 90 cm



art. NOCHINA / NOCHINAN P 180 L 180 cm



art. NOCHINA / NOCHINAN P 120 L 120 cm

**campionario colori - colour samples**



NERO    GELSO    MELA    AVIO    BORGOGNA ANEMONE    ARENA    BLU CHINA

**art. NOCHINA / NOCHINAN**

Tappeti decorati composti da piastrelle cucite 60 x 60 cm in cuoio rigenerato o in cuoio rigenerato montato su neoprene (N), in diversi colori come da nostro campionario.

*Decorated mats made of sewn tiles 60 x 60 cm in bonded leather or bonded leather mounted on neoprene (N), in various colours as per our samples.*

**art. NOCHINA90N / NOCHINA120N**

Tappeti decorati in cuoio rigenerato montati su neoprene, in diversi colori come da nostro campionario.

*Decorated mats in bonded leather, mounted on neoprene, in various colours as per our samples.*

accessori  
accessoires







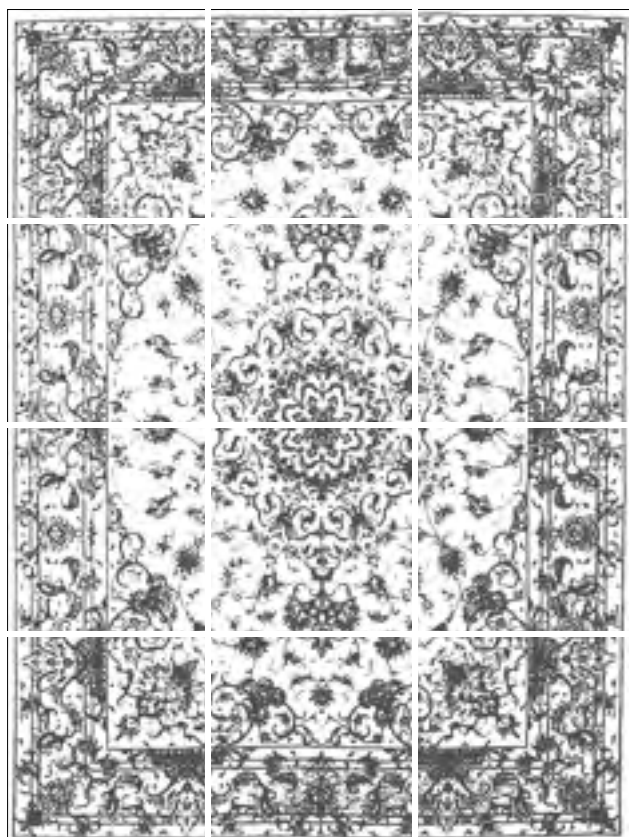

art. NOKIRMAN / NOKIRMANN P 240 L 180 cm

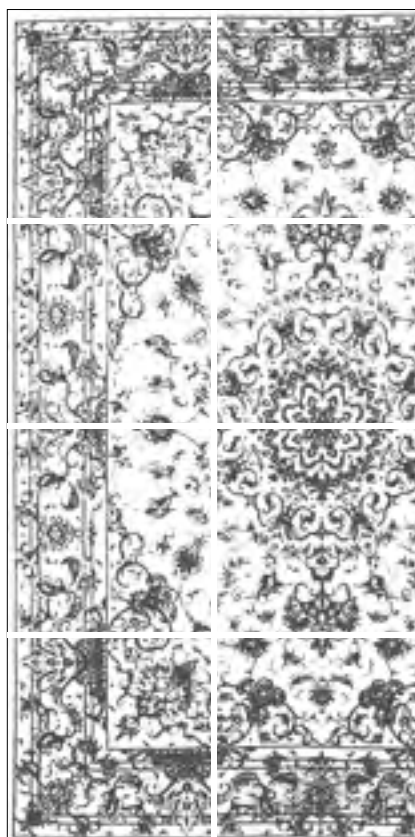

art. NOKIRMAN / NOKIRMANN P 240 L 120 cm

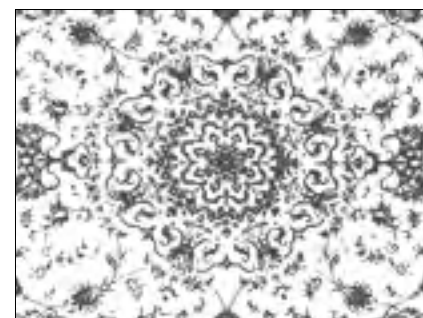

art. NOKIRMAN120N P 90 L 120 cm

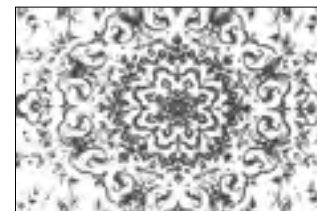

art. NOKIRMAN90N P 60 L 90 cm

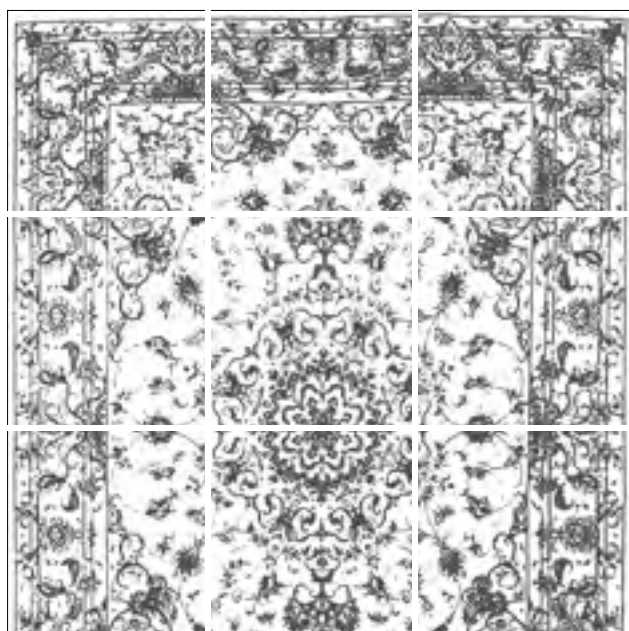

art. NOKIRMAN / NOKIRMANN P 180 L 180 cm

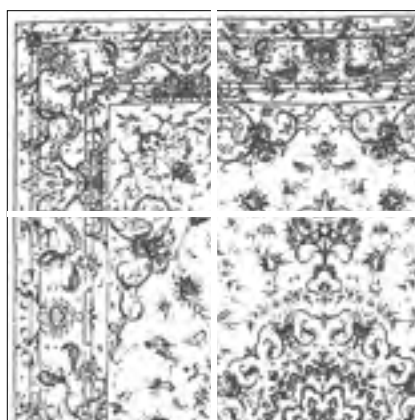

art. NOKIRMAN / NOKIRMANN P 120 L 120 cm

**campionario colori - colour samples**



NERO GELSO MELA AVIO BORGOGNA ANEMONE ARENA BLU CHINA

**art. NOKIRMAN / NOKIRMANN**

Tappeti decorati composti da piastrelle cucite 60 x 60 cm in cuoio rigenerato o in cuoio rigenerato montato su neoprene (N), in diversi colori come da nostro campionario.

*Decorated mats made of sewn tiles 60 x 60 cm in bonded leather or bonded leather mounted on neoprene (N), in various colours as per our samples.*

**art. NOKIRMAN90N / NOKIRMAN120N**

Tappeti decorati in cuoio rigenerato montati su neoprene, in diversi colori come da nostro campionario.

*Decorated mats in bonded leather, mounted on neoprene, in various colours as per our samples.*







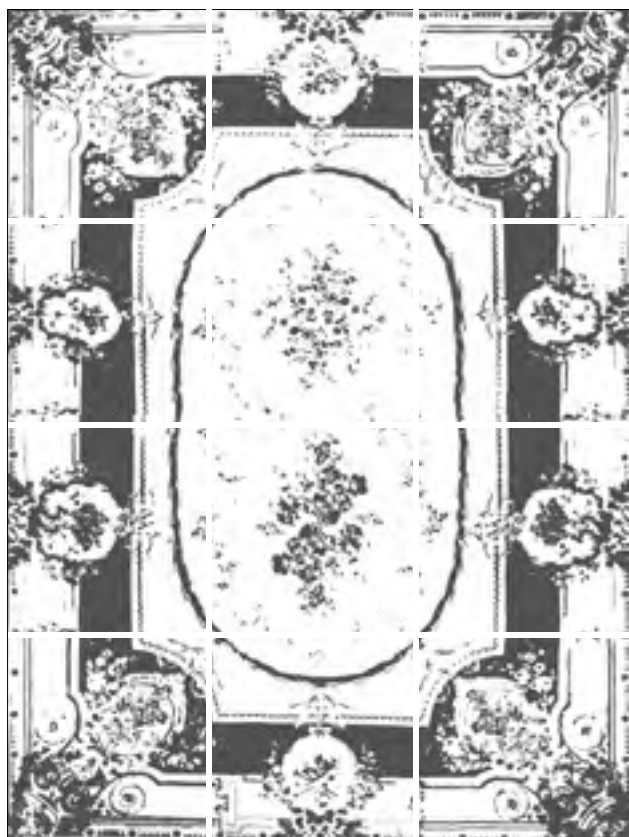

art. NOAUBUSSON / NOAUBUSSONN P 240 L 180 cm

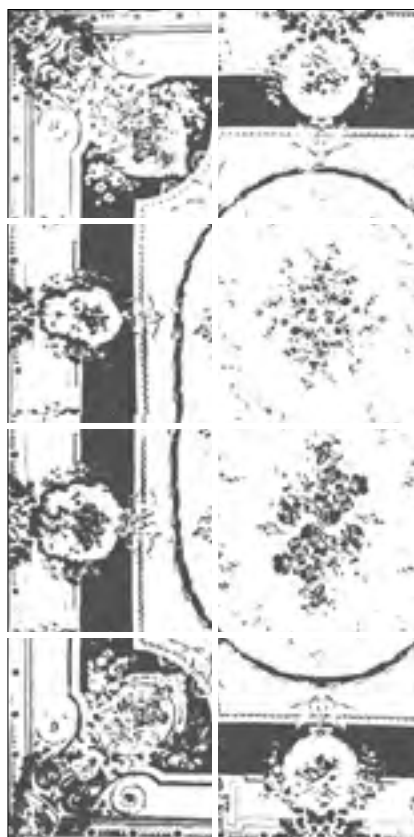

art. NOAUBUSSON / NOAUBUSSONN P 240 L 120 cm

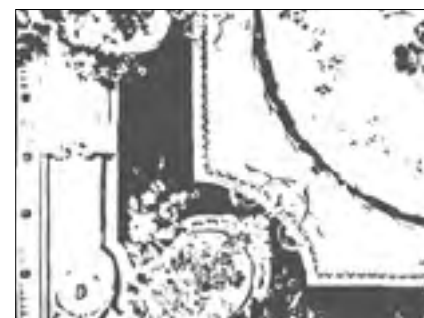

art. NOAUBUSSON120N P 90 L 120 cm



art. NOAUBUSSON90N P 60 L 90 cm

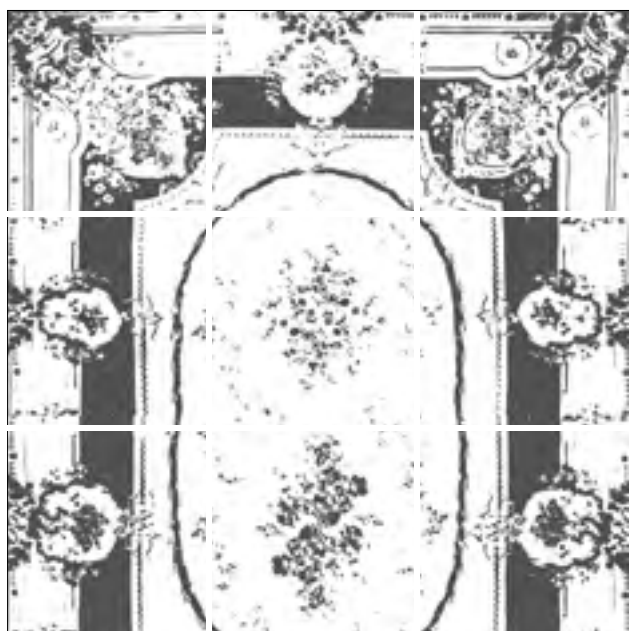

art. NOAUBUSSON / NOAUBUSSONN P 180 L 180 cm

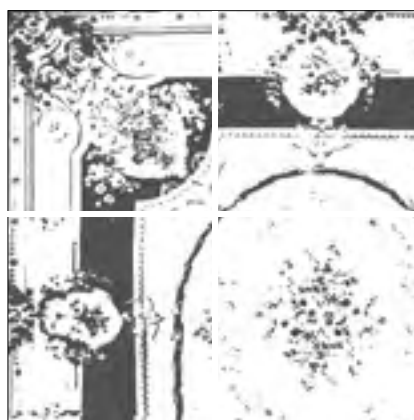

art. NOAUBUSSON / NOAUBUSSONN P 120 L 120 cm

**campionario colori - colour samples**



NERO GELSO MELA AVIO BORGOGNA ANEMONE ARENA BLU CHINA

**art. NOAUBUSSON / NOAUBUSSONN**

Tappeti decorati composti da piastrelle cucite 60 x 60 cm in cuoio rigenerato o in cuoio rigenerato montato su neoprene (N), in diversi colori come da nostro campionario.

*Decorated mats made of sewn tiles 60 x 60 cm in bonded leather or bonded leather mounted on neoprene (N), in various colours as per our samples.*

**art. NOAUBUSSON90N / NOAUBUSSON120N**

Tappeti decorati in cuoio rigenerato montati su neoprene, in diversi colori come da nostro campionario.

*Decorated mats in bonded leather, mounted on neoprene, in various colours as per our samples.*





art. TEOREMA90N

art. TEOREMA120N

campionario colori - colour samples

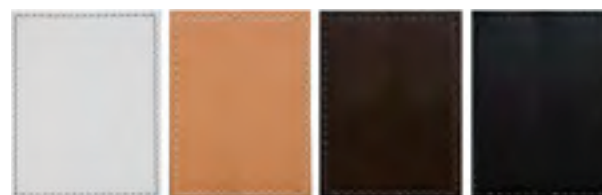

avana

naturale

testa di moro

nero

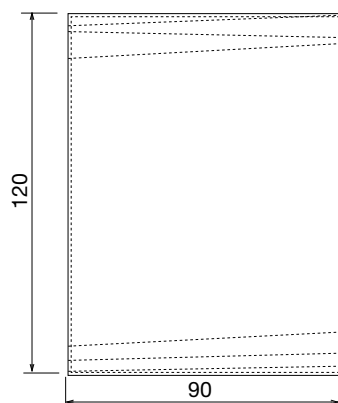
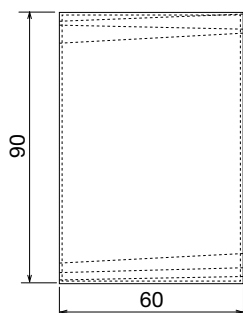

Tappeto in cuoio rigenerato montato su neoprene, in diversi colori come da nostro campionario.

*Mat in bonded leather mounted on neoprene, in various colours as per our samples.*



art. SEZIONI90N

art. SEZIONI120N

campionario colori - colour samples

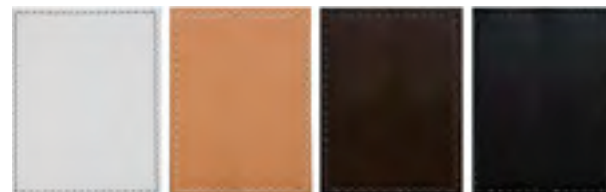
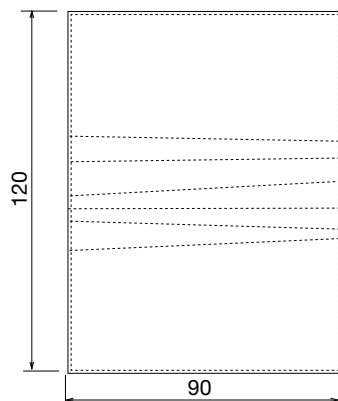
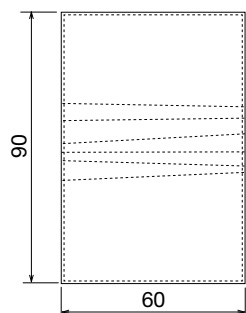

avana naturale testa di moro nero

Tappeto in cuoio rigenerato montato su neoprene, in diversi colori come da nostro campionario.

*Mat in bonded leather mounted on neoprene, in various colours as per our samples.*

accessori  
accessories





antoniolupi



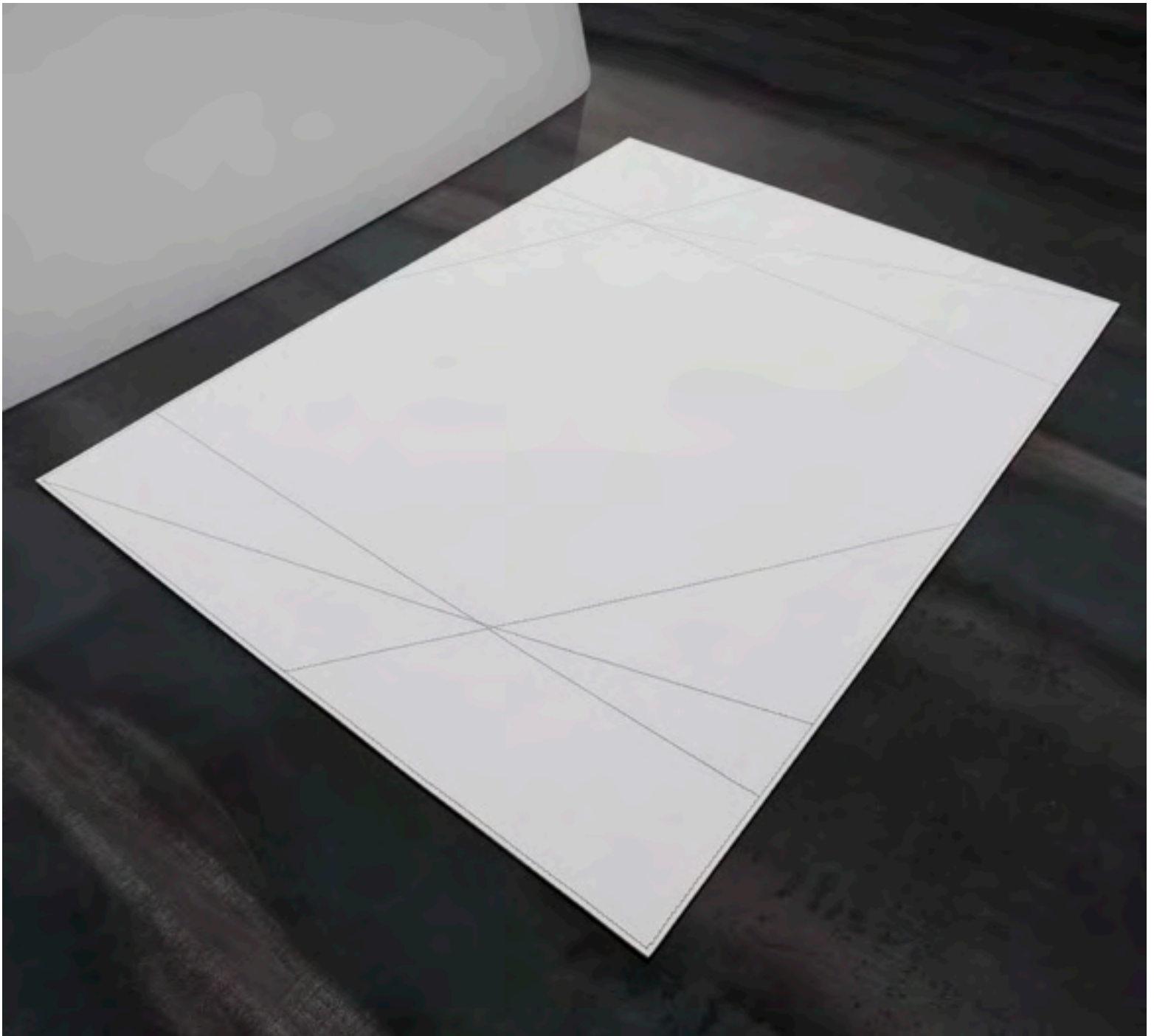

art. POLIGONI90N

art. POLIGONI120N

campionario colori - colour samples

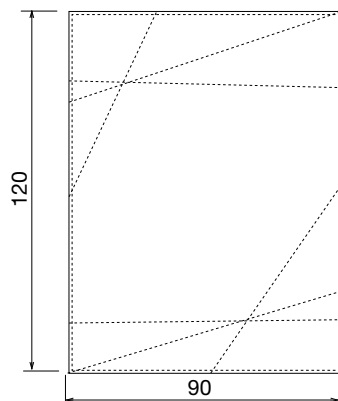
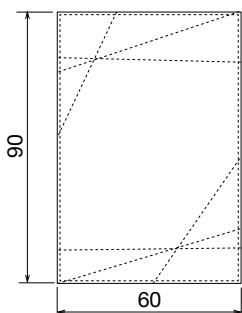

avana

naturale

testa di moro

nero

Tappeto in cuoio rigenerato montato su neoprene, in diversi colori come da nostro campionario.

*Mat in bonded leather mounted on neoprene, in various colours as per our samples.*



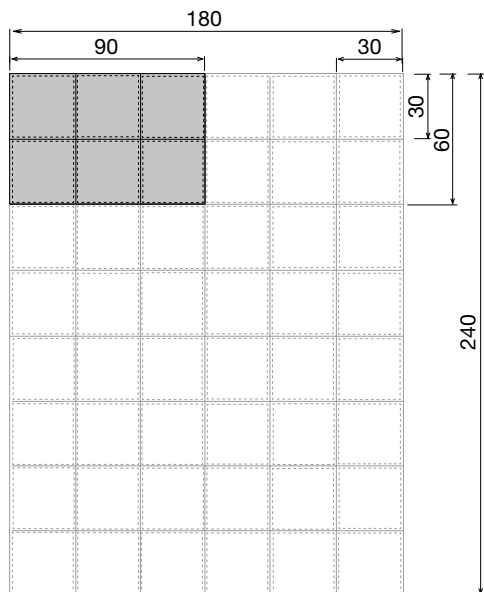

art. QUADRO / QUADRON

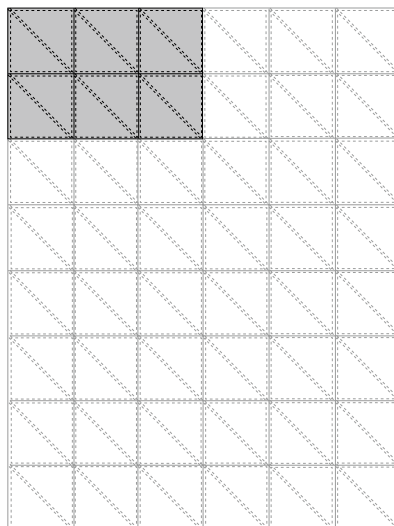

art. DIAGONALE / DIAGONALEN

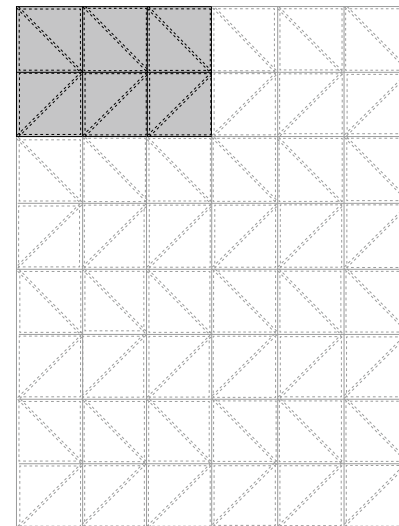

art. ZIGZAG / ZIGZAGN

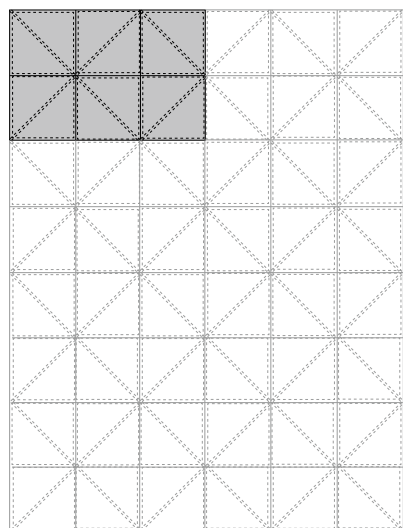

art. ROMBO / ROMBON

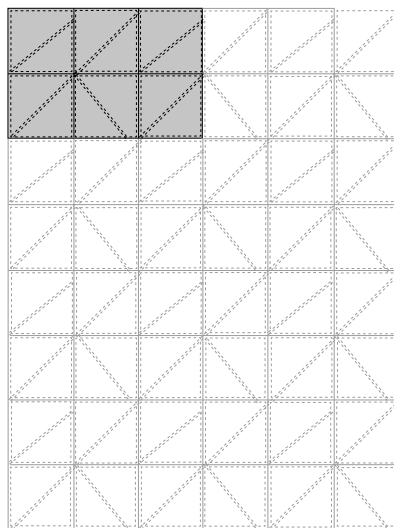

art. SEGMENTO / SEGMENTON

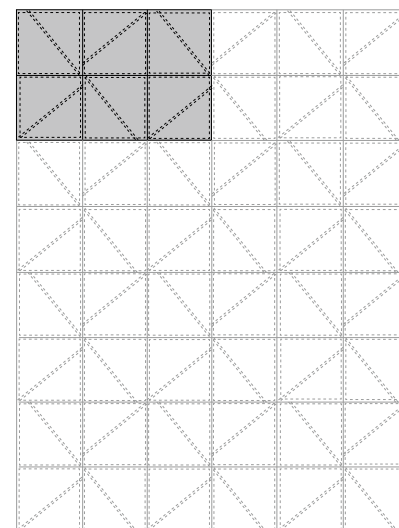

art. ROTANTE / ROTANTEN

**campionario colori - colour samples**

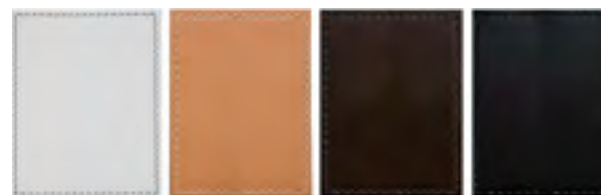

avana

naturale

testa di moro

nero

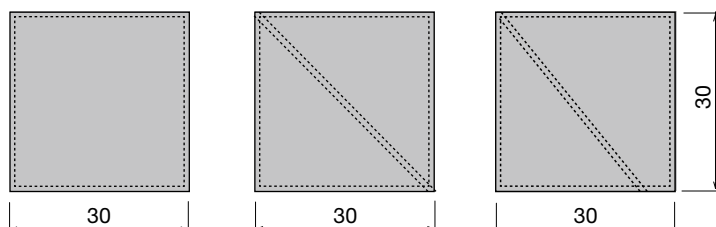

Piastrelle in cuoio rigenerato o in cuoio rigenerato montato su neoprene (**N**) componibili per formare tappeti a disegno modulare, misura minima 6 piastrelle (60 x 90 cm), massima 48 piastrelle (240 x 180 cm), in diversi colori come da nostro campionario.

*A collection of single or modular mats with a geometrical design in bonded leather or bonded leather mounted on neoprene (**N**). Min. 6 bonded leather tiles (60 x 90 cm) and Max. 48 pieces (240 x 180 cm), in various colours as per our samples.*



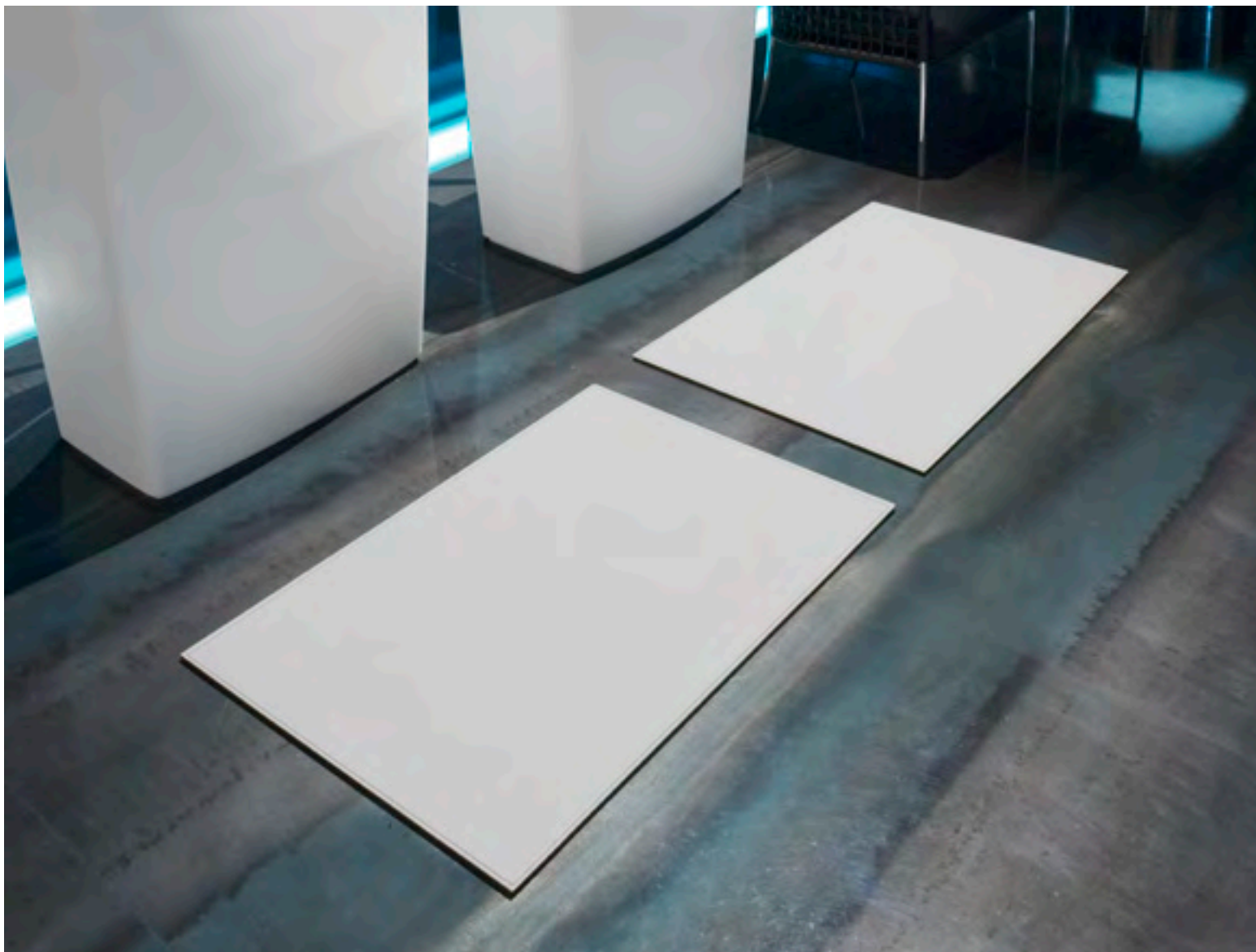

art. ELEMENTO90N

art. ELEMENTO120N

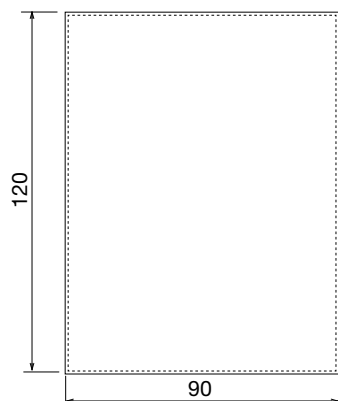
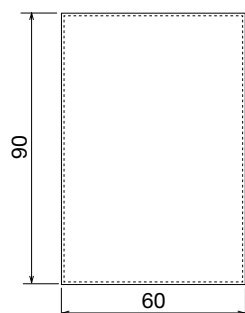

**campionario colori - colour samples**

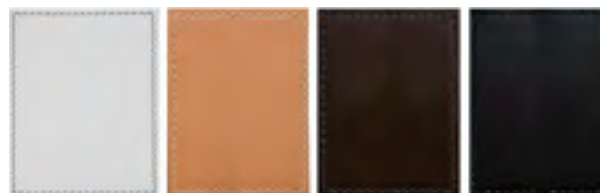

avana naturale testa di moro nero

Tappeto in cuoio rigenerato montato su neoprene, in diversi colori come da nostro campionario.

*Mat in bonded leather mounted on neoprene, in various colours as per our samples.*



art. COCCO90N

art. COCCO120N

campionario - colour samples

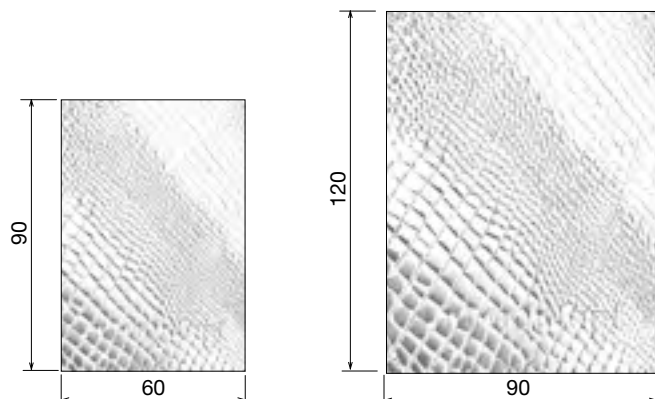

cocco moka

cocco bianco

Tappeto in cuoio rigenerato lucido con stampa coccodrillo montato su neoprene come da nostro campionario.

*Mat in bonded glossy leather crocodile pattern mounted on neoprene as per our samples.*

accessori  
accessories

**CARTELLA COLORI - LEGNO LACCATO, CRISTALLI 8 e 12 mm**

**LEGNO LACCATO**

Tutte le laccature sono in finitura opaca, gofrata o lucida.

**CRISTALLO 8 mm**

I top di spessore 8 mm vengono realizzati in **cristallo laccato** o in **cristallo laccato acidato**.

**CRISTALLO 12 mm**

I top di spessore 12 mm vengono realizzati in **cristallo laccato** o in **cristallo laccato acidato**.

**COLOUR CHART – LACQUERED WOOD, GLASS 8 AND 12 mm**

**LACQUERED WOOD**

All lacquering can be either matt, embossed or glossy.

**GLASS 8 mm**

Tops 8 mm thick can be produced in **lacquered glass** or in **lacquered acid glass**.

**GLASS 12 mm**

Tops 12 mm thick can be produced in **lacquered glass** or in **lacquered acid glass**.





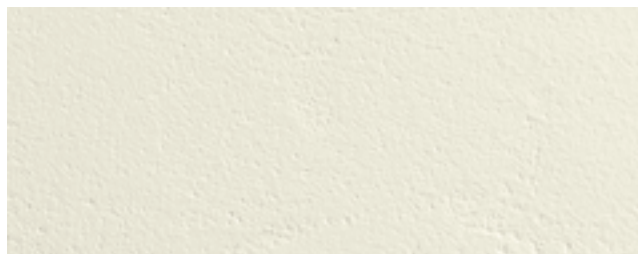

ovatta

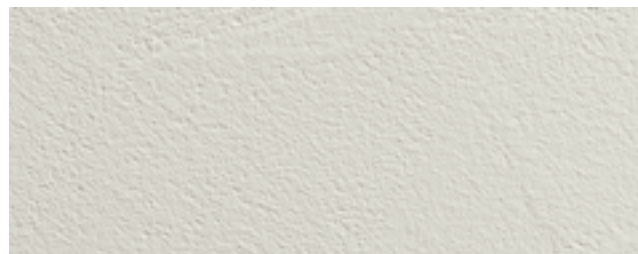

cemento

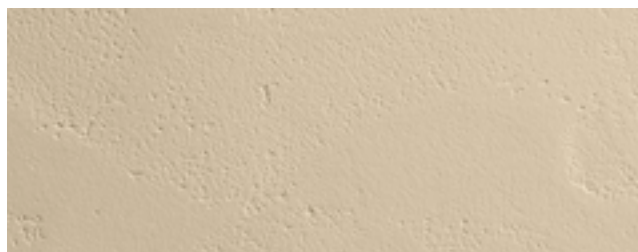

havana

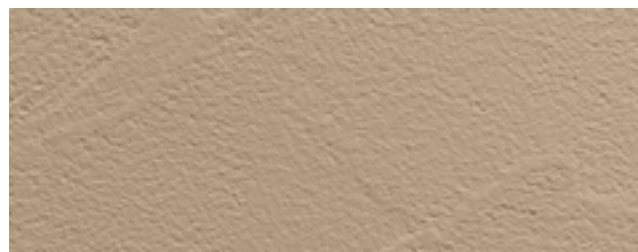

corda

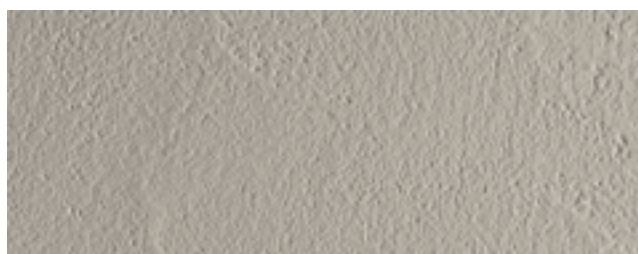

grigio smog



creta



grigio vesuvio

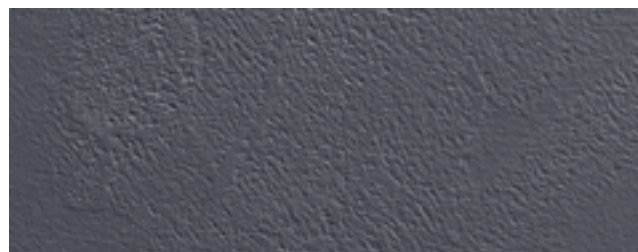

ardesia

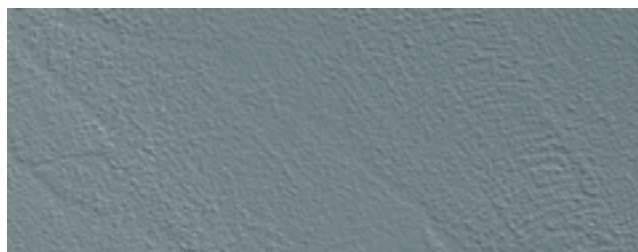

grigio fiume

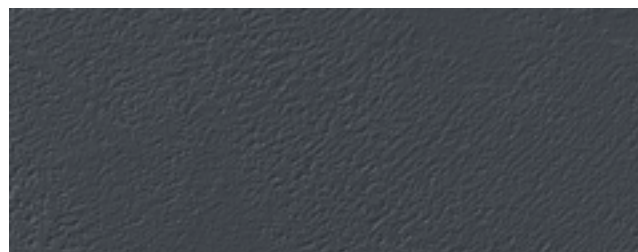

matita

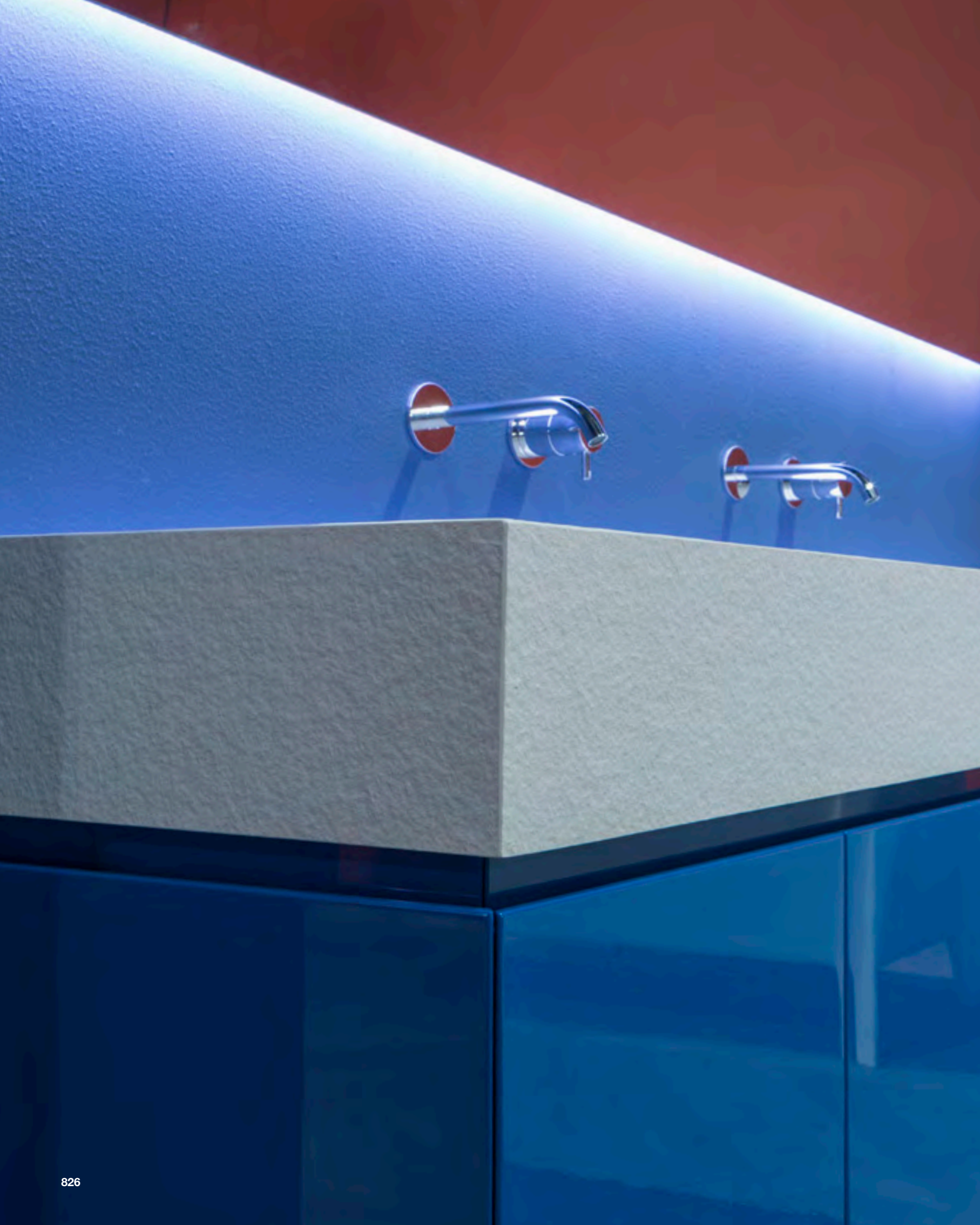



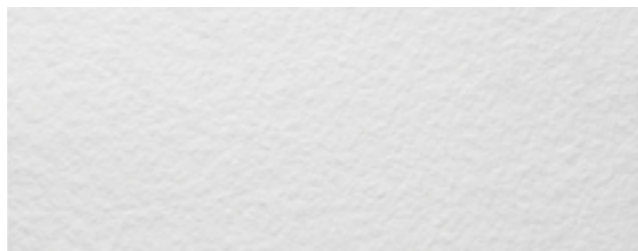

bianco

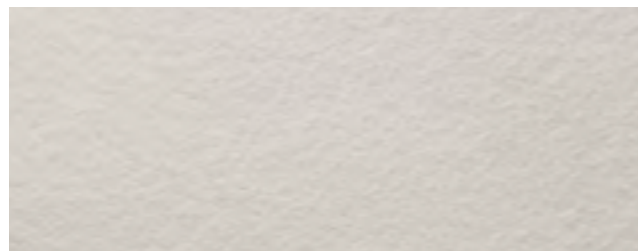

ovatta

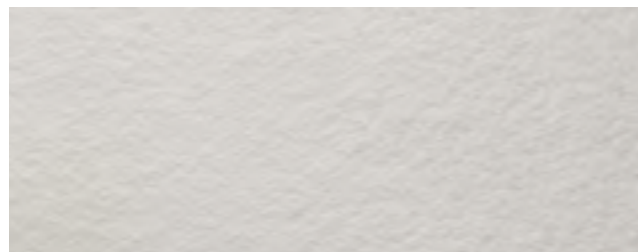

cemento

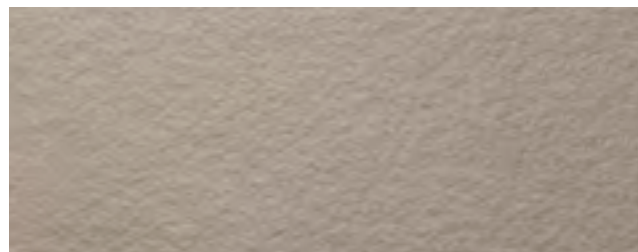

malta

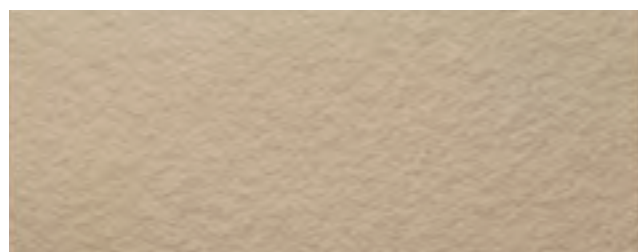

havana



corda



grigio vesuvio

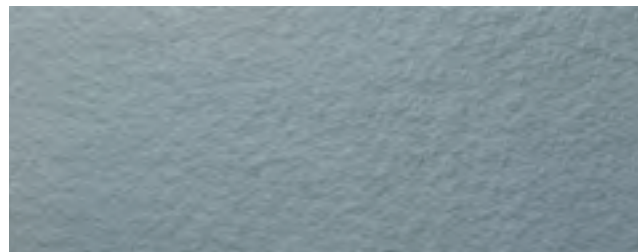

grigio fango

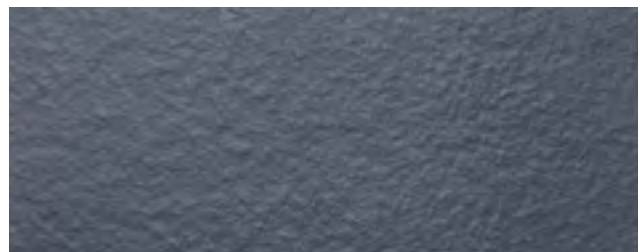

ardesia



matita



CARTELLA ESSENZE  
WOOD ESSENCE

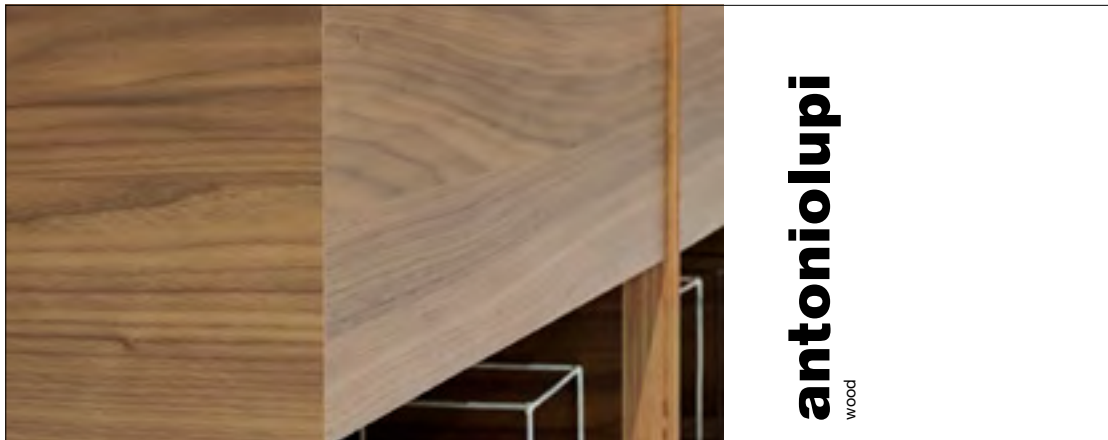

frassino moka

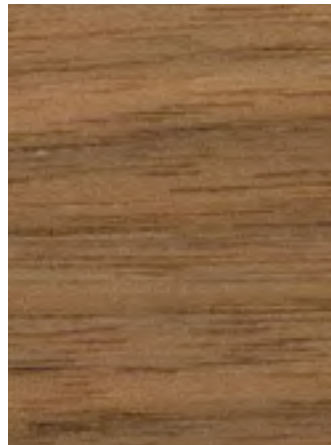

noce americano

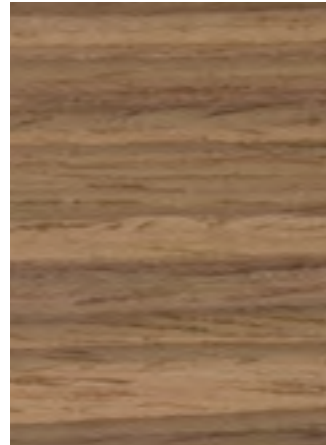

noce biondo

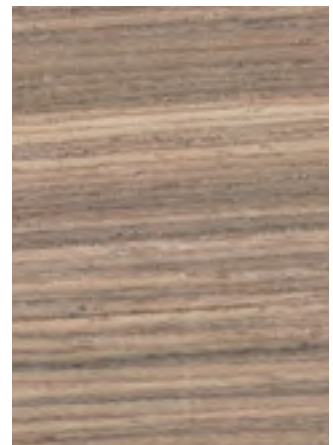

noce sbiancato

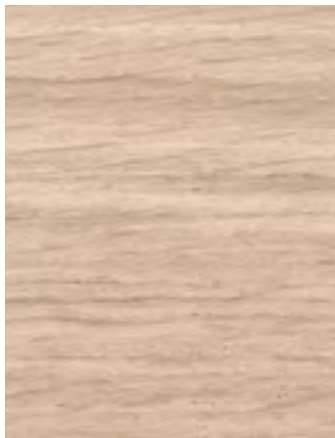

rovere sbiancato

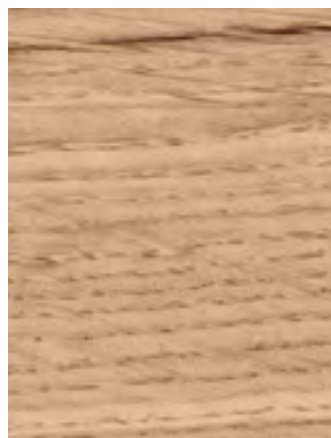

rovere naturale



rovere canapa

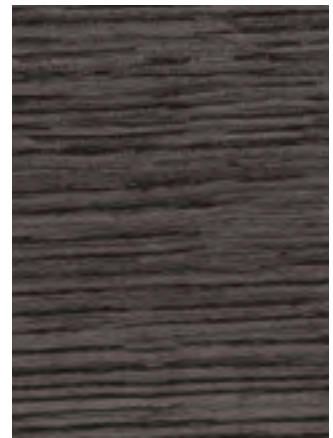

rovere grigio

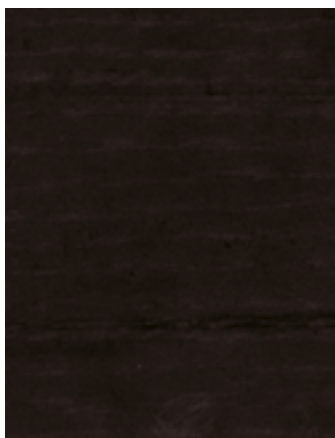

rovere wengè

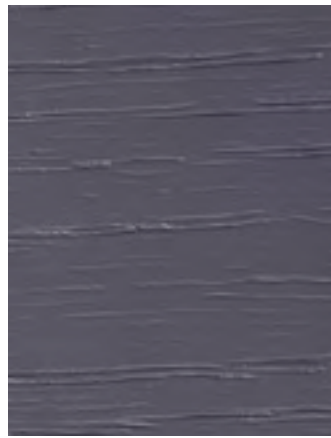

rovere provenza 779

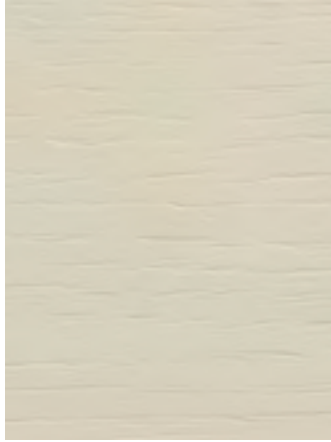

rovere ovatta 746

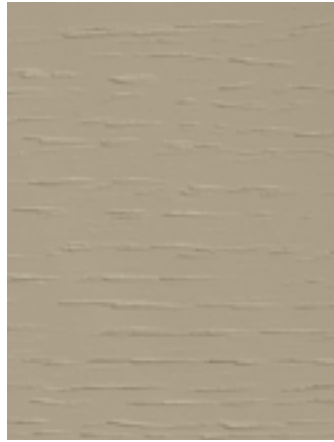

rovere havana 748

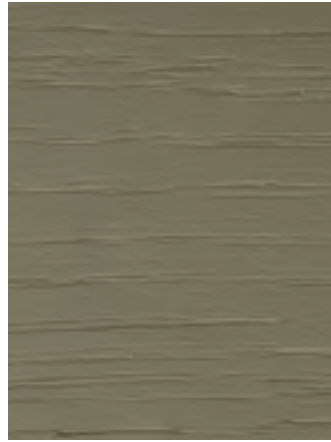

rovere savana 778



rovere biancospino 722

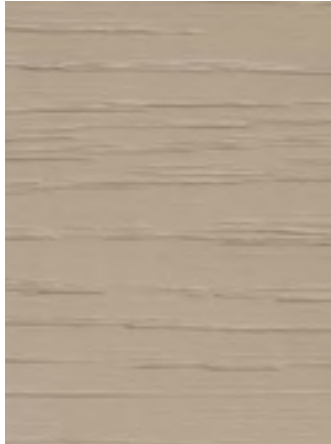

rovere deserto 782

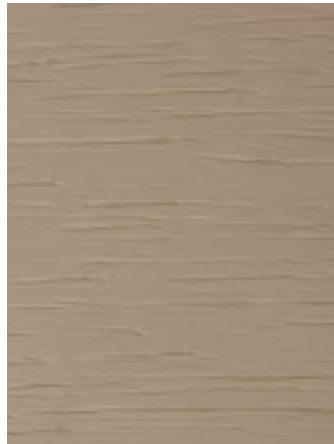

rovere corda 783

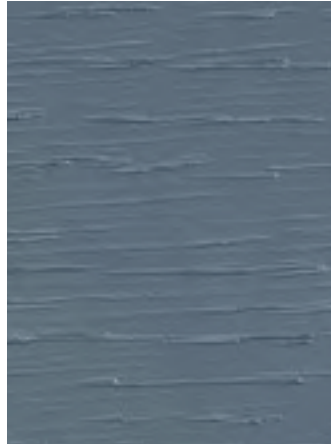

rovere periferia 780

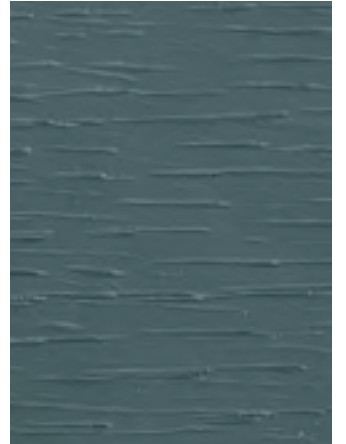

rovere fabbrica 781

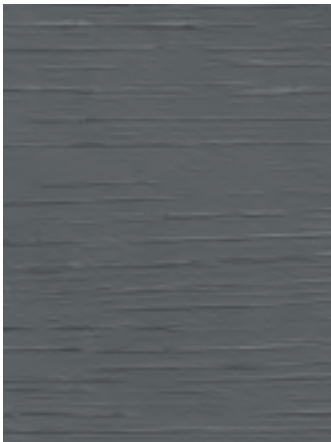

rovere talpa 784

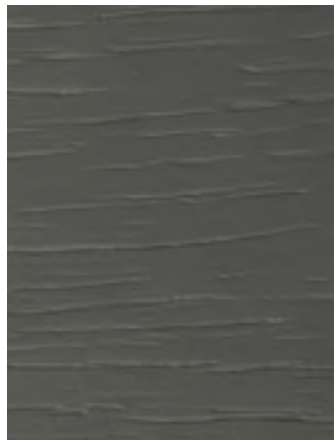

rovere creta 716



rovere grigio vesuvio 752



rovere fuliggine 754



rovere grigio smog 715



rovere eucalypto 740

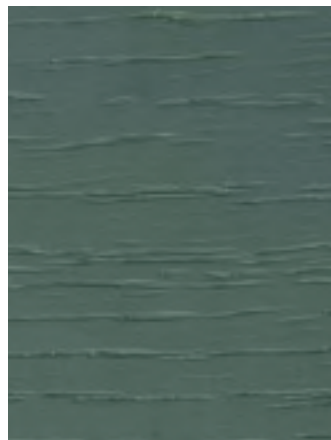

rovere vitigno 785

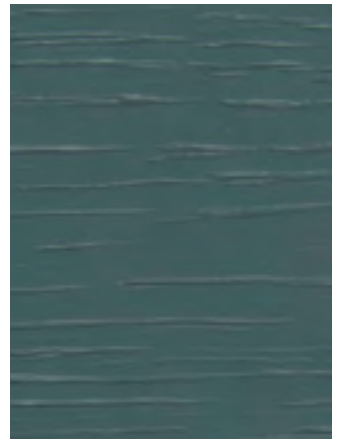

rovere stagno 786

## INFORMAZIONI ENERGETICHE

### ENERGETIC INFORMATION

#### Articoli venduti con lampade di classe energetica C e compatibili con lampade di classe energetica C e D

Articles sold with bulbs of energy class C and compatible with bulbs of energy classes C and D

LIGHT1  
LIGHT2  
LIGHT3  
RAGGIO  
RONDÓ

#### Articoli venduti con lampade di classe energetica A e compatibili con lampade di classe energetica A+ e A

Articles sold with bulbs of energy class A and compatible with bulbs of energy classes A+ and A

OBLÒ2  
OBLÒ3  
OBLÒ50  
OBLÒ150

#### Articoli muniti di lampade a led integrate di classe energetica A non sostituibili

Articles provided with integrated led bulbs of energy class A not replaceable

DAMA75L	LAMPO75L	RIGA54	RIGA216	RIGA_S1144	SPIO175W
DAMA75W	LAMPO75W	RIGA63	RIGA1108	RIGA_S1153	SPIO250W
DAMA108L	MANTRA150	RIGA72	RIGA1117	RIGA_S1162	SPIO275W
DAMA108W	MANTRA175	RIGA81	RIGA1126	RIGA_S1171	STRAPPOL
DIVO220L	MANTRA190	RIGA90	RIGA1135	RIGA_S1180	TALK50L
DIVO220W	MANTRA250	RIGA99	RIGA1144	RIGA_S1189	TALK50W
FLASH50L	MANTRA275	RIGA108	RIGA1153	RIGA_S1198	TALK75L
FLASH50W	MANTRA290	RIGA117	RIGA1162	RIGA_S1207	TALK75W
FLASH75L	METEO1	RIGA126	RIGA1171	RIGA_S1216	
FLASH75W	METEO2	RIGA135	RIGA1180	SEGRETO	
FLASH90L	METEO2C	RIGA144	RIGA1189	SFOGLIA75L	
FLASH90W	METEO3C	RIGA153	RIGA1198	SILENZIOL	
FLASH100L	METEO_RAL	RIGA154	RIGA1207	SOFFIOL	
FLASH100W	METEOXXL	RIGA162	RIGA1216	SOTTOQUADRO	
FLASH125L	NEUTROLED50W	RIGA163	RIGA_S154	SPIO1W	
FLASH125W	NEUTROLED75W	RIGA171	RIGA_S163	SPIO2W	
FLASH150L	NEUTROLED90W	RIGA172	RIGA_S172	SPIO3W	
FLASH150W	NEUTROLED100W	RIGA180	RIGA_S181	SPIO4W	
FUORIMETEO10	NEUTROLED110W	RIGA181	RIGA_S190	SPIO5W	
FUORIMETEO20	OVIDIO50L	RIGA189	RIGA_S199	SPIO50W	
FUORIMETEO20C	OVIDIO50W	RIGA190	RIGA_S1108	SPIO75W	
FUORISTRAPPOL	OVIDIO75L	RIGA198	RIGA_S1117	SPIO150L	
LAMPO50L	OVIDIO75W	RIGA199	RIGA_S1126	SPIO150W	
LAMPO50W	PERIPLO	RIGA207	RIGA_S1135	SPIO175L	

#### Articoli venduti con lampade di classe energetica A e compatibili con lampade di classe energetica A++, A+ e A

Articles sold with bulbs of energy class A and compatible with bulbs of energy classes A++, A+ and A

CURVA\_UP  
CURVA\_DOWN







Prodotto interamente in Italia.  
*Entirely made in Italy.*

© Antonio Lupi Design S.p.A. 2015

**NOTA:** alla Antonio Lupi Design S.p.A. è riservata la facoltà di apportare ai propri modelli qualsiasi modifica estetica, tecnica, nelle dimensioni e nei colori, ritenuta necessaria, nonché la facoltà di sospendere la produzione in qualunque momento senza preavviso, rinunziata fin d'ora da parte del committente ogni conseguente richiesta risarcitoria. Si declina ogni responsabilità relativa ad eventuali inesattezze contenute in questo depliant, se dovute ad errori di stampa o trascrizioni.

**NOTE:** Antonio Lupi Design S.p.A. reserves the right to make any and all necessary esthetic, technical, colour or size modifications in order to enhance use and esthetic value, and may suspend the production cycle at any moment without notice. Such instances may not be subject to claim by the client. We decline all responsibilities for any possible uncertainties due to misprints in this brochure.









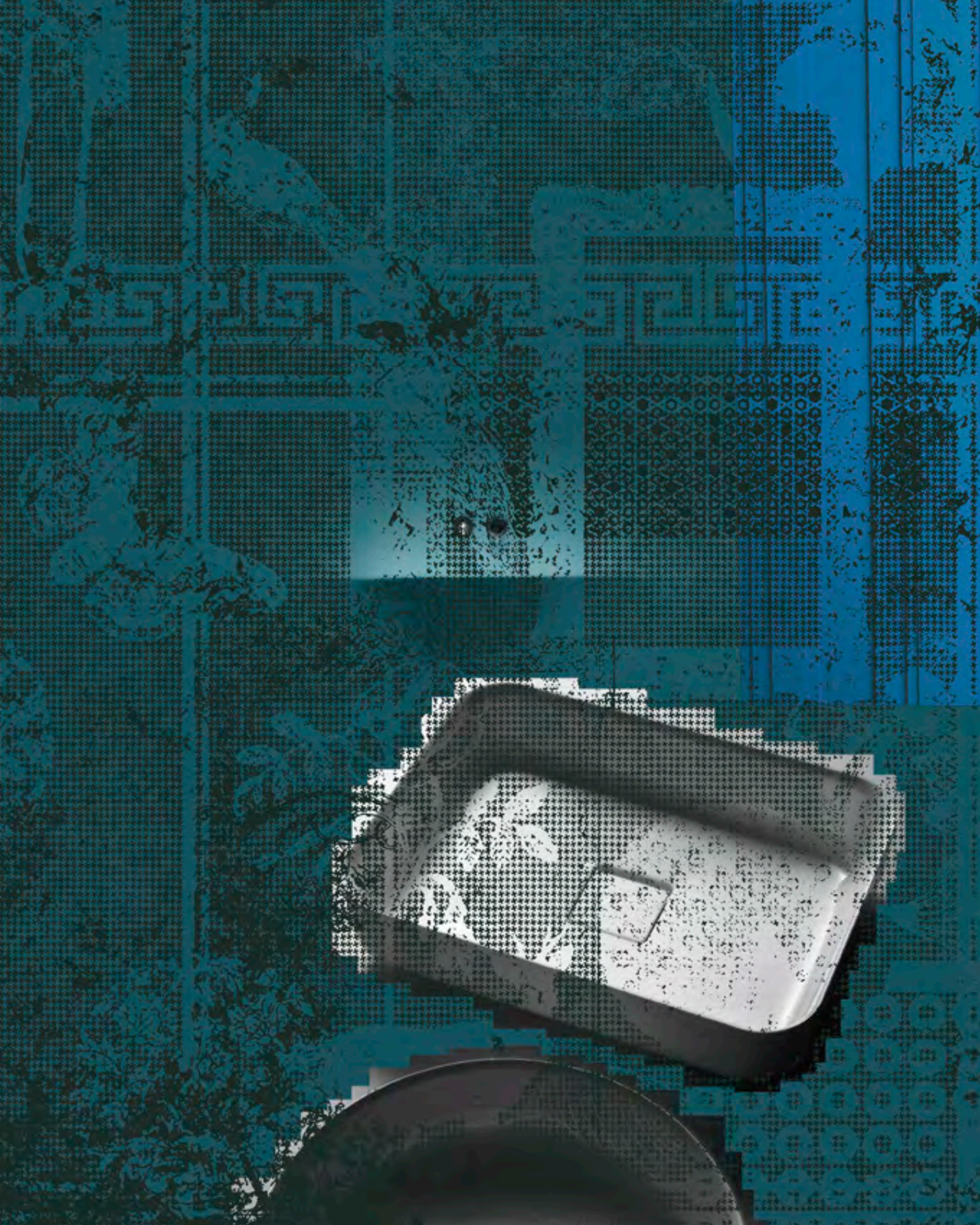



**antoniolupi**

**73**

VIA MAZZINI

**75**

Antonio Lupi Design S.p.A.  
via Mazzini 73/75 - 50050 Stabbia  
Cerreto Guidi (Firenze) - Italy  
T +39 0571 586881\_95651  
F +39 0571 586885  
[www.antoniolupi.it](http://www.antoniolupi.it)  
[lupi@antoniolupi.it](mailto:lupi@antoniolupi.it)